



**B.M.S. COLLEGE OF ENGINEERING
BANGALORE – 019**



(AUTONOMOUS INSTITUTE, AFFILIATED TO VTU)

DEPARTMENT OF MECHANICAL ENGINEERING

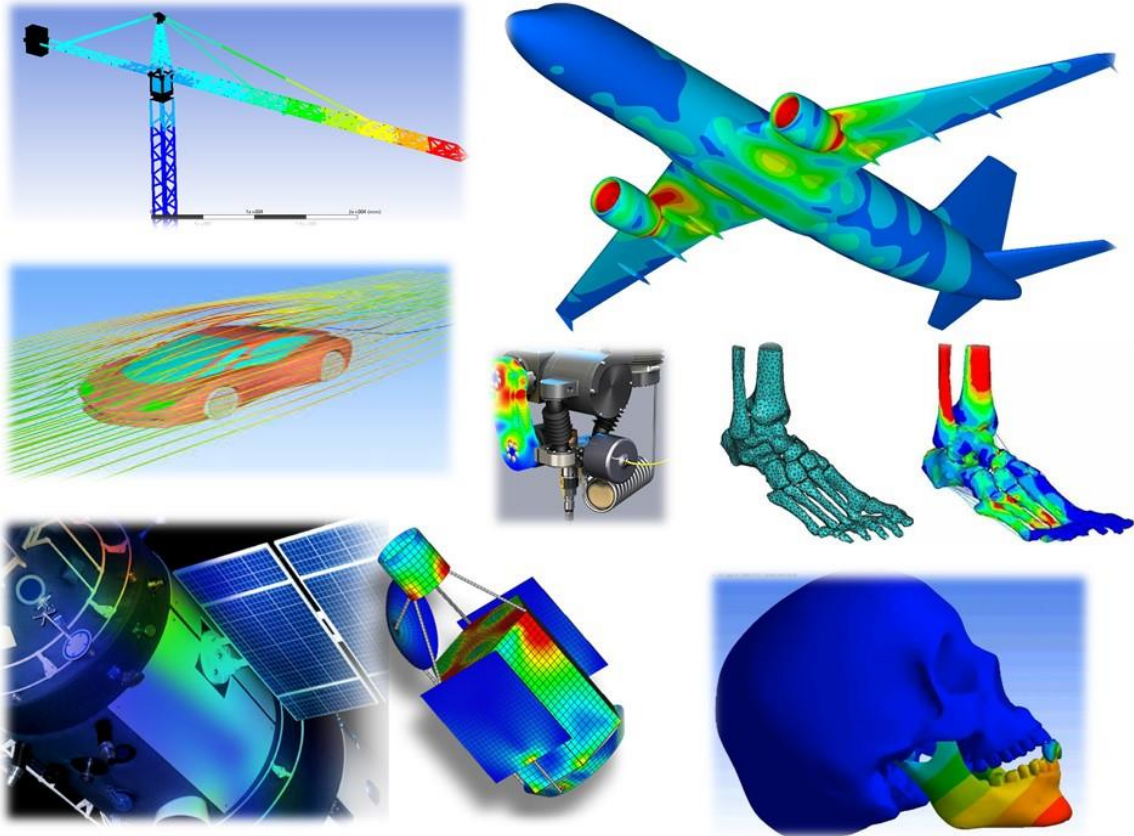

**MODELING AND FINITE ELEMENT
ANALYSIS - LABORATORY (16ME6DCMFE)**

Laboratory for 6th Semester Mechanical Engineering

Student Name :	USN:
Section: Batch:	Staff in charge:

VISION

To become a centre of excellence in educating students to become successful Mechanical Engineers

MISSION

- To empower the students with fundamentals for successful career in the field of Mechanical Engineering
- To continue their education through post-graduation, research & development
- To provide service to the society

COURSE OUT COME

CO1	APPLY basics of Theory of Elasticity to continuum problems.
CO2	FORMULATE finite elements like bar, truss and beam elements for linear static structural analysis.
CO3	FORMULATE 2D and axisymmetric finite elements.
CO4	Develop finite element equations for 1D heat transfer elements and solve numericals.
CO5	Apply finite element simulation tool to solve practical problems (Lab and Self-study).

**B.M.S. COLLEGE OF ENGINEERING,
BANGALORE – 19**

(AUTONOMOUS INSTITUTE, AFFILIATED TO VTU)

CERTIFICATE

This is to certify that Mr. /Miss. _____

With USN _____, a student of VI Semester B.E. (Mech.), B.M.S. College of Engineering, has successfully completed the lab work connected with MODELING AND FINITE ELEMENT ANALYSIS (16ME6DCMFE) Laboratory as prescribed by the AUTONOMOUS INSTITUTION UNDER VTU during the year 2018-19.

Total Marks Obtained

15

Staff In-charge:
Date :

Head of the department
Mechanical Engineering

MODELING AND FINITE ELEMENT ANALYSIS Lab [16ME6DCMFE]

No. of Practical Hrs/ Week: 02

PART-A

Study of a FEA package and analysis of;

- a) Trusses
- b) Bars of constant cross section area, tapered cross section area and stepped bar.
- c) Beams -Simply supported, cantilever, beams with UDL, and beams with varying load etc.

PART-B

- d) Stress analysis of a rectangular plate with a circular hole, axisymmetric problems.
- e) Dynamic Analysis
 - 1) Fixed -fixed beam for natural frequency determination
 - 2) Bar subjected to forcing function
 - 3) Fixed -fixed beam subjected to forcing function

PART-C [SELF-STUDY]

- a) Thermal Analysis -2D problem with conduction and convection boundary conditions
- b) Fluid flow Analysis -Potential distribution in the 2 -D bodies

REFERENCE BOOKS:

1. **ANSYS Workbench Tutorial Release 14**, Structural and Thermal Analysis Using Ansys Mechanical APDL Release 14 Environment, Kent Lawrence, Schroff Development Corporation, Website: www.SDCpublications.com
2. **Practical Finite Element Analysis**, Nitin S. Gokhale, Sanjay S. Deshpande, Dr. Anand N. Thite, Finite To Infinite, ISBN 978-81-906195-0-9, E-mail: finite@vsnl.com, Website: www.finitetoinfinite.com
3. **FINITE ELEMENT ANALYSIS USING ANSYS®**, SrinivasPaleti, Sambana, Krishna Chaitanya, Datti, Rajesh Kumar, PHI Publication, ISBN: 978-81-203-4108-1

WEB REFERENCE:

1. www.ansys.com
2. www.mece.ualberta.ca/tutorials/ansys
3. <http://mae.uta.edu/~lawrence/>
4. <http://expertfea.com/tutorials.html>

Online course:

1. 'A Hands-on Introduction to Engineering Simulations' by Cornell University. Learn how to analyze real-world engineering problems using ANSYS simulation software and gain important professional skills sought by employers.

<https://www.edx.org/course/hands-introduction-engineering-cornellx-engr2000x-0>

2. <https://www.diyguru.org/course/ansys-fea-fem-online-certification-course/>
3. <https://www.edx.org/course/you-xian-yuan-fen-xi-yu-ying-yong-finite-tsinghuax-70120073x>
4. <https://www.nafems.org/e-learning/schedule/>
5. <http://www.icaeec.com/index.php/courses/introduction-to-fem/introduction-to-fem-analysis-with-patran-msc-nastran>

Scheme for evaluation:

One Question from Part A	10Marks
One Question from Part B	10Marks
Record and Viva-Voce	10 Marks
Total	30 Marks

B.M.S. COLLEGE OF ENGINEERING, BANGALORE – 19
(AUTONOMOUS INSTITUTE, AFFILIATED TO VTU)

MODELLING AND FINITE ELEMENT ANALYSIS Lab
LESSON PLAN

Week	Class	Topic to be covered	Page No.	Date
PART A				
1	1	Study of FEA package. Modeling and stress analysis of Trusses		
2	2	Analysis of trusses continued		
3	3	Bars of constant cross section area, tapered cross section area and stepped bars		
4	4	Analysis of bars continued		
5	5	Beams: Cantilever, Simply supported, overhanging beams with self-weight, Concentrated loads, UDL, Direct moment and UVL with different support conditions.		
6	6	Analysis of beams continued		
7	7	CIE-1 for 20 Marks		
PART B				
8	8	Stress analysis of rectangular plate with circular hole		
9	9	Stress analysis of Axisymmetric problems – Pressurized cylinder and rotating disc or cylinders(Solid and hollow)		
10	10	Dynamic Analysis: Modal analysis of Bars and Beams		
11	11	Dynamic Analysis: Harmonic analysis of Bar subjected to forcing function and Fixed-Fixed beam subjected to forcing function		
12	12	CIE-2 for 20 Marks		
PART C [Material for self study]				
13	13	Thermal Analysis – 1D problems with conduction and convection boundary conditions		
14	14	Thermal Analysis – 2D problems with conduction and convection boundary conditions		
15	15	Fluid flow Analysis – Potential distribution in 2-D bodies		

Chapter1: Introduction to Finite Element Analysis

1.1 What is FEA?

Finite Element Analysis is a way to simulate loading conditions on a design and determine the design's response to those conditions.

The design is modeled using discrete building blocks called **elements**. Each element has exact equations that describe how it responds to a certain load. The "sum" of the response of all elements in the model gives the total response of the design. The elements have a finite number of unknowns, hence the name **finite elements**.

The **finite element model**, which has a *finite* number of unknowns, can only *approximate* the response of the physical system, which has *infinite* unknowns.

So the question arises: *How good is the approximation?*

Unfortunately, there is no easy answer to this question. It depends entirely on what you are simulating and the tools you use for the simulation. We will, however, attempt to give you guidelines throughout this training course.

Physical System

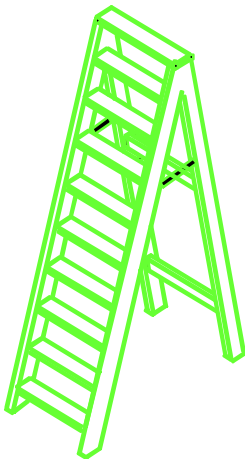

F.E. Model

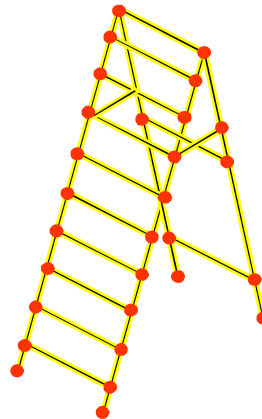

Most often the mathematical models result in algebraic, differential or integral equations or combinations thereof. Seldom these equations can be solved in closed form (Exact form), and hence numerical methods are used to obtain solutions. Finite difference method is a classical method that provides approximate solutions to differential equations with reasonable engineering accuracy. There are other methods of solving mathematical equations that are taught in traditional numerical methods courses. Finite Element Method is one of the numerical methods of solving differential equations. The FEM originated in the area of structural mechanics, and has been extended to other areas of solid mechanics and later to other fields such as heat transfer, fluid dynamics and electromagnetic devices. In fact FEM has been recognized as a powerful tool for solving partial differential equations and integral-differential equations. And in the near future it may become the numerical method of choice in many engineering and applied science areas. One of the reasons for Fem.'s popularity is that the method results in computer programs versatile in nature that can be used to solve many practical problems with least amount of training. Obviously there is a

danger in using computer programs without proper understanding of the theory behind them, and that is one of the reactions to have a thorough understanding of the theory behind the Finite Element Method.

1.2 Brief History of the FEM

Academic and industrial researchers created the finite element method of structural analysis during the 1950s and 1960s. The underlying theory is over 100 years old, and was the basis for pen-and-paper calculations in the evaluation of suspension bridges and steam boilers.

1. 1943 Courant (Variational Methods)
2. 1960 Clough ("Finite Element", plane problems)
3. 1970 Applications on mainframe computers
4. 1980 Microcomputers, pre- and postprocessors
5. 1990 Analysis of large structural systems
6. 1996 Partition of unity method (PUM) Melenk and Babuska
7. 1996 h-p Cloud Method of Duarte and Oden
8. 1996 Meshless methods by Belytschko et.al

1.3 Why is FEA needed?

- To reduce the amount of prototype testing – Computer simulation allows multiple “what-if” scenarios to be tested quickly and effectively.
- To simulate designs that are not suitable for prototype testing – Example: Surgical implants, such as an artificial knee.
- The bottom line:
 - Cost savings
 - Time savings... reduce time to market!
 - Create more reliable, better-quality designs

FEM TO DESIGNERS:

- Easily applied to complex, irregular shaped objects composed of several different materials and having complex boundary conditions.
- Applied to steady state time dependent, Eigen Value problems.
- Applicable to linear and non-linear problems.
- Number of general-purpose FEM packages are available.
- FEM can be coupled to CAD programs to facilitate Solid modeling and mesh generations.
- Many FEM software packages feature GUI interfaces, automeshers and sophisticated post processors and graphics to speed the analysis and makes Pre and post processing more user friendly.

FEM TO DESIGN ORGANISATION:

- Reduced Testing and Redesign costs thereby shortening of product development cycle.
- Identify issues in designs before tooling is committed.
- Refine components before dependencies to other components prohibit change.
- Optimize performance before prototyping.
- Discovers design problems before litigations.
- Allows more time for designers to use engineering judgment and less time for further thinking.

1.4 INTRODUCTION TO STRUCTURAL ANALYSIS

Structural Analysis involves determining the stresses and strains in a structure, when subjected to a variety of loading conditions, under static or dynamic conditions. The term structural (or structure) implies not only naval, aeronautical and mechanical structures such as ship hulls, aircraft bodies and machine housings, as well as mechanical components such as pistons, machine parts, and tools but also civil engineering structures such as bridges and buildings.

The primary unknowns (nodal degrees of freedom) calculated in a structural analysis are displacements. Other quantities, such as strains, stresses, and reaction forces are then derived from the nodal displacement

The large size problems handled by modern digital computers connected with static and dynamic analysis of complicated structures are generally of the form

$$[M]\{\ddot{u}\} + [C]\{\dot{u}\} + [K]\{u\} = \{F(t)\}$$

Where [M] is the global mass matrix, [C] the global damping matrix and [K] the global stiffness matrix. {F(t)} is a given forcing function vector in time, { \ddot{u} } is the resultant acceleration vector, { \dot{u} } and {u} represent its velocity and displacement vectors respectively. Generally, [M], [C] and [K] are banded. Depending upon the nature of these coefficients, the problems are classified as static, dynamic, linear and non-linear. The following are some of the specific classifications:

- When [C] = 0, [M] = 0, [K] and {F (t)} are constants, the result is a **static linear problem**.
- When [M] and [C] are absent, and [K] is a function of {u} and {F (t)} a constant the result is a **non-linear static problem**.
- If {F (t)} and [C] are absent, and [M] and [K] are constants, it is an **Eigen value problem**.
- If [M], [C] and [K] are constants and {F(t)} is a periodic forcing function, the result is a multi-degree of freedom **steady state vibration problem**
- If [M], [C] and [K] are constants and {F(t)} is a function of time, the result is a **transient vibration problem**.

Static structural Analysis - Used to determine displacements, stresses, etc. under static loading conditions which includes both linear and nonlinear characteristics. Nonlinearities can include plasticity, stress stiffening, large deflection, large strain, hyper-elasticity, contact surfaces, and creep.

External excitations as well as the response of the system are time invariant. Inertial forces and dissipative forces are neglected. If the highest frequency component of excitation is less than about one-third the lowest fundamental frequency of the system, a static analysis is usually assumed to be sufficient.

In different domain statics problem are of the type; $[K]\{u\} = F$

Where [K] represents Property, {u} Behavior and {F} Action.

	Property [K]	Behavior {u}	Action {F}
Elastic	Stiffness	Displacement	Force
Thermal	Conductivity	Temperature	Heat Source
Fluid	Viscosity	Velocity	Body Force
Electrostatic	Dielectric permittivity	Electric Potential	Charge

Dynamic Analysis

In dynamic analysis, external excitation and the response are time dependent. The different types of dynamic are:

Modal Analysis - Used to calculate the natural frequencies and mode shapes of a structure. Different mode extraction methods are available.

Transient Dynamic Analysis - Used to determine the response of a structure to arbitrarily time-varying loads. All nonlinearities mentioned under Static Analysis are allowed.

Harmonic Analysis - Used to determine the response of a structure to harmonically time-varying loads.

Spectrum Analysis - An extension of the modal analysis, used to calculate stresses and strains due to a response spectrum or a PSD input (random vibrations).

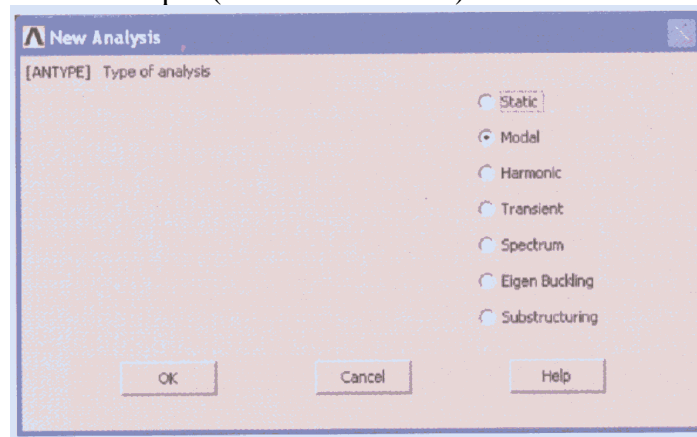

1.5 The Finite Element (FE) Approach

In this approach, the entire solution domain is divided into small finite segments (hence the name 'finites elements'). Over each element, the behavior is described by the differential governing equations. All these small elements are assembled together and the requirements of continuity and equilibrium are satisfied between neighboring elements. Provided that the boundary conditions of the actual problem are satisfied, a unique solution can be obtained to the overall system of linear algebraic equations (with a sparsely populated solution matrix).

The FE method is very suitable for practical engineering problem of complex geometries. To obtain good accuracy in regions of rapidly changing variables, a large number of finite elements must be used.

1.6 Steps in FEM- Linear Static Structural Analysis

Step1: Discretisation of the Structure

The first step in the finite Element method is to divide the structure or solution region into subdivisions or elements. Hence the structure is to be modeled with suitable finite elements. The number, type, size and arrangement of the elements are to be decided. These elements can be 1-D, 2-D, 3-D or axis symmetric.

Step 2: Selection of a proper interpolation or displacement model

Since the displacement solution of a complex structure under any specified load conditions cannot be predicted exactly, we assume some suitable solution within an element to approximate the unknown solution. The assumed solution must be simple from a computational point of view, but it should satisfy certain convergence

requirements. In general, the solution or the interpolation model is taken in the form of a polynomial.

(I.e. define the behavior of variables in each element by suitable shape function. Choose the displacement at each nodal point as the unknown variable and use the shape functions to describe how the geometry and variables change across each element. For example; linear or quadratic. Higher the order of the shape function, more nodal points are assigned to the element. Accuracy of the solutions can be improved either by using large number of simple elements – H convergence or increasing the order of the shape functions - P convergence).

Step 3: Element strains and stresses

From the displacements, derive the strains and stresses within each element by using the strain-displacement relationship and Hooke's law (constitutive equations). Compatibility equations are automatically satisfied within each element because the displacements are chosen as the unknown variables.

Step 4: Derivation of element stiffness matrices and load

From the assumed displacement model, the stiffness matrix $[K^{(e)}]$ and the load vector $F^{(e)}$ of element "e" are to be derived by using equilibrium conditions or a suitable variational principle.

Step 5: Assembly of elemental equations to obtain the overall equilibrium equations

Since the structure is composed of several finite elements, the individual element stiffness matrices and load vectors are to be assembled in a suitable manner and the overall equilibrium equation can be formulated as

$$[K]\{Q\} = \{F\}$$

Where $[K]$ is called the assembled stiffness matrix, $\{Q\}$ is the vector of nodal displacement and $\{F\}$ is the vector of nodal forces for the complete structure. Since the summation of stiffness is carried out only on elements sharing a particular node, the overall stiffness matrix will be sparsely populated. The assembled stiffness matrix is singular. The process of finding the appropriate location for the individual element matrix in the Global matrix is called Direct Stiffness Method.

Step 6: Imposition of the Boundary conditions.

These can take the form of prescribed displacement, sliding against a rigid surface, attached spring, prescribed forces/stresses or pressures. More complex boundary conditions occur in contact problems. The constraints can be single point constraint or multipoint constraint. These constraints can be handled by elimination or Penalty approach.

Step 7: Solution for the unknown nodal displacements

After the incorporation of the boundary conditions, the equilibrium equations can be expressed as

$$[K]\{Q\} = \{F\}$$

The modified stiffness matrix is non-singular. For linear problems, the vector $\{Q\}$ can be solved very easily using techniques such as Gauss Elimination method. But for nonlinear problems, the solution has to be obtained in a sequence of steps, each step involving the modification of the stiffness matrix $[K]$ and /or the load vector $\{F\}$.

Step 8: Computation of element strains and stress

From the known nodal displacements $\{Q\}$, if required, the element strains and stresses can be computed by using the necessary equations of solid or structural mechanics. Also the reactions can be computed.

The terminology used in the above steps has to be modified if we want to extend the concept to other fields. For example, we have to use the term continuum or domain in the place of structure, field variable in place of displacement, characteristic matrix in place of stiffness matrix, and element resultants in place of element strains.

In general, a finite element solution may be broken into the following three stages. This is a general guideline that can be used for setting up any finite element analysis:

1. **Preprocessing: defining the problem**; the major steps in preprocessing are given below:
 - Define keypoints/lines/areas/volumes (Or Building a solid model)
 - Define element type and material/geometric properties
 - Mesh lines/areas/volumes as requiredThe amount of detail required will depend on the dimensionality of the analysis (i.e. 1D, 2D, axi-symmetric, 3D).
2. **Solution: assigning loads, constraints and solving**; here we specify the loads (point or pressure), constraints (translational and rotational) and finally solve the resulting set of equations.
3. **Postprocessing: further processing and viewing of the results**; in this stage one may wish to see:
 - Lists of nodal displacements
 - Element forces and moments
 - Deflection plots
 - Stress contour diagrams

1.7 ADVANTAGES OF FEM:

- Can readily handle complex geometry
- Can handle complex analysis types
 - Vibration
 - Transients
 - Nonlinear
 - Heat Transfer
 - Fluids
- Can handle complex loading
 - Node-Based loading (Point Loads)
 - Element-based loading (Pressure, thermal, inertial forces)
 - Time or frequency dependent loading
- Can handle complex restraints
 - Indeterminate_structures can be analyzed
- Can handle bodies comprised of non homogeneous materials
 - Every element in the model could be assigned a different set of material properties
- Can handle bodies comprised of nonisotropic materials
 - Orthotropic
 - Anisotropic
- Special material effects are handled
 - Temperature dependent properties

- Plasticity
- Creep
- Swelling
- Special geometric effects can be modeled
 - Large displacements
 - Large Rotations

1.8 DISADVANTAGES OF FEM:

- A specific numerical result is obtained for a specific problem. A general closed form solution, which would permit one to examine system response to changes in various parameters.
- The FEM is applied to an approximation of the mathematical model of a system (The source of so called inherited errors.)
- Experience and judgment are needed in order to construct a good finite element model.
- Numerical Problems
 - Computers only carry a finite number of significant digits.
 - Round off and error accumulation
 - Can help the situation by not attaching stiff (small) elements to flexible (large) elements
- Susceptible to user introduced modeling errors
 - Poor choice of element types
 - Distorted elements
 - Geometry not adequately modeled
- Certain effects not automatically included
 - Buckling
 - Large deflections and rotations
 - Material nonlinearities

1.9 LIMITATIONS OF FEM:

- High Speed computers and larger memory requirements.
- Obtaining material properties other than isotropic is very difficult.
- Incapable of handling incompressible fluids.
- Proper interpretation of results is more important as large output data is available.
- Larger unwanted data.
- Selection of proper mesh size is difficult.

FEM ERRORS:

Errors in FEM analysis can come at any of the following stages of the process:

- Error during conversion of mathematical model to solid model
- Descretization error
- Solution error

1.10 Commercial FEM PACKAGES:

ABAQUS(tm), ADAMS/FEA(tm), ADINA(tm), AFEMS(tm) ALGOR(tm), ANSYS(R), ANSA, AUTODYN(tm), C-MOLD(R) software CAMRAD II(R), CESAR-LCPC, NISA, IDEAS Simulation module, Pro-MECHANICA, MSC NASTRAN, MSC MARC, LS DYNA, HYPERWORKS/OPTISTRUCT, ADINA, SOLIDWORKS, 3D EXPERIENCE SIMULIA etc.

Chapter2: INTRODUCTION TO ANSYS

ANSYS is a general-purpose finite element-modeling package for numerically solving a wide variety of mechanical problems. These problems include: static/dynamic structural analysis (both linear and non-linear), heat transfer and fluid problems, as well as acoustic and electro-magnetic problems.

2.1 Why Ansys?

- ANSYS is a complete FEA software package used by engineers worldwide in virtually all fields of engineering:
 - Structural
 - Thermal
 - Fluid (CFD, Acoustics, and other fluid analyses)
 - Low- and High-Frequency Electromagnetics
- A partial list of industries in which ANSYS is used:
 - Aerospace--- Electronics & Appliances
 - Automotive--- Heavy Equipment & Machinery
 - Biomedical--- MEMS - Micro Electromechanical Systems
 - Bridges & Buildings--- Sporting Goods
- ANSYS Multiphysics is the flagship ANSYS product which includes all capabilities in all engineering disciplines.
 - *ANSYS Classic Environment* for exposure to all ANSYS functionality

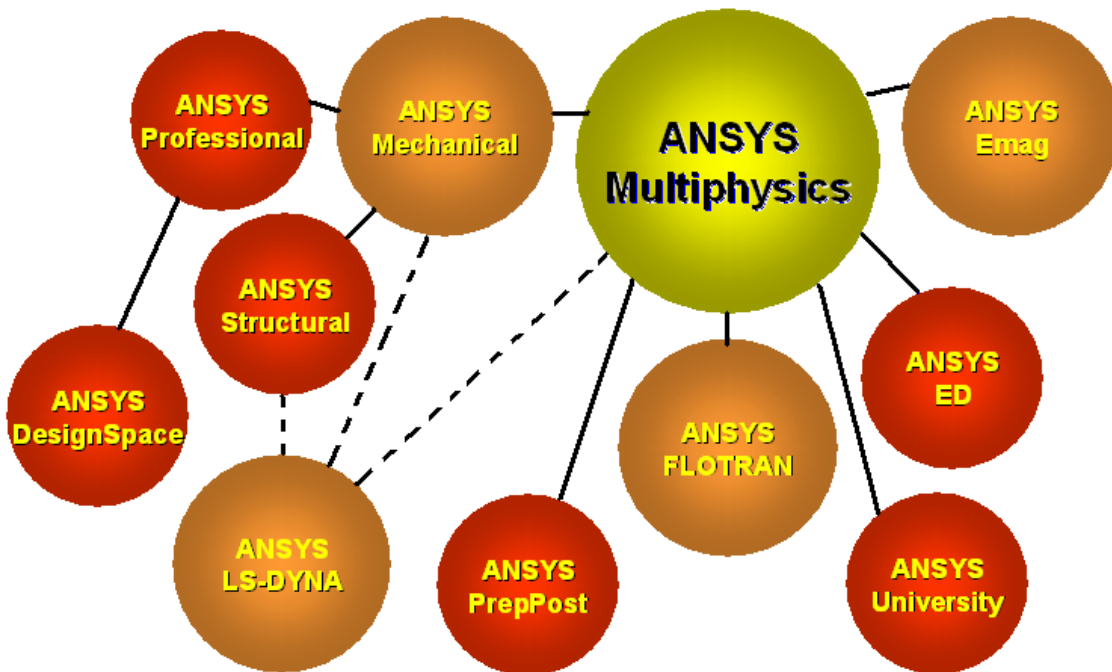

- There are three main component products derived from ANSYS Multiphysics:
 - ANSYS Mechanical – structural & thermal capabilities
 - ANSYS Emag – electromagnetics
 - ANSYS FLOTRAN – CFD capabilities

- Other product lines:
 - ANSYS LS-DYNA – for highly nonlinear structural problems
 - ANSYS Professional – linear structural and thermal analyses, a subset of ANSYS Mechanical capabilities

ANSYS Design Space – linear structural and steady state thermal analyses, a subset of ANSYS Mechanical capabilities in the Workbench Environment.

- **Structural analysis:** is used to determine deformations, strains, stresses, and Reaction forces.
- **Static analysis:**
 - Used for static loading conditions.
 - Nonlinear behavior such as large deflections, large strain, contact, plasticity, hyper elasticity, and creep can be simulated.
- **Dynamic analysis:**
 - Includes mass and damping effects.
 - Modal analysis* calculates natural frequencies and mode shapes.
 - Harmonic analysis* determines a structure’s response to sinusoidal loads of known amplitude and frequency.
 - Transient Dynamic analysis* determines a structure’s response to time-varying loads and can include nonlinear behavior.
- **Other structural capabilities**
 - Spectrum analysis
 - Random vibrations
 - Eigen value buckling
 - Substructuring, submodeling
- **Explicit Dynamics with ANSYS/LS-DYNA:**
 - Intended for very large deformation simulations where inertia forces are dominant.
 - Used to simulate Impact, crushing, rapid forming, etc.
- **Thermal analysis:** is used to determine the temperature distribution in an object. Other quantities of interest include amount of heat lost or gained, thermal gradients, and thermal flux. All three primary **heat transfer** modes can be simulated: **Conduction, convection, radiation.**
 - **Steady-State** – Time dependent effects are ignored.
 - **Transient** - To determine temperatures, etc. as a function of time.
 - Allows phase change (melting or freezing) to be simulated.
- **Electromagnetic analysis:** is used to calculate magnetic fields in electromagnetic devices.
- **Static and low-frequency electromagnetics:**
 - To simulate devices operating with DC power sources, low-frequency AC, or low-frequency transient signals.
 - Example: solenoid actuators, motors, transformers
 - Quantities of interest include magnetic flux density, field intensity, magnetic forces and torques, impedance, inductance, eddy currents, power loss, and flux leakage.
- **Computational Fluid Dynamics (CFD):**–To determine the flow distributions and temperatures in a fluid.
 - ANSYS/FLOTRAN can simulate laminar and turbulent flow, compressible and incompressible flow, and multiple species.
 - Applications: aerospace, electronic packaging, automotive design.
 - Typical quantities of interest are velocities, pressures, temperatures, and film coefficients.

CHAPTER 3: Working in ANSYS

3.1 Opening ANSYS SESSION:

Ansys can be opened in Windows Operating System through

- ❖ **Start>programs>Ansys18>Interactive**
- ❖ **Start>programs>Ansys18>Run Interactive**
- ❖ **Start>programs>Ansys18>Batch**

The Interactive Option is used in the very beginning of Ansys Session to set

- Working Directory
- Default File Name
- Graphics driver
- Data Space
- Workspace
- Menus to be visible
- Command Line Arguments

Run-Interactive directly opens the Ansys Graphical user Interface (**GUI**)

Batch Utility is used to run the Programs Background.

3.2 ANSYS Menu:

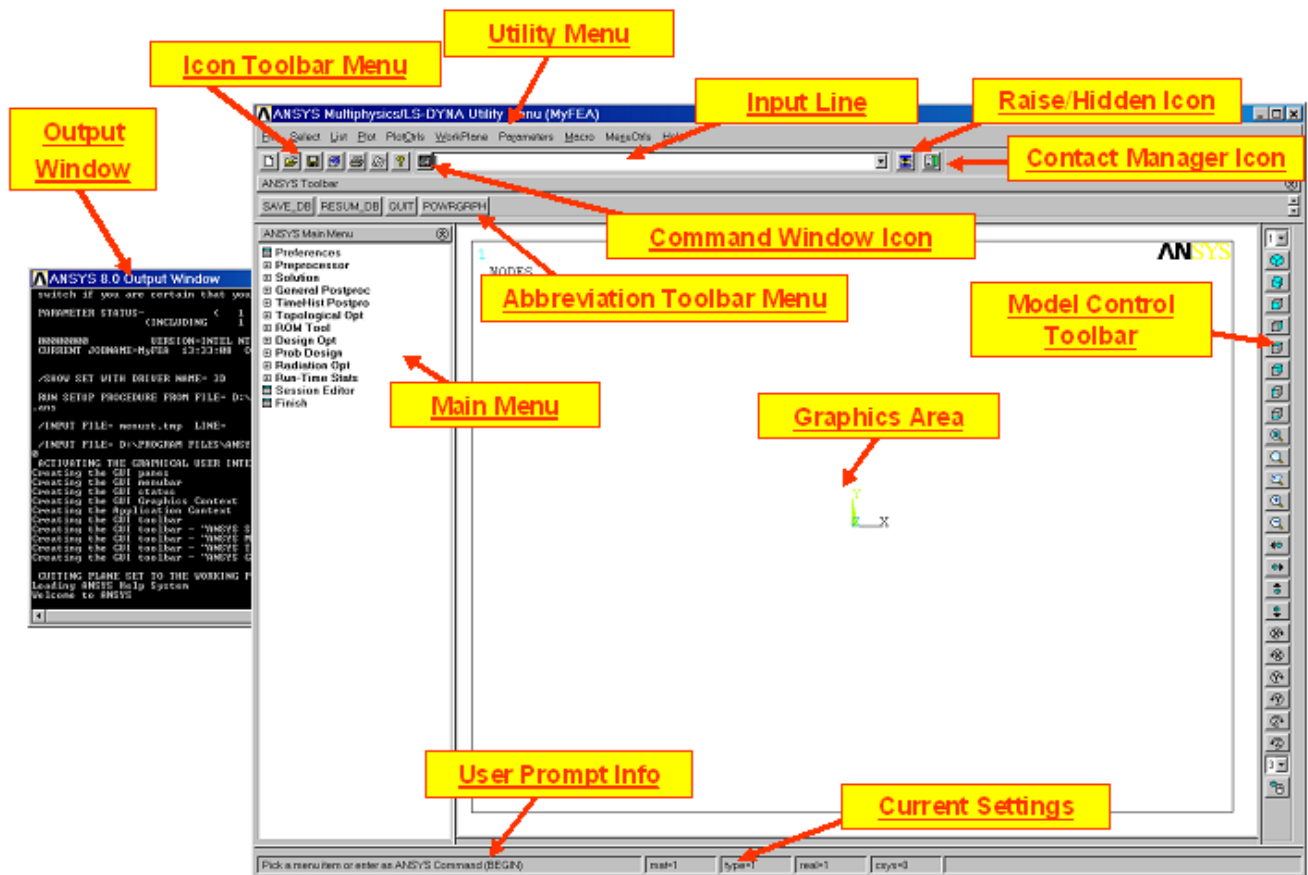

By Default ANSYS opens 6 Menus. They are

1. **Utility Menu**
2. **Main Menu**
3. **Input Window**
4. **Tool Bar**
5. **Graphics Window**
6. **Output Window**

Clear & Start New ...
Change Jobname ...
Change Title ...
Resume Jobname.db
Resume from ...
Save as Jobname.db
Save as ...
Write DB Log File ...
Read Input from ...
Switch Output to ▶
List ▶
File Operations ▶
ANSYS File Options ...
Import ▶
Export ...
Report Generator ...
Exit ...

1. This menu contains all important options as follows

a) File:

The file contains

- **Clear & Start:** To clear the database & Start a new job
- **Resume from:** To resume the previously stored job
- **Save as:** Save the database as filename.db
- **Read Input from:** if input is taken from Outside programmed file
- **Switch Output:** To external file or by default files in *.iges format is supported without any additional software. BY CATIA,UG,PRO-E you can import the geometry
- **Export:** To export to use in other software's.
- **Exit:** To close the Ansys Session.

b) Select: This is very important option for viewing the results or applying the boundary conditions. The parts of the model can be selected and can manipulate for data. This option contains

- **Entities:** Entities to be selected like key points, lines, nodes, elements, areas, volumes, etc
- **Components:** Naming and grouping the selected components.
- **Everything:** Selecting only that part
- **Everything below:** Selecting the entities below that.

c) List: This option can be used to listing the elements, nodes, volumes, forces, displacements etc.

d) Plot: This option is used to plot the areas, volumes, nodes, elements etc.

e) Plot Controls: This option is very important and contains

- **Pan Zoom Rotate:** It opens another menu through which zooming and rotation of the model is possible.
- **View Setting:** By default Z plane is perpendicular to the viewer. By this view option, view settings can be changed.
- **Numbering:** this is useful for setting on/off the entity numbering
- **Symbols:** to view the applied translations, forces, pressures, etc. this option should be used to set them on.
- **Style:** Sectioning, vector arrow sizing and real structural appearances is possible through this.
- **Window Controls:** Window positioning (9 Layout) is possible with this.
- **Animate:** Animation can be done for the output data using this.
- **Device Options:** Wireframe models can be observed through this.
- **Hard Copy:** data can be sent either to printer or any external file.
- **Capture Image:** To capture the graphics window output to a *.bmp image.
- **Multiplot Window Layout:** To view the results in more than one window.

f) Work plane: By default Z Plane is perpendicular for data input. For any changes in the global X,Y & Z planes, the workplane should be rotated to create the model or view the results.

g) Parameters: These are the scalar parameters represented with values.
Eg: b=10

h) Macros: These are grouping of Ansys commands to fulfill particular work. These can be taken equivalent to C, C++ & Java Functions.

i) Menu Controls: This can be used to set on/off the menus.

j) Help: For all the help files related to commands and topics

2. Main Menu:

This menu contains

- **Pre-processor:** This sub option can be used to build and mesh the model through proper element selection and boundary conditions.
- **Solution:** this option can be used solve the matrix equation through proper solver.
- **Post Processor:** This option is used to interpret the results.
- **Design Optimization:** This option is used to optimize the structure.
- **Time History Processor:** For dynamic problems, results can be viewed through this option.
- **Run Stats:** This option can be used to find the status of the model, time it takes for execution, computer processor capabilities, wave front size etc.

3. Input Window: This can be used to input commands or named selection.

4. Tool Bar: This contains options like saving the file, resuming the file database, Quitting the Ansys session and Graphics Type.

5. Graphics Window: This is where the model creation and plotting of results carried out.

6. Output Window: This shows the status of the work being carried out.

WORKPLANE:

Although the cursor appears as a point on the screen, it actually represents a line through space, normal to the screen. In order to define an imaginary plane that, when intersected by the normal line of the cursor, will yield a unique point in space. This imaginary plane is called a working plane.

Working plane is an infinite plane with an origin, a 2d Coordinate system, a snap increment and a display grid. You can define only one working plane at a time. (Creating a new working plane eliminates the existing working plane). The working plane is separate from the co-ordinate systems; for example; the working plane can have a different plane of origin and rotation than the active coordinate system. Work plane can be positioned wherever required and model can be created.

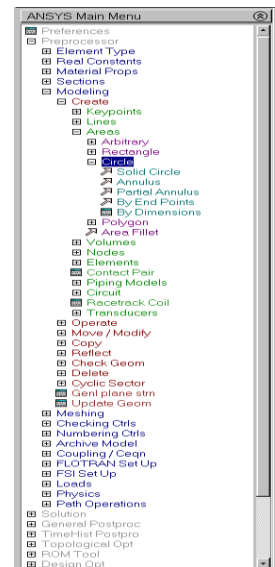

COORDINATE SYSTEM:

The ANSYS program has several types of coordinate systems, each used for a different reason:

- Global and local coordinate systems are used to locate geometry items (nodes, key points, etc.) in space.
- The display coordinate system determines the system in which geometry items are listed or displayed.

- The nodal coordinate system defines the degree of freedom directions at each node and the orientation of nodal results data.
- The element coordinate system determines the orientation of material properties and element results data.
- The results coordinate system is used to transform nodal or element results data to a particular coordinate system for listings, displays, or general postprocessing operations (POST1).

SCALAR PARAMETERS: These are useful to change the model dimensions at any time. These are useful when macros or batch programs are coded. For example in $b = 10$, b is considered as scalar parameter. For optimization the model should be represented in scalar parameters. There is another way to set parameters is $*b = 10$ and can be changed any time.

MACROS: These are grouping of commands for particular purpose. These are equivalent to functions in C and sub-routines in FORTRAN. They are very powerful and are based on APDL (Ansys Parametric Design Language). To get expertise with Ansys, one should be through with usage of Macros.

MODELING: this is the important step of creating the physical object in the system. They are two types of modeling in Ansys.

- Direct Modeling
- Solid Modeling

DIRECT MODELING: In this approach the physical structure is represented by nodes and elements directly. The problem is solved once after the boundary conditions are applied. This approach is simple and straightforward. Takes very little time computation. But this can be applied only for simple problems. When problem becomes complex, this method becomes tedious to apply.

SOLID MODELING: Models are directly created either using Ansys Preprocessor or imported from popular CAD software's like Mechanical Desktop, ProE, CATIA, SOLID WORKS, etc. Once the structural model is created, by using mesh tool, the model can be meshed and problem can be solved by applying the boundary conditions. In Ansys Solid Modeling is carried out using two methods:

Bottom Up Approach: To create model, Entities are required, Key points, Lines, Areas, and Volumes are the entities in Ansys. If model is constructed through Key points to Lines, from Lines to Areas, and From Areas to Volumes the approach of modeling is called Bottom Up Approach. This approach is useful when models are complex.

Top Down Approach_: A 3D Model can be created directly using the Volumes. Once Volumes are created, all the entities below the volumes (areas, lines, key points) are automatically created. This approach is easy but can be applied to simple problems.

ELEMENTS: Elements are FE representation of physical structures or discretized parts of the continuum. These elements are like functions designed for specific purpose. For example bar element can take only axial compressive or tensile loads. And a truss element can take only horizontal and vertical loads in the global directions. So, a truss element cannot take any transverse loading across the element or a moment. So, proper element should be selected based on the problem and loading. Usually the no. of elements of its library measures capacity of a software. Ansys contains more than 180 elements designed for specific purposes. Few of the Ansys elements are shown below.

GRAPHICS DISPLAY: There are two methods available for graphic displays.

- **Full mode display:** This option can be used with all the elements.
- **Power Graphics:** Power graphics method is the default when Ansys GUI is on. This method is valid for all the element types except for circuit elements. Power graphics method offers significantly faster performance than the full mode method.

ELEMENT TABLE: The primary data results are directly available for all elements in post processor. The secondary data or derived data (stresses, strains, Von mises stress, principal stress, etc.) is available only for solid elements. The problems where solid model is created and meshed) directly through nodal solution results in the post processor, but not available to line elements like (beam, link, etc.). To get the secondary data for line elements, we need to define the element table for the particular element to get the required data. For example to get axial stress for the link element, you must go to Ansys help, type link180 and see the link180 definitions and sequence no. for the link1. Through the post processor you have to create element table > define > by sequence no. – LS1 and plot > element tables > LS1 gives the axial stress for the problem.

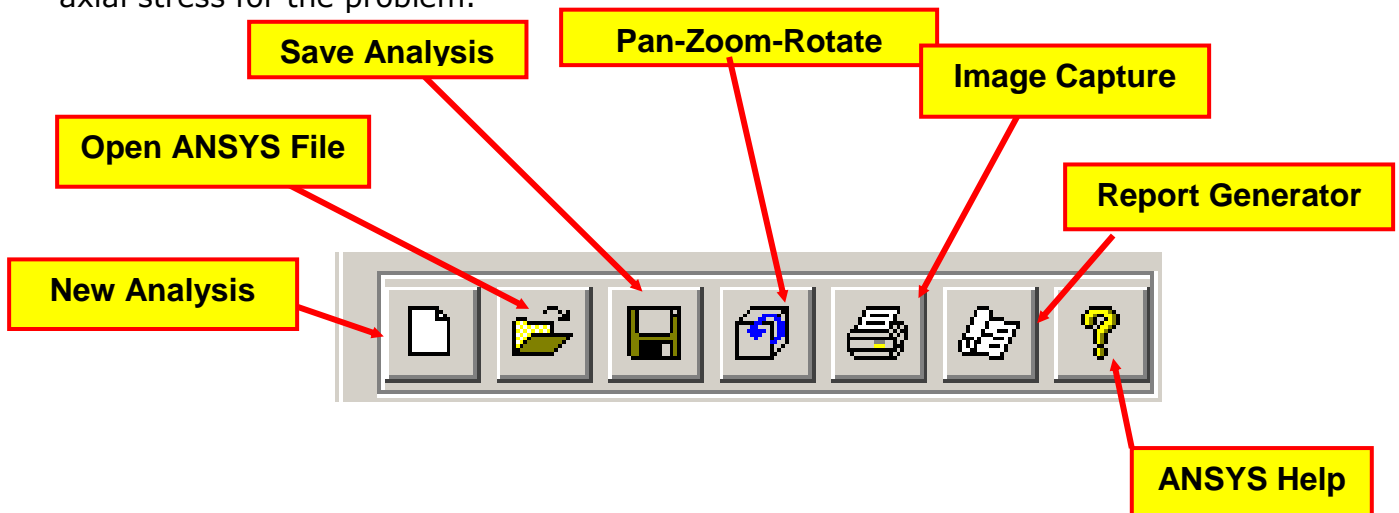

Picking & Plotting

• In this course you will be using geometrical entities such as **volumes, areas, lines and keypoints** as well as FEA entities such as **nodes and elements**. This chapter introduces the following techniques used to display and manipulate those entities within the **GUI**:

- ❖ **Plotting**
- ❖ **Picking**
- ❖ **Select Logic**
- ❖ **Components and Assemblies**

Plotting:

- It is often advantageous to plot only certain entities in the model.
- Within the **Utility Menu > Plot**, you will see that geometric, finite element and other entities can be plotted.
- With Multi-Plots, a combination of entities can be plotted.

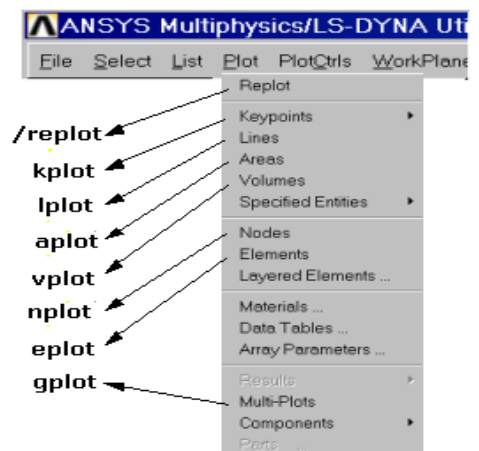

The **PlotCtrls** menu is used to control how the plot is displayed:

- plot orientation
- zoom
- colors
- symbols
- annotation
- animation
- etc.

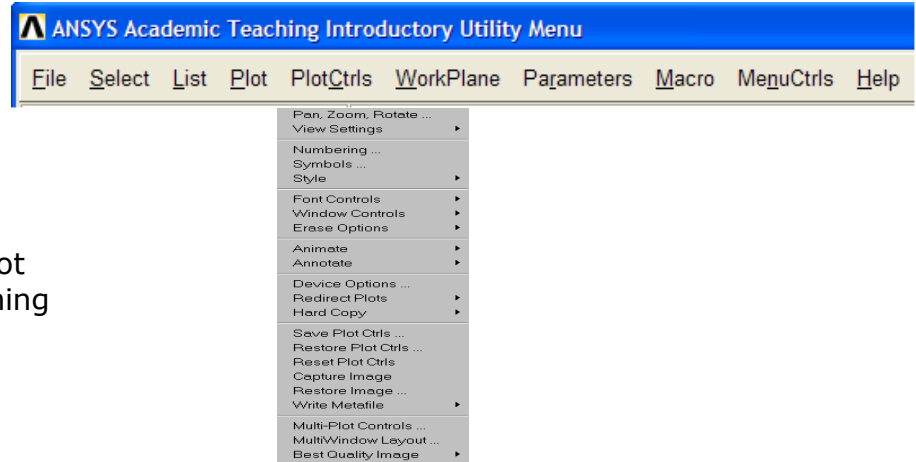

•Among these, changing the plot orientation (**/VIEW**) and zooming are the most commonly used functions.

•The default view for a model is the front view: looking down the +Z axis of the model. There are several methods to change the model view.

•**Use dynamic mode** — a way to orient the plot dynamically using the Control key and mouse buttons.
 -Ctrl + Left mouse button pans the model.

spins the model (about screen Z)
 -Ctrl + Right mouse button rotates the model:
 about screen X
 about screen Y

Note, the Shift-Right button on a two-button mouse is equivalent to the Middle mouse button on a three-button mouse.

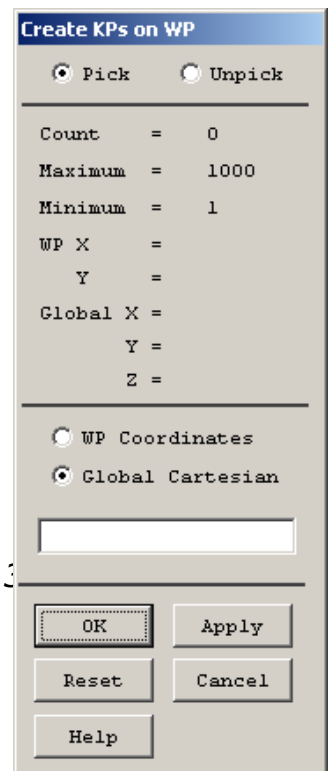
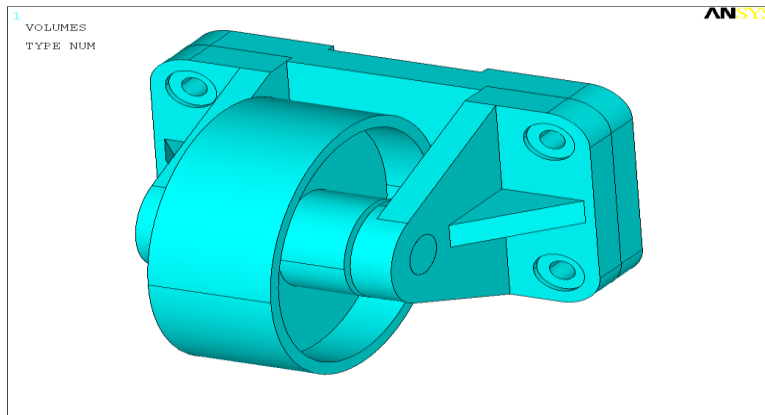

- The Model Control Toolbar also includes a dynamic rotate option.
- Picking allows you to identify model entities or locations by clicking in the Graphics Window.
- A picking operation typically involves the use of the mouse and a *picker* menu. It is indicated by a + sign on the menu.
- For example, you can create keypoints by picking locations in the Graphics Window and then pressing OK in the picker.

Two types of picking:

•Retrieval picking

–Picking existing entities for a subsequent operation.

–Use the *Pick All* button to indicate all entities.

•Locational picking

–Locating coordinates of a point, such as a keypoint or node.

–Allows you to enter coordinates in the Picker Window.

Example of Retrieval

Mouse button assignments for picking:

•**Left** mouse button picks (or unpicks) the entity or location closest to the mouse pointer. Pressing and dragging allows you to “preview” the item being picked (or unpicked).

•**Middle** mouse button does an Apply. Saves the time required to move the mouse over to the Picker and press the Apply button. Use Shift-Right button on a two-button mouse.

•**Right** mouse button toggles between pick and unpick mode.

Note, the Shift-Right button on a two-button mouse is equivalent to the Middle mouse button on a three-button mouse.

Hotspot locations for picking:

•**Areas and Volumes** have one hotspot near the centroid of the solid model entity.

•**Lines** have three hotspots - one in the middle and one near each end.

•**Why this is important:** When you are required to “pick” an entity, you must pick on the hotspot.

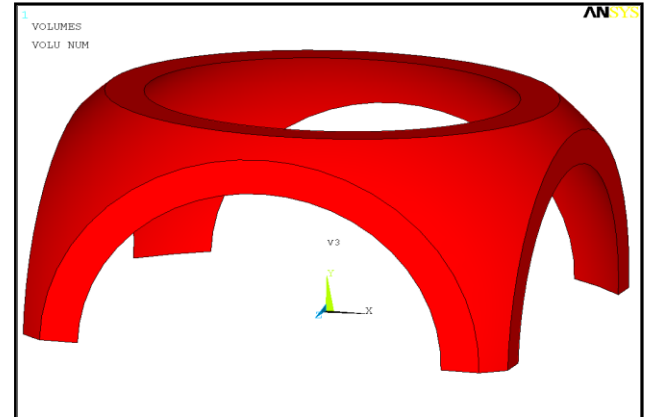
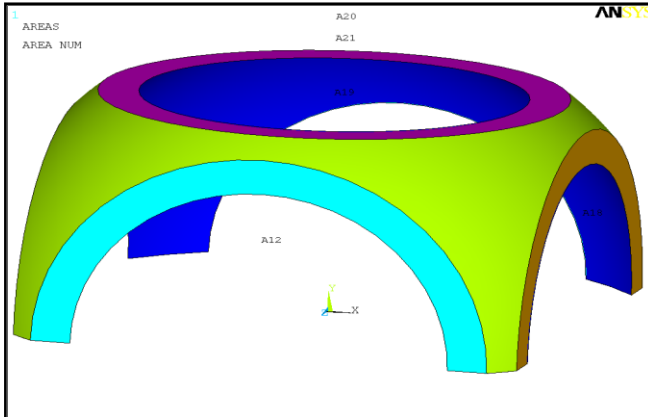

•**Note:**

- Show locational picking by creating a few keypoints. Also show the use of middle and right mouse buttons.
- Show retrieval picking by creating a few lines
- Show “Loop” by creating an AL area
- Show “Pick All” by deleting area only
- Do KPLOT, LPLLOT, etc. with and without numbering. Type in a few of these commands.
- Show the use of pan-zoom-rotate

•**Suppose you wanted to do the following:**

- Plot all areas located in the second quadrant
- Delete all arcs of radius 0.2 to 0.3 units
- Apply a convection load on all exterior lines
- Write out all nodes at Z=3.5 to a file
- View results only in elements made of steel

The **common “theme”** in these tasks is that they all operate on a **subset** of the model.

•**Select Logic** allows you to select a subset of entities and operate only on those entities.

•**Three steps:**

- Select a subset**
- Perform operations on the subset**
- Reactivate the full set**

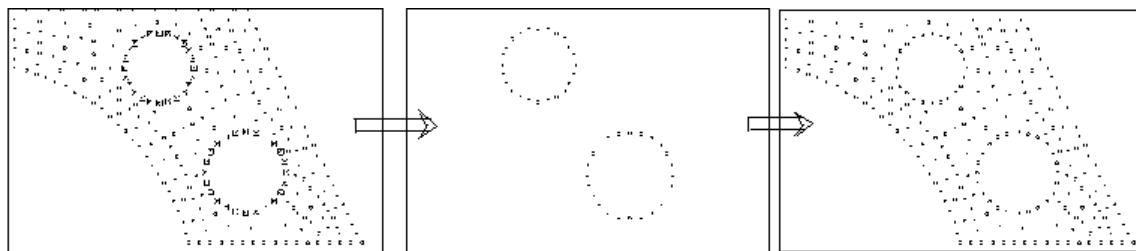

Select subset

Operate on subset

Reactivate full set

Selecting Subsets

•Most selecting tools are available in the **Select Entities** dialog box:

Utility Menu > Select > Entities...

•Or you can use the **xSEL** family of commands: KSEL, LSEL, ASEL, VSEL, NSEL, ESEL

•Criterion by which to select:

- By Num/Pick:** to select based on entity numbers or by picking
- Attached to:** to select based on attached entities. For example, select all lines attached to the current Subset of areas.
- By Location:** to select based on X, Y, Z location. For example, select all nodes at X=2.5. X, Y, Z are interpreted in the active coordinate system.
- By Attributes:** to select based on material number, real constant set number, etc. Different attributes are available for different entities.
- Exterior:** to select entities lying on the exterior.
- By Results:** to select entities by results data, e.g, nodal displacements.

•Type of selection

- From Full:** selects a subset from the full set of entities.
- Reselect:** selects (again) a subset from the current subset.
- Also Select:** adds another subset to the current subset.
- Unselect:** deactivates a portion of the current subset.
- Invert:** toggles the active and inactive subsets.
- Select None:** deactivates the full set of entities.
- Select All:** reactivates the full set of entities.

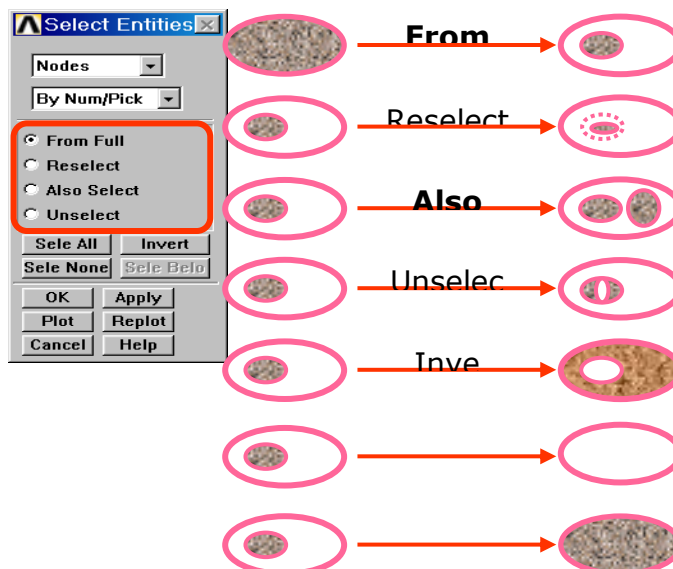
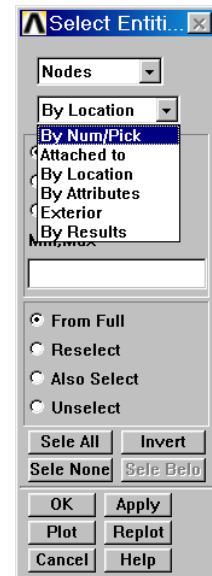
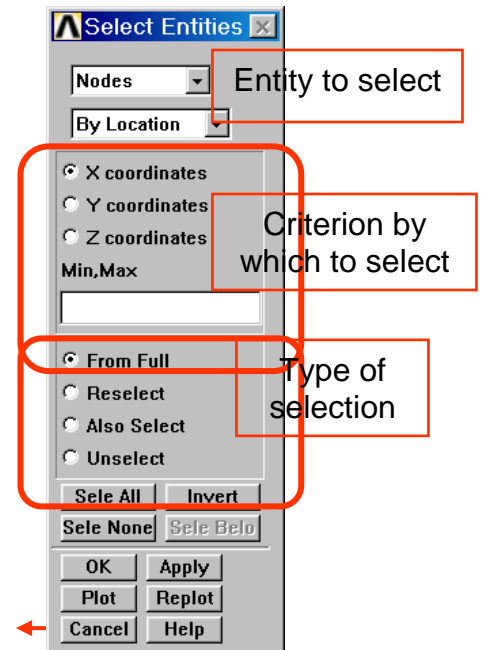

Operations on the Subset

- Typical operations are applying loads, listing results for the subset, or simply plotting the selected entities.
- The advantage of having a subset selected is that you can use the **[Pick All]** button when the picker prompts you pick desired entities. Or you can use the ALL label when using commands.
- Note that most operations in ANSYS, including the SOLVE command, act on the currently selected subset.
- Another “operation” is to assign a name to the selected subset by creating a *component* (discussed in the next section).

Reactivating the Full Set

- After all desired operations are done on the selected subset, you should reactivate the full set of entities.
- y to reactivate the full set is to select “everything”:
- **Utility Menu > Select > Everything** – Or issue the command ALLSEL
- You can also use the [Sele All] button in the Select Entities dialog box to reactivate each entity set separately. (Or issue KSEL, ALL; LSEL,ALL; etc.)

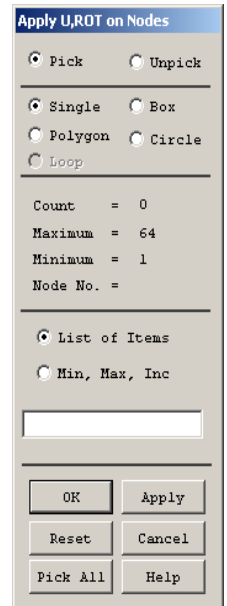

3.4 COMPONENTS:

- **Components** are user-named subsets of entities. The name can then be used in dialog boxes or commands in place of entity numbers or the label ALL.
- A group of nodes, or elements, or keypoints, or lines, or areas, or volumes can be defined as a component. Only one entity type is associated with a component.
- Components can be selected or unselected. When you select a component, you are actually selecting all of the entities in that component.
- **Component Manager** is used to Create, Display, List and Select Components and Assemblies.

– **Utility Menu > Select > Component Manager...**

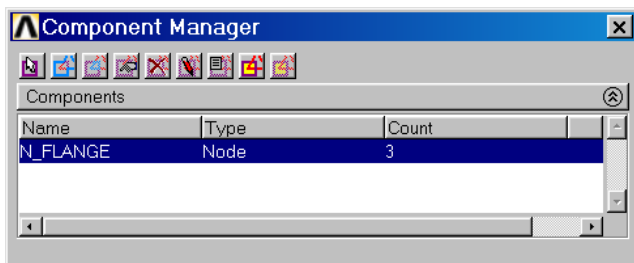

• **Creating a component**

– **Utility Menu > Select > Component Manager** – **Click on the Create Component Icon**

- All of the currently selected entities will be included in the component, or you can select (pick) the desired entities at this step.

• **Enter a name**

- Up to 32 characters - letters, numbers, and _ (underscore) - are allowed
- Beginning a component with _ (underscore) will make it a “hidden component” and it cannot be picked from the list. This is NOT recommended.
- Suggestion: Use the first letter of the name to indicate the entity type. For example, use N_HOLES for a node component.

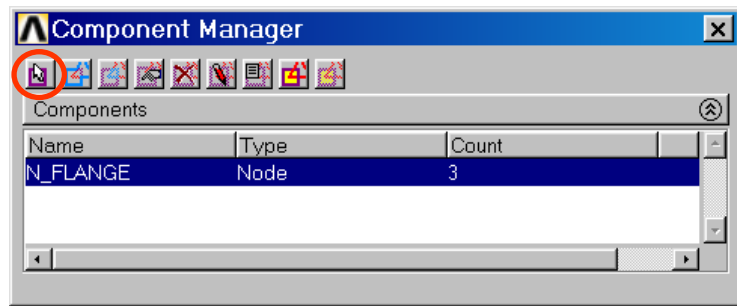
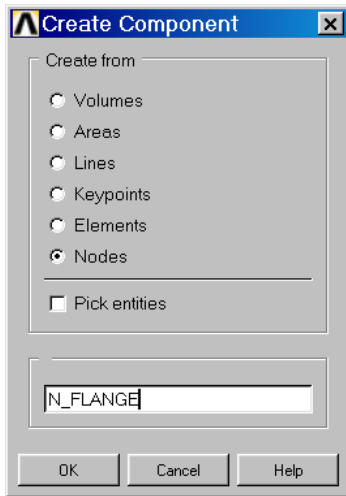

•Creating an assembly

- Highlight the components for the assembly
- Click on the Create Assembly Icon and enter a name

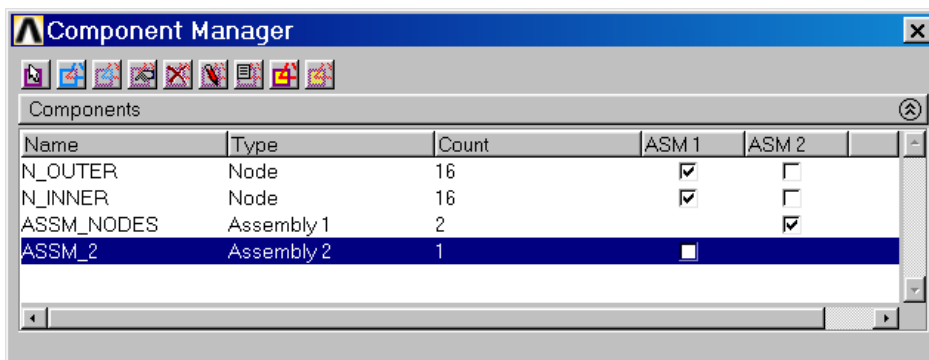

In the Component Manager above, N_OUTER and N_INNER are in the ASSM_NODES (ASM1) assembly. ASSM_NODES is in the ASSM_2 (ASM2) assembly.

Chapter 4: General Procedure in FEM

The objective of this chapter is outlining a general analysis procedure to be used to solve a simulation. Regardless of the physics of the problem, the same general procedure can be followed.

•Preliminary Decisions

–Which analysis type?

–What to model?

–Which element type?

•Preprocessing

–Define Material

–Create or import the model geometry

–Mesh the geometry

•Solution

–Apply loads

–Solve

•Postprocessing

–Review results

–Check the validity of the solution

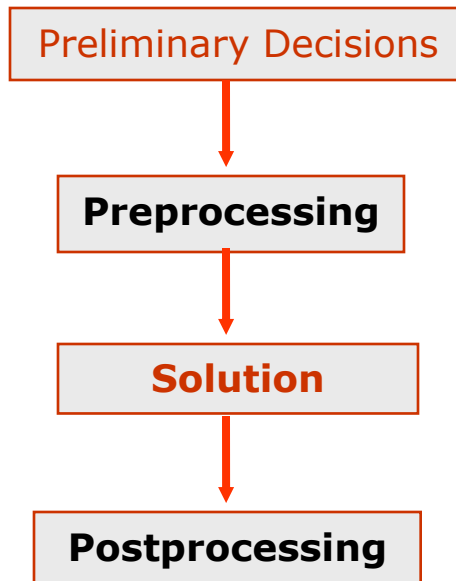

4.1 Which analysis type?

•The analysis type usually belongs to one of the following disciplines:

Structural :Motion of solid bodies, pressure on solid bodies, or contact of solid bodies

Thermal : Applied heat, high temperatures, or changes in temperature

Electromagnetic: Devices subjected to electric currents (AC or DC), electromagnetic waves, and voltage or charge excitation

Fluid :Motion of gases/fluids, or contained gases/fluids

Coupled-Field :Combinations of any

4.2 What to model?

•What should be used to model the geometry of the spherical tank?

–*Axisymmetry* since the loading, material, and the boundary conditions are symmetric. This type of model would provide the most simplified model.

–*Rotational symmetry* since the loading, material, and the boundary conditions are symmetric. Advantage over axisymmetry: offers some results away from applied boundary conditions.

–*Full 3D model* is an option, but would not be an efficient choice Compared to the axisymmetric and quarter symmetry models. If model results are significantly influenced by symmetric boundary conditions, this may be the only option.

4.3 Which Element Type?

- What element type should be used for the model of the spherical tank?
 - Axisymmetric model:•Axisymmetric since 2-D section can be revolved to created 3D geometry.
 - Linear due to small displacement assumption.

- PLANE42 with KEYOPT (3) = 1**

- Rotational symmetry model:

- Shell since radius/thickness ratio > 10

- Linear due to small displacement assumption.

- membrane stiffness only option since “membrane stresses” are required.

- SHELL63 with KEYOPT (1) = 1**

- Since the meshing of this geometry will create SHELL63 elements with shape warnings, a mid-side noded equation of the SHELL63 was used:

- SHELL93**

4.4 Create the Solid Model

- A typical solid model is defined by volumes, areas, lines, and keypoints.

- Volumes* are bounded by areas. They represent solid objects.

- Areas* are bounded by lines. They represent faces of solid objects, or planar or shell objects.

- Lines* are bounded by keypoints. They represent edges of objects.

- Keypoints* are locations in 3-D space. They represent vertices of objects.

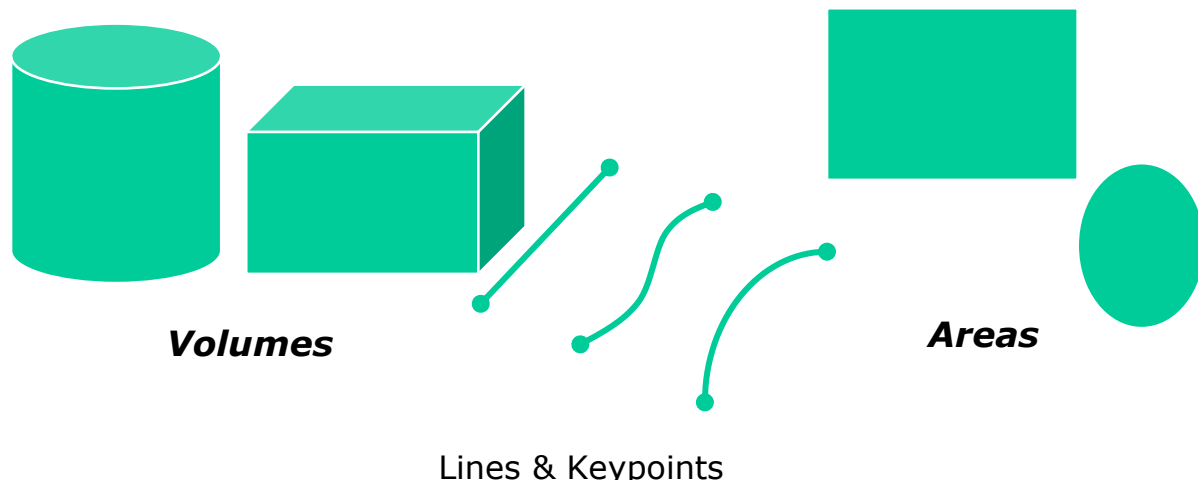

4.5 Create the FEA Model

- Meshing* is the process used to “fill” the solid model with nodes and elements, i.e, to create the FEA model.–Remember, you need nodes and elements for the finite element solution, not just the solid model. The solid model does NOT participate in the finite element solution.

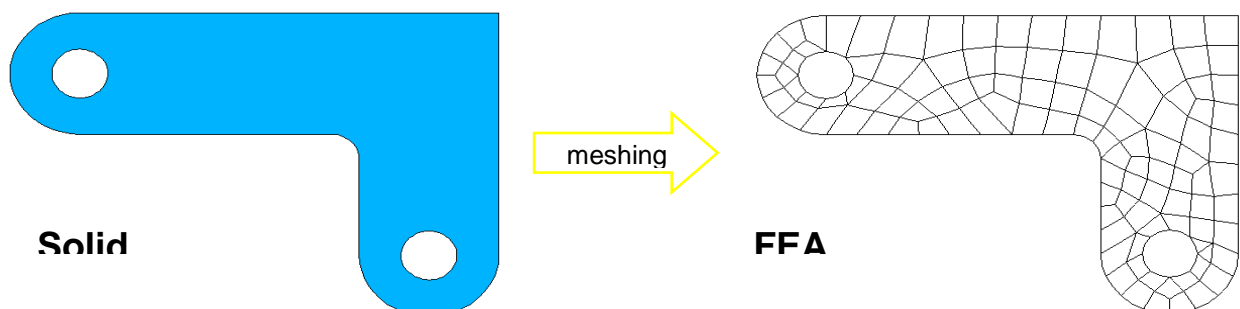

4.6 Define Material

Material Properties

- Every analysis requires *some* material property input: Young's modulus EX for structural elements, thermal conductivity KXX for thermal elements, etc.
- There are two ways to define material properties:
 - Material library
 - Individual properties

4.7 Define Loads

- There are five categories of loads:

DOF Constraints Specified DOF values, such as displacements in a stress analysis or temperatures in a thermal analysis.

Concentrated Loads Point loads, such as forces or heat flow rates.

Surface Loads Loads distributed over a surface, such as pressures or convections.

Body Loads Volumetric or field loads, such as temperatures (causing thermal expansion) or internal heat generation.

Inertia Loads Loads due to structural mass or inertia, such as gravity and rotational velocity.

4.8 Postprocessing--Review Results

- Postprocessing is the final step in the finite element analysis process.
- It is imperative that you interpret your results relative to the assumptions made during model creation and solution.
- You may be required to make design decisions based on the results, so it is a good idea not only to review the results carefully, but also to check the validity of the solution.
- ANSYS has two postprocessors:
 - POST1, the General Postprocessor, to review a single set of results over the entire model.
 - POST26, the Time-History Postprocessor, to review results at selected points in the model over time. Mainly used for transient and nonlinear analyses. (Not discussed in this course.)

4.9 Verification

- It is always a good idea to do a "sanity check" and make sure that the solution is acceptable.
- What you need to check depends on the type of problem you are solving, but here are some typical questions to ask:
 - Do the reaction forces balance the applied loads?
 - Where is the maximum stress located?
 - If it is at a singularity, such as a point load or a re-entrant corner, the value is generally meaningless.
 - Are the stress values beyond the elastic limit?
 - If so, the load magnitudes may be wrong, or you may need to do a nonlinear analysis.

4.10 Elements Used in Structural Analysis

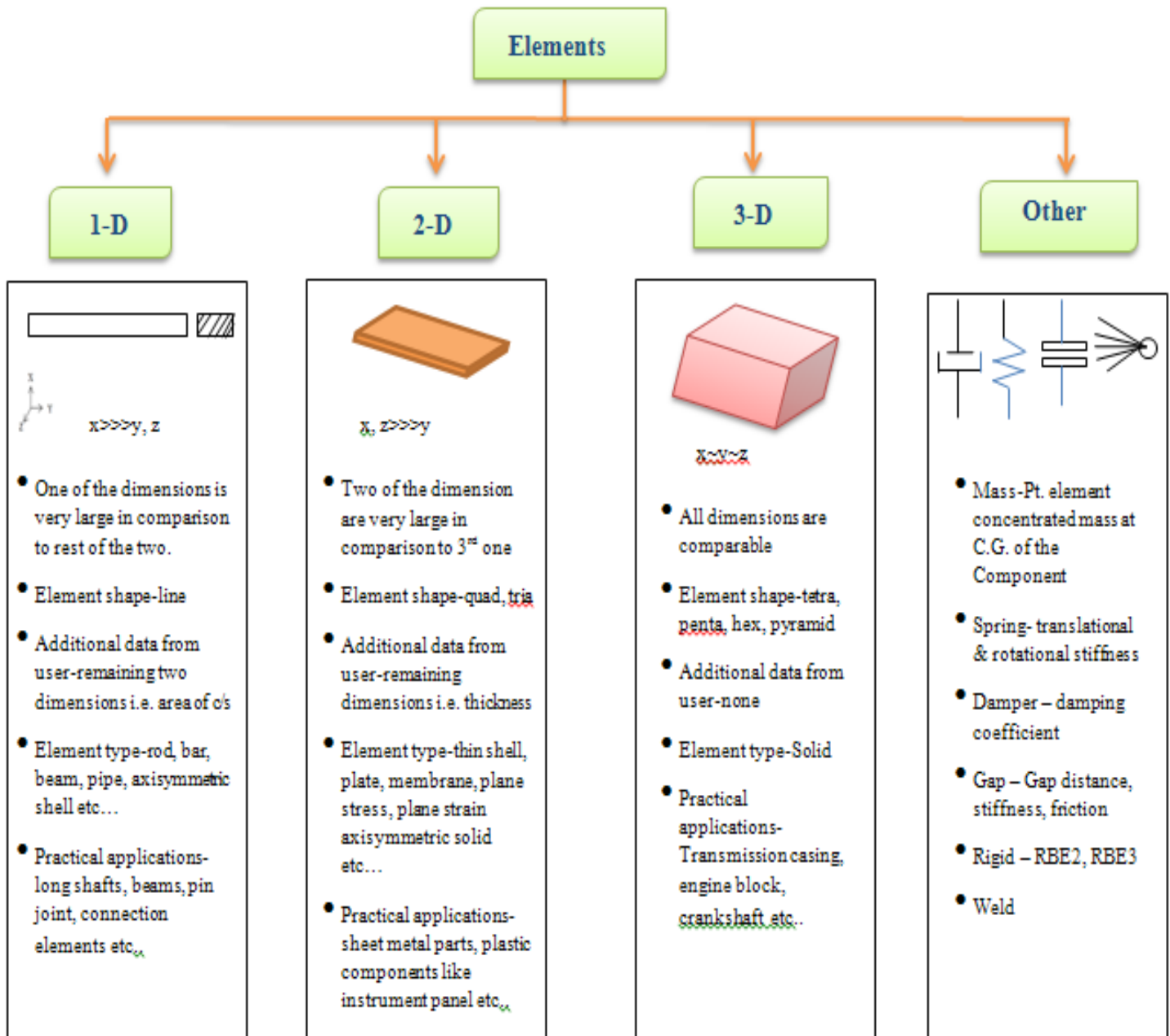

Most ANSYS element types are structural elements, ranging from simple spars and beams to more complex layered shells and large strain solids. Most types of structural analyses can use any of these elements.

Note: Explicit dynamics analysis can use only the explicit dynamic elements (LINK160, BEAM161, PLANE162, SHELL163, SOLID164, COMBI165, MASS166, and LINK167).

Structural Element Types: (NOTE - important elements normally and most commonly used in ANSYS14 are all highlighted (Bold))

Category	Element Name(s)
Spars	LINK1, LINK8, LINK10, LINK180
Beams	BEAM3, BEAM4, BEAM23, BEAM24, BEAM44, BEAM54, BEAM188, BEAM189
Pipes	PIPE16, PIPE17, PIPE18, PIPE20, PIPE59, PIPE60, PIPE288
2-D Solids	PLANE2, PLANE25, PLANE42, HYPER56, HYPER74, PLANE82, PLANE83, HYPER84, VISCO88, VISCO106, VISCO108, PLANE145, PLANE146, PLANE182, PLANE183
3-D Solids	SOLID45, SOLID46, HYPER58, SOLID64, SOLID65, HYPER86, VISCO89, SOLID92, SOLID95, VISCO107, SOLID147, SOLID148, HYPER158, SOLID185, SOLID186 , SOLID187, SOLID191
Shells	SHELL28, SHELL41, SHELL43, SHELL51, SHELL61, SHELL63, SHELL91, SHELL93, SHELL99, SHELL150, SHELL181
Thermal	LINK31, LINK33, LINK34, PLANE55
Interface	INTER192, INTER193, INTER194, INTER195
Contact	CONTAC12, CONTAC26, CONTAC48, CONTAC49, CONTAC52, TARGE169, TARGE170, CONTA171, CONTA172, CONTA173, CONTA174, CONTA175
Coupled-Field	SOLID5, PLANE13, FLUID29, FLUID30, FLUID38, SOLID62, FLUID79, FLUID80, FLUID81, SOLID98, FLUID129, INFIN110, INFIN111, FLUID116, FLUID130
Specialty	COMBIN7, LINK11, COMBIN14, MASS21 , MATRIX27, COMBIN37, COMBIN39, COMBIN40, MATRIX50, SURF153, SURF154
Explicit Dynamics	LINK160, BEAM161, PLANE162, SHELL163, SOLID164, COMBI165, MASS166, LINK167

4.11 Types of Elements

Few important FEM elements are as follows

TRUSS: Slender element ($\text{Length} \gg \text{area}$) which supports only tension or compression along its length, essentially a 1D spring

BEAM: Slender element whose length is much greater than its transverse dimension which supports lateral loads, which cause flexural bending.

2D SOLID: Element whose geometry definition lies in a plane and applies loads also lie in the same plane. Plane stress occurs for structures with small thickness compared with its in-plane dimension- stress components associated with the out-of-plane coordinate are zero. Plane strain occurs for structures where the thickness becomes large compared to its in-plane dimension-strain component associated with the out-of-plane coordinate are zero.

PLATE: Element whose geometry lies in the plane with loads acting out of the plane which cause flexural bending and with both in-plane dimensions large in comparison to its thickness- two-dimensional state of stress exists similar to plane stress except that there is a variation of tension through the thickness.

SHELLS: Element similar in character to a plate but typically used on curved surfaces and supports both in-plane and out-of-plane loads. Numerous formulations exist.

3D SOLID: Element classification that covers all elements – element obeys the strain displacement and stress-strain relationships.

Beam/ Truss Elements



2 Node(Linear)



3 Node(Quadratic)



4 Node(Cubic)

Triangular Elements



3 Node(Linear)



6 Node(Quadratic)



10 Node(Cubic)

Tetrahedral Elements

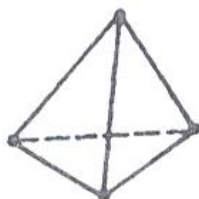

4 Node(Linear)

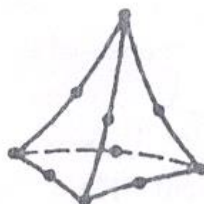

10 Node(Quadratic)

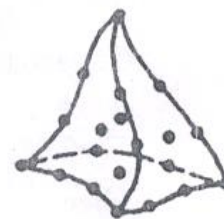

20 Node(Cubic)

Chapter5: Trusses

A truss structure consists of only two force members. Therefore every truss element is in direct tension or compression. Loads are applied only at joints. The joints are assumed to be frictionless. i.e., pin joints. FEM can easily handle truss problems whether statically determinate and indeterminate. Also it can provide joint deflection and handle temperature changes.

LINK180 Assumptions and Restrictions

- The spar element assumes a straight bar, axially loaded at its ends and of uniform properties from end to end.
- The length of the spar must be greater than zero, so nodes I and J must not be coincident.
- The cross-sectional area must be greater than zero.
- The temperature is assumed to vary linearly along the length of the spar.
- The displacement shape function implies a uniform stress in the spar.
- Stress stiffening is always included in geometrically nonlinear analyses (NLGEOM, ON). Prestress effects can be activated by the PSTRES command.
- To simulate the tension-/compression-only options, a nonlinear iterative solution approach is necessary.

In Ansys 3D-spar Element is referred to as **Link180**.

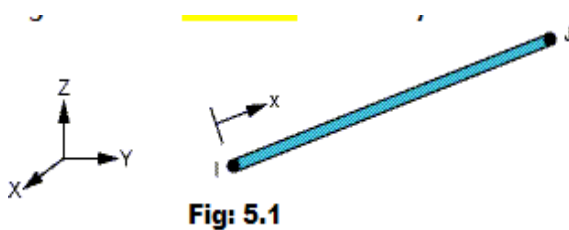

LINK180 is a 3-D spar that is useful in a variety of engineering applications. The element can be used to model trusses, sagging cables, links, springs, and so on. The element is a uniaxial tension-compression element with three degrees of freedom at

each node: translations in the nodal x, y, and z directions. Tension-only (cable) and compression-only (gap) options are supported. As in a pin-jointed structure, no bending of the element is considered. Plasticity, creep, rotation, large deflection, and large strain capabilities are included.

By default, LINK180 includes stress-stiffness terms in any analysis that includes large-deflection effects. Elasticity, isotropic hardening plasticity, kinematic hardening plasticity, Hill anisotropic plasticity, Chaboche nonlinear hardening plasticity, and creep are supported. To simulate the tension-/compression-only options, a nonlinear iterative solution approach is necessary; therefore, large-deflection effects must be activated (NLGEOM,ON) prior to the solution phase of the analysis.

See **LINK180** in the Mechanical APDL Theory Reference for more details about this element.

LINK180 Input Data: The geometry, node locations, and the coordinate system for this element are shown in Figure 5.1 The element is defined by two nodes, the cross-sectional area (AREA), added mass per unit length (ADDMAS), and the material properties. The element X-axis is oriented along the length of the element from node I toward node J.

Element loads are described in Nodal Loading. Temperatures may be input as element body loads at the nodes. The node I temperature T(I) defaults to TUNIF. The node J temperature T(J) defaults to T(I).

LINK180 allows a change in cross-sectional area as a function of axial elongation. By default, the cross-sectional area changes such that the volume of the element is preserved, even after deformation. The default is suitable for elastoplastic applications. By using KEYOPT (2), you may choose to keep the cross section constant or rigid.

LINK180 offers tension-only or compression-only options. You can specify the desired behavior via the third real constant. (See "LINK180 Input Summary" for details.) A nonlinear solution procedure is necessary for these options; for more information, see the documentation for the SOLCONTROL command.

You can apply an initial stress state to this element via the INISTATE command. For more information, see "Initial State" in the Basic Analysis Guide.

The "LINK180 Input Summary" table summarizes the element input. Element Input gives a general description of element input.

LINK180 Input Summary

Nodes	I, J
Degrees of Freedom	UX, UY, UZ
Real Constants	Cross-sectional AREA (ANSYS17 & below)
SECTIONS	LINK section (ANSYS18)
ADDMAS -	Added mass (mass/length)
TENSKEY -	Tension- or compression-only option:
0 --	Tension and compression (default)
1 --	Tension only
-1 --	Compression only
Material Properties	EX, (PRXY or NUXY), ALPX (or CTEX or THSX), DENS, GXY, ALPD, BETD
Surface Loads	None
Body Loads	Temperatures -- T(I), T(J)
KEYOPT (2)	Cross-section scaling (applies only if large-deflection effects [NLGEOM,ON] apply):
0 --	Enforce incompressibility; cross section is scaled as a function of axial stretch. (default).
1 --	Section is assumed to be rigid.

LINK180 Output Data:

The solution output associated with the element is in two forms:

- Nodal displacements included in the overall nodal solution
- Additional element output several items are illustrated in Figure 180.2. A general description of solution output is given in Solution Output. Element results can be viewed in POST1 with PRESOL, ELEM. See the Basic Analysis Guide for details.

LINK180 Stress Output:



The Element Output Definitions table uses the following notation:

A colon (:) in the Name column indicates that the item can be accessed by the Component Name method (ETABLE, ESOL). The O column indicates the availability of the items in the file Jobname. OUT. The R column indicates the availability of the items in the results file.

Table 5.1 LINK180 Element Output Definitions

Name	Definition	O	R
EL	Element number	Y	Y
NODES	Nodes - I, J	Y	Y
MAT	Material number	Y	Y
REAL	Real constant number	Y	Y
XC, YC, ZC	Center location	Y	<u>1</u>
TEMP	Temperatures T(I), T(J)	Y	Y
AREA	Cross-sectional area	Y	Y
FORCE	Member force in the element coordinate system	Y	Y
Sxx	Axial stress	Y	Y
EPeLxx	Axial elastic strain	Y	Y
EPTOxx	Total strain	Y	Y
EPEQ	Plastic equivalent strain	<u>2</u>	<u>2</u>
Cur.Yld.Flag	Current yield flag	<u>2</u>	<u>2</u>
Plwk	Plastic strain energy density	<u>2</u>	<u>2</u>
Pressure	Hydrostatic pressure	<u>2</u>	<u>2</u>
Creq	Creep equivalent strain	<u>2</u>	<u>2</u>
Crwk_Creep	Creep strain energy density	<u>2</u>	<u>2</u>
EPPLxx	Axial plastic strain	<u>2</u>	<u>2</u>
EPCRxx	Axial creep strain	<u>2</u>	<u>2</u>
EPThxx	Axial thermal strain	<u>3</u>	<u>3</u>

In either the O or R columns, "Y" indicates that the item is always available, a number refers to a table footnote that describes when the item is conditionally available, and "-" indicates that the item is not available

Available only at the centroid as a ***GET** item.

Available only if the element has an appropriate nonlinear material.

Available only if the element temperatures differ from the reference temperature.

The element printout also includes 'INT, SEC PTS' (which are always '1, Y Z' where Y and Z both have values of 0.0). These values are printed to maintain formatting consistency with the output printouts of the BEAM188, BEAM189, PIPE288, and PIPE289 elements.

Table 5.1: LINK180 Item and Sequence Numbers lists output available through ETABLE using the Sequence Number method. See The General Postprocessor (POST1) in the Basic Analysis Guide and The Item and Sequence Number Table in this manual for more information. The following notation is used in Table 5.2: LINK180 Item and Sequence Numbers: Name output quantity as defined in Table 5.1: LINK180 Element Output Definitions Item predetermined Item label for ETABLE and ESOL sequence number for single-valued or constant element data I,J sequence number for data at nodes I and J

Table 5.2 **LINK180** Item and Sequence Numbers

Output Quantity Name	ETABLE and ESOL Command Input			
	Item	E	I	J
Sxx	LS	-	1	2
EPELxx	LEPEL	-	1	2
EPTOxx	LEPTO	-	1	2
EPTHxx	LEPTH	-	1	2
EPPLxx	LEPPL	-	1	2
EPCRxx	LEPCR	-	1	2
FORCE	SMISC	1	-	-
AREA	SMISC	2	-	-
TEMP	LBFE	-	1	2

Boundary conditions for different supports:

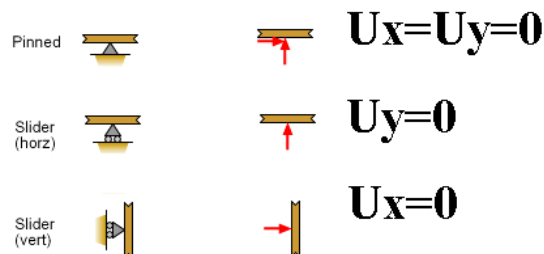

Problem 1: Determine the nodal deflections, reaction forces, and stress for the truss system shown below: Take Young's modulus = 200GPa, cross section area = 3250mm².

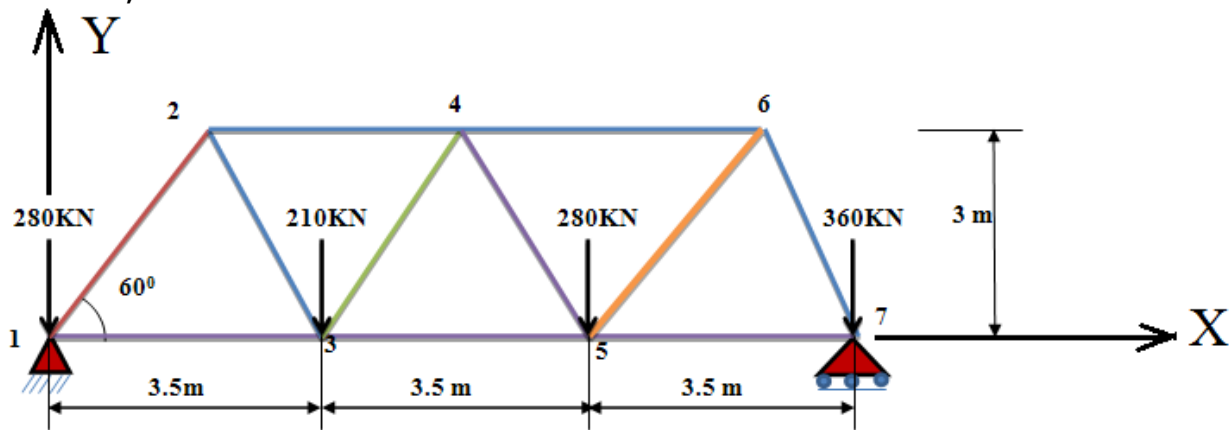

Preprocessing: Defining the Problem

1. Give the Simplified Version a Title (such as '**Bridge Truss Tutorial**'). In the **Utility menu bar select File > Change Title:**

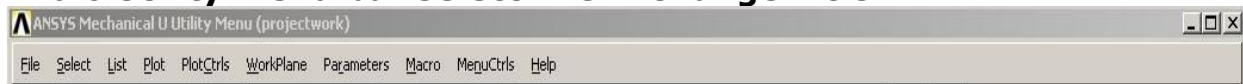

The following window will appear:

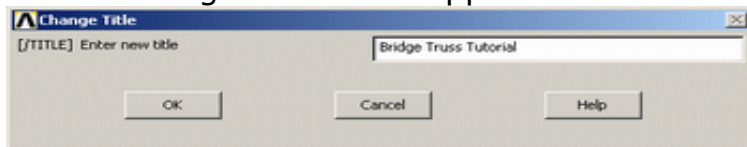

Enter the title and click 'OK'. This title will appear in the bottom left corner of the 'Graphics' Window once you begin. Note: to get the title to appear immediately, select **Utility Menu > Plot > Replot**

2. Enter Key points

The overall geometry is defined in ANSYS using key points, which specify various principal coordinates to define the body. For this example, these **keypoints** are the ends of each truss. We are going to define 7 keypoints for the simplified structure as given in the following table.

keypoint	coordinates		
	x	y	z
1	0	0	0
2	1750	3000	0
3	3500	0	0
4	5250	3000	0
5	7000	0	0
6	8750	3000	0
7	10500	0	0

- (these keypoints are depicted by numbers in the above figure)
- From the '**ANSYS Main Menu**' select:
Preprocessor > Modeling > Create > Key points > In Active

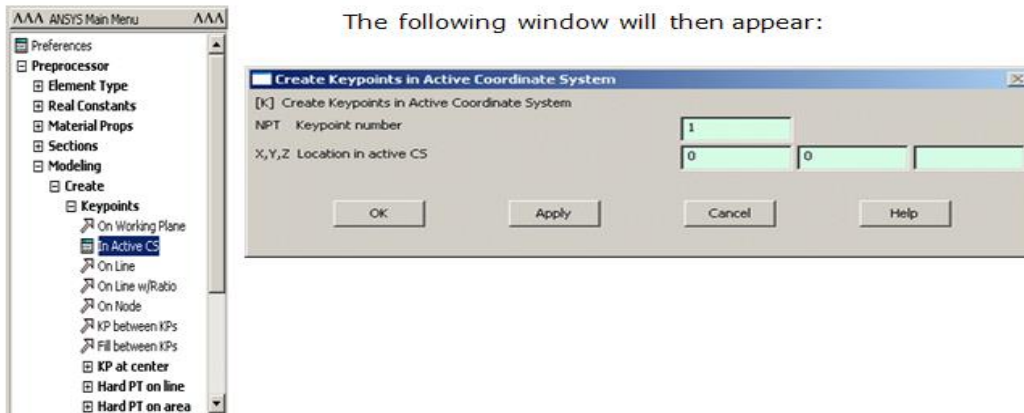

CS

To define the first keypoint which has the coordinates $x = 0$ and $y = 0$: Enter keypoint number 1 in the appropriate box, and enter the x,y coordinates: 0, 0 in their appropriate boxes (as shown above). Click 'Apply' to accept what you have typed. Enter the remaining keypoints using the same method.

Note: When entering the final data point, click on 'OK' to indicate that you are finished entering keypoints. If you first press 'Apply' and then 'OK' for the final keypoint, you will have defined it twice! If you did press 'Apply' for the final point, simply press 'Cancel' to close this dialog box.

Units: Note the units of measure (ie mm) were not specified. It is the responsibility of the user to ensure that consistent sets of units are used for the problem; thus making any conversions where necessary.

Correcting Mistakes

When defining keypoints, lines, areas, volumes, elements, constraints and loads you are bound to make mistakes. Fortunately these are easily corrected so that you don't need to begin from scratch every time an error is made! Every 'Create' menu for generating these various entities also has a corresponding 'Delete' menu for fixing things up.

Form Lines

The keypoints must now be connected

We will use the mouse to select the keypoints to form the lines.

- In the main menu select:
- **Preprocessor > Modeling > Create > Lines > Lines > In Active Coord.** The following window will then appear:

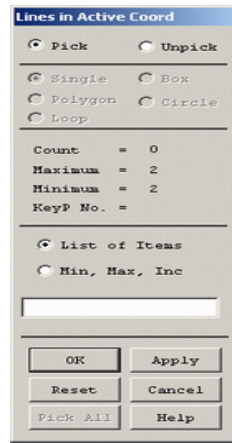

Use the mouse to pick keypoint #1 (i.e. click on it). It will now be marked by a small yellow box. Now move the mouse toward keypoint #2.

A line will now show on the screen joining these two points. Left click and a permanent line will appear. Connect the remaining keypoints using the same method.

When you're done, click on 'OK' in the 'Lines in Active Coord' window, minimize the 'Lines' menu and the 'Create' menu. Your ANSYS Graphics window should look similar to the following figure in next page.

Disappearing Lines:

Please note that any lines you have created may 'disappear' throughout your analysis. However, they have most likely NOT been deleted. If this occurs at any time from the Utility Menu select: Plot > Lines

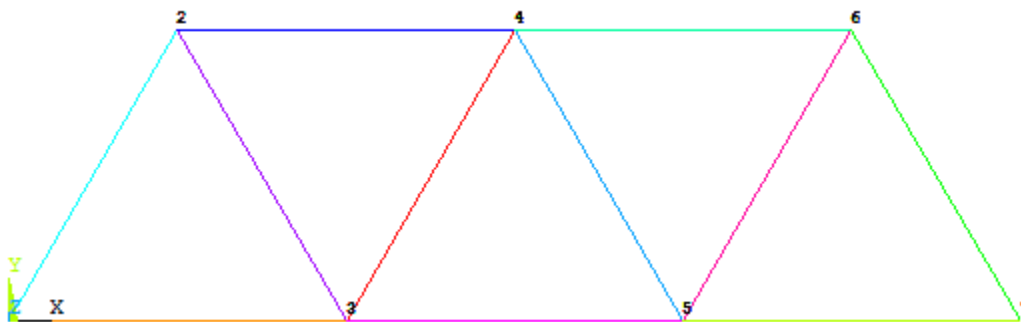

3. Define the Type of Element

It is now necessary to create elements. This is called 'meshing'. ANSYS first needs to know what kind of elements to use for our problem:

From the **Preprocessor** Menu, select: **Element Type > Add/Edit/Delete**.

The following window will then appear:



Click on the 'Add...' button. The following window will appear:

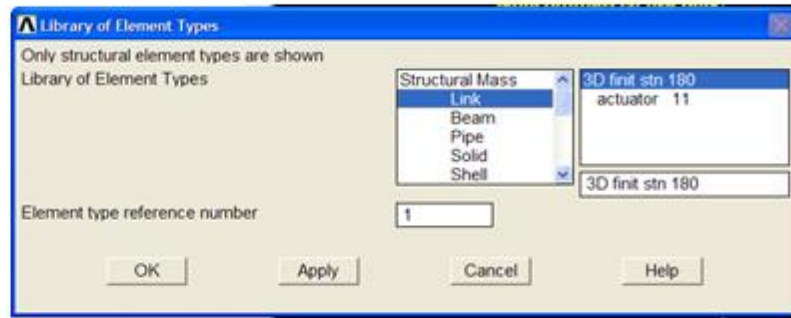

For this example, we will use the **3D finit stn 180 element** as selected in the above figure. Select the element shown and click 'OK'. You should see '**Type 1 LINK180**' in the '**Element Types**' window.

Click on '**Close**' in the '**Element Types**' dialog box.

4. Define Geometric Properties

[In ANSYS17.0 or below]:

We now need to specify geometric properties for our elements:

In the Preprocessor menu, select **Real Constants > Add/Edit/Delete** Click **Add...** and select '**Type LINK180**' (actually it is already selected). Click on 'OK'. The following window will appear:



As shown in the window above, enter the cross-sectional area (3250mm): Click on 'OK'. 'Set 1' now appears in the dialog box. Click on 'Close' in the 'Real Constants' window.

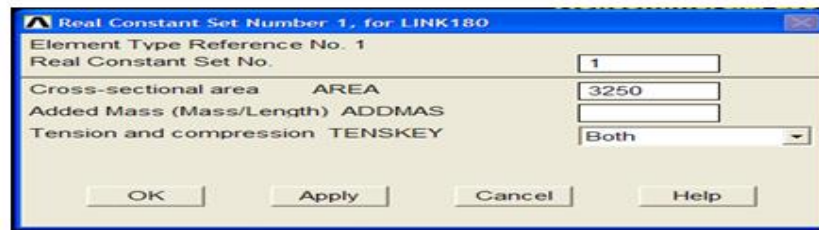

[In ANSYS18.0]:

Preprocessor > Sections > Link > Add > Add Link section with ID=1, Section Name= 'rect', Area=3250 > ok

NOTE: In ANSYS 18.0, real constants are not supported for LINK180 element. Hence, in order to define the cross section, the given area is assumed to be square for simplicity (Or It can be any other type of section).

Element Material Properties

You then need to specify material properties:

In the 'Preprocessor' menu select **Material Props > Material Models**

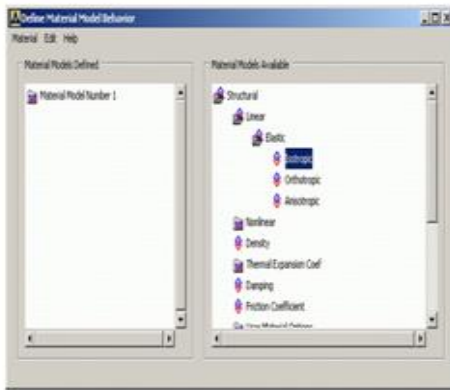

Double click on Structural >Linear>Elastic>Isotropic

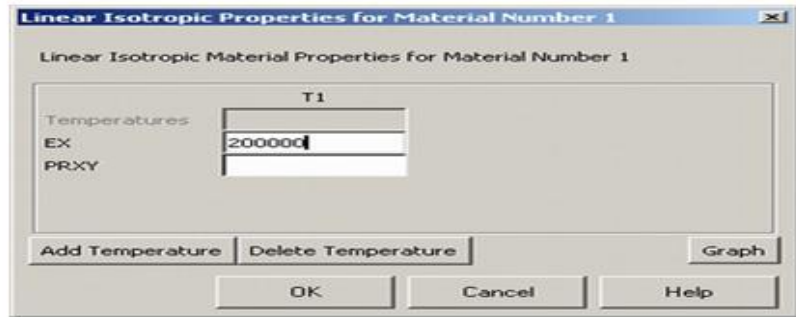

We are going to give the properties of Steel. Enter the following field:
EX 200000

Set these properties and click on 'OK'. Note: You may obtain the note 'PRXY will be set to 0.0'. This is poisson ratio and is not required for this element type. Click 'OK' on the window to continue. Close the "Define Material Model Behavior" by clicking on the 'X' box in the upper right hand corner.

Mesh Size

The last step before meshing is to tell ANSYS what size the elements should be. There are a variety of ways to do this but we will just deal with one method for now.

- In the Preprocessor menu select **Meshing > Size Cntrls > ManualSize > Lines > All Lines**

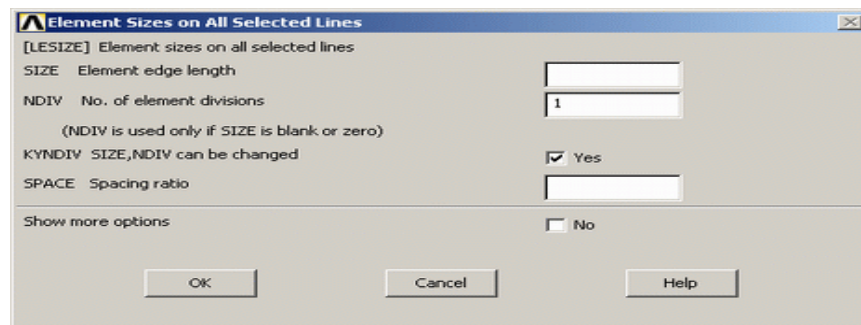

- In the size '**NDIV**' field, enter the desired number of divisions per line. **For trusses we want only 1 division per line**, therefore, enter '**1**' and then click 'OK'. Note that we have not yet meshed the geometry. We have simply defined the element sizes.

5. Mesh

Now the frame can be meshed.

- In the 'Preprocessor' menu select **Meshing > Mesh > Lines** and click '**Pick All**' in the 'Mesh Lines' Window

Your model should now appear as shown in the following window

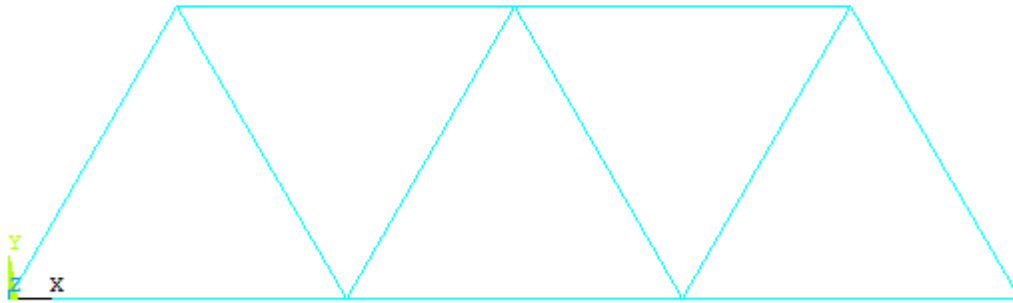

Plot Numbering: To show the line numbers, keypoint numbers, node numbers...

- From the Utility Menu (top of screen) select PlotCtrls > Numbering...
- Fill in the Window as shown below and click 'OK'
- Fill in the Window as shown below and click 'OK'
- Now you can turn numbering on or off at your discretion

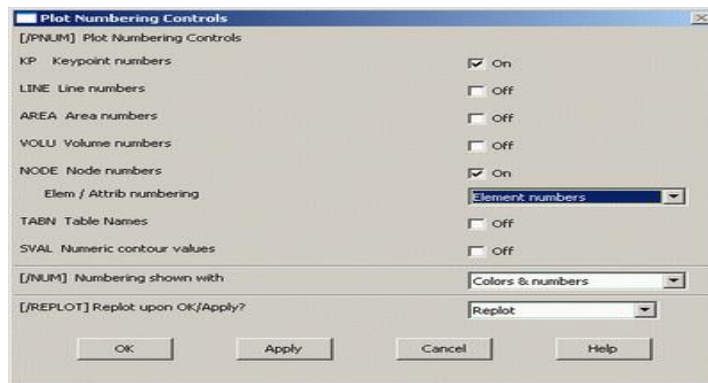

Saving Your Work

Save the model at this time, so if you make some mistakes later on, you will at least be able to come back to this point. To do this, on the **Utility Menu select File > Save as....** Select the name and location where you want to save your file.

It is a good idea to save your job at different times throughout the building and analysis of the model to backup your work in case of a system crash or what have you.

Solution Phase: Assigning Loads and Solving

You have now defined your model. It is now time to apply the load(s) and constraint(s) and solve the the resulting system of equations. Open up the 'Solution' menu (from the same 'ANSYS Main Menu').

1. Define Analysis Type

First you must tell ANSYS how you want it to solve this problem:

- From the Solution Menu, select **Analysis Type > New Analysis.**

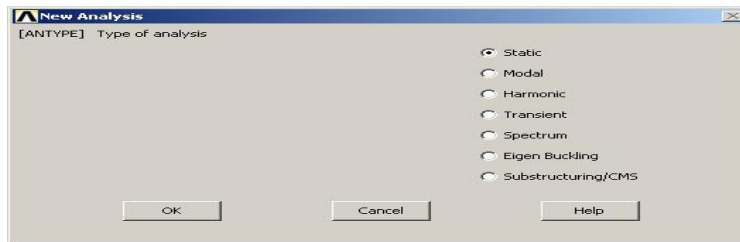

- Ensure that 'Static' is selected; i.e. you are going to do a static analysis on the truss as opposed to a dynamic analysis, for example.
- Click 'OK'.

2. Apply Constraints

It is necessary to apply constraints to the model otherwise the model is not tied down or grounded and a singular solution will result. In mechanical structures, these constraints will typically be fixed, pinned and roller-type connections. As shown above, the left end of the truss bridge is pinned while the right end has a roller connection.

- In the Solution menu, select **Define Loads > Apply > Structural > Displacement > On Keypoints**
- Select the left end of the bridge (Keypoint 1) by clicking on it in the Graphics Window and click on 'OK' in the 'Apply **All DOF** on KPs' window.

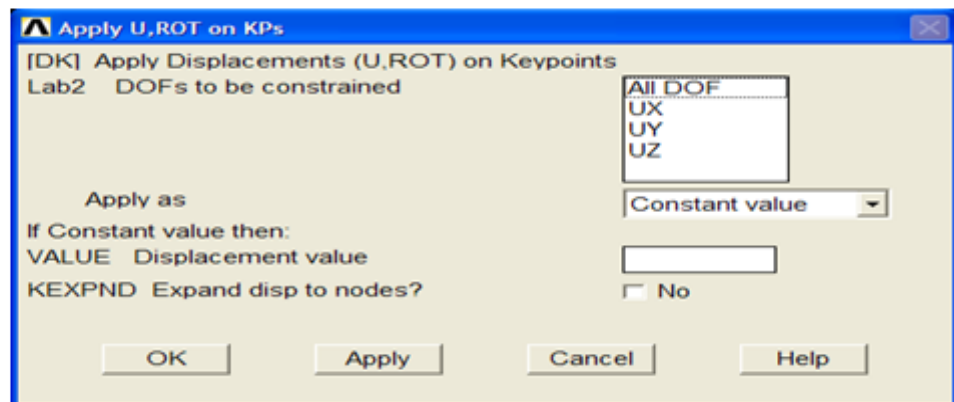

- This location is fixed which means that all translational and rotational degrees of freedom (DOFs) are constrained. Therefore, select '**All DOF**' by clicking on it and enter '0' in the Value field and click '**OK**'.

You will see some blue triangles in the graphics window indicating the displacement constraints.

- Using the same method, apply the roller connection to the right end (**UY and UZ=0**). **Note** that more than one DOF constraint can be selected at a time in the window. Therefore, you may need to 'deselect' the '**All DOF**' option to select just the '**UY, UZ**' option.

3. Apply Loads

As shown in the diagram, there are four downward loads of 280kN, 210kN, 280kN, and 360kN at keypoints 1, 3, 5, and 7 respectively.

- Select **Define Loads > Apply > Structural > Force/Moment > on Keypoints**.
- Select the first Keypoint (left end of the truss) and click 'OK' in the 'Apply F/M on KPs' window.

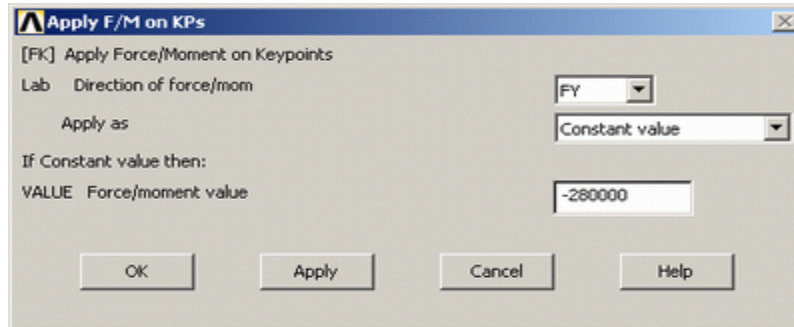

- Select **FY** in the '**Direction of force/mom**'. This indicates that we will be applying the load in the 'y' direction.
 - Enter a value of **-280000** in the '**Force/moment value**' box and click 'OK'. Note that we are using units of N here, this is consistent with the previous values input.
 - The force will appear in the graphics window as a red arrow.
 - Apply the remaining loads in the same manner.
- The applied loads and constraints should now appear as shown below.

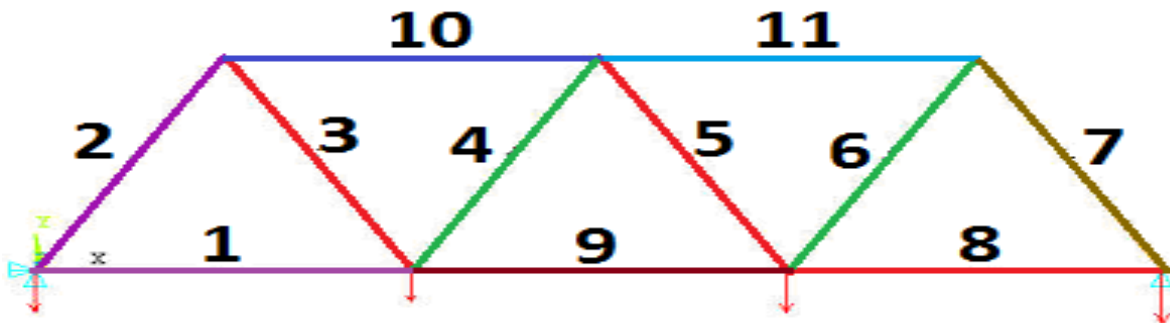

4. Solving the System

We now tell ANSYS to find the solution:

- In the 'Solution' menu select **Solve > Current LS**. This indicates that we desire the solution under the current Load Step (LS).

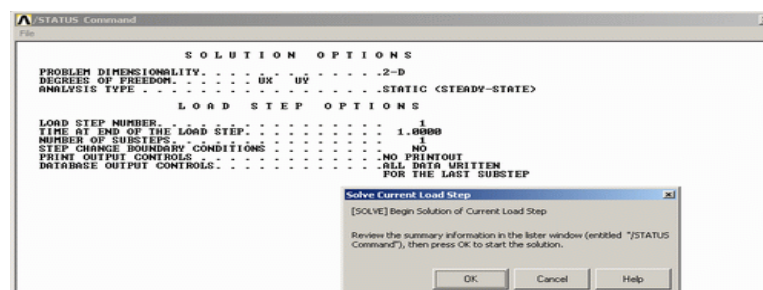

The above windows will appear. Ensure that your solution options are the same as shown above and click '**OK**'.

Once the solution is done the following window will pop up. Click '**Close**' and close the /STATUS Command Window.

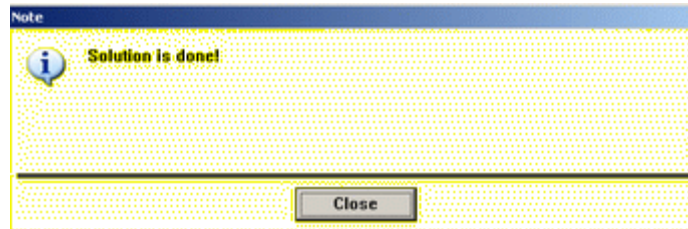

Postprocessing: Viewing the Results

➤ List deflection:

General Postproc > List Results > Nodal Solution select '**DOF Solution**' and '**Displacement vector sum**' from the lists in the '**List Nodal Solution**' window and click 'OK'. This means that we want to see a listing of all degrees of freedom from the solution.

```

PRINT U      NODAL SOLUTION PER NODE
***** POST1 NODAL DEGREE OF FREEDOM LISTING *****
LOAD STEP=   1   SUBSTEP=   1
TIME=   1.0000   LOAD CASE=   0

THE FOLLOWING DEGREE OF FREEDOM RESULTS ARE IN THE GLOBAL COORDINATE SYSTEM

   NODE      UX          UY          UZ          USUM
   1         0.0000         0.0000         0.0000         0.0000
   2         0.73291        -6.4487         0.0000         6.4982
   3         3.0293         -3.4381         0.0000         4.5823
   4         1.5635         -7.1003         0.0000         7.2705
   5         2.2720         -6.8542         0.0000         7.2209
   6        -0.48860E-01      -3.6622         0.0000         3.6625
   7         3.0782         0.0000         0.0000         3.0782

MAXIMUM ABSOLUTE VALUES
NODE      7          4          0          4
VALUE     3.0782      -7.1003      0.0000      7.2705

```

Are these results what you expected? Note that all the degrees of freedom were constrained to zero at node 1, while UY and UZ was constrained to zero at node 7.

➤ Plot deformation

• In the General Postproc menu, select **Plot Results > Deformed Shape**. The following window will appear.

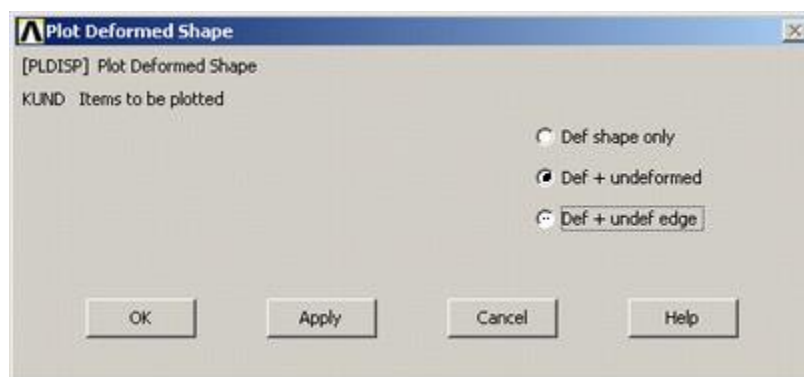

- Select '**Def + undeformed**' and click '**OK**' to view both the deformed and the undeformed object.

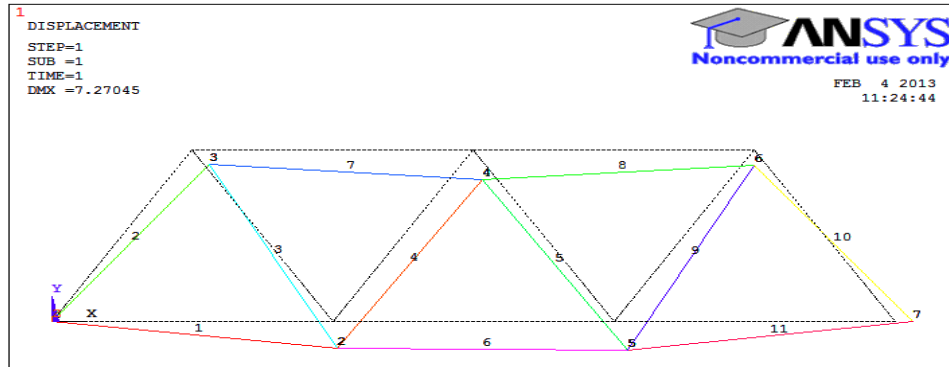

Observe the value of the maximum deflection in the upper left hand corner (DMX=7.27045). One should also observe that the constrained degrees of freedom appear to have a deflection of 0 (as expected!)

- **ANIMATION:** Utility menu>plotcontrols>animate>mode shape>Set No. of frames to create=10,Time delay=0.5>Display type> DOF solution Def+undeformed>OK. Observe

➤ **DEFLECTION:**

From the 'General Postproc' menu select **Plot results > Contour Plot > Nodal Solution**. The following window will appear.

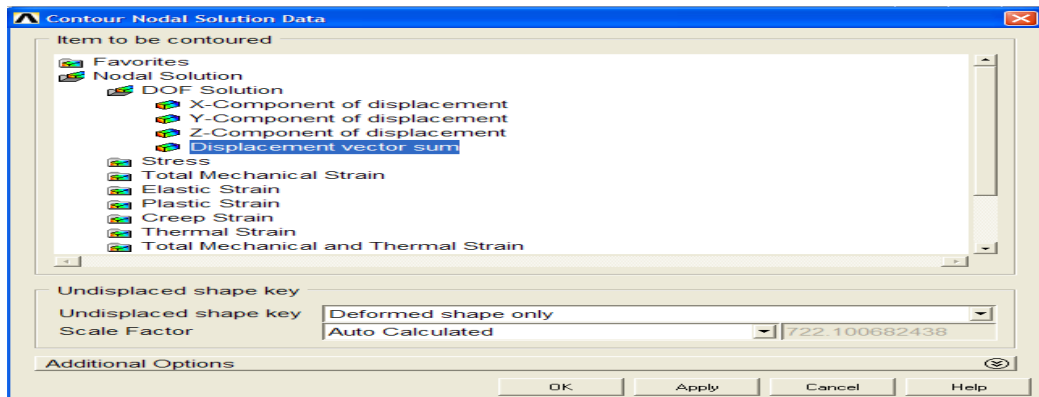

- Select '**DOF solution**' and '**Displacement vector SUM**' as shown in the above window. Leave the other selections as the default values. Click 'OK'.

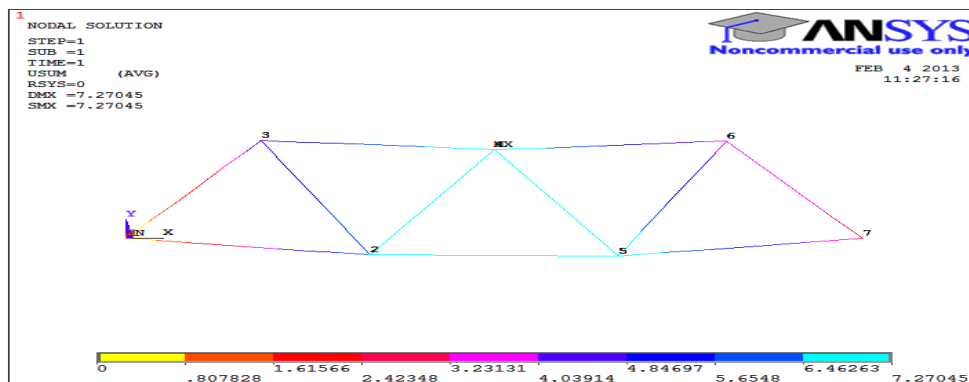

Looking at the scale, you may want to use more useful intervals. From the Utility Menu select **Plot Controls > Style > Contours > Uniform Contours...** Fill in the following window as shown and click 'OK'.

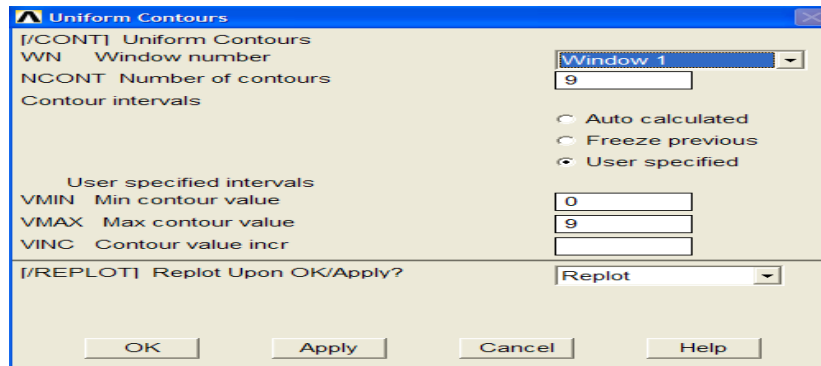

You should obtain the following.

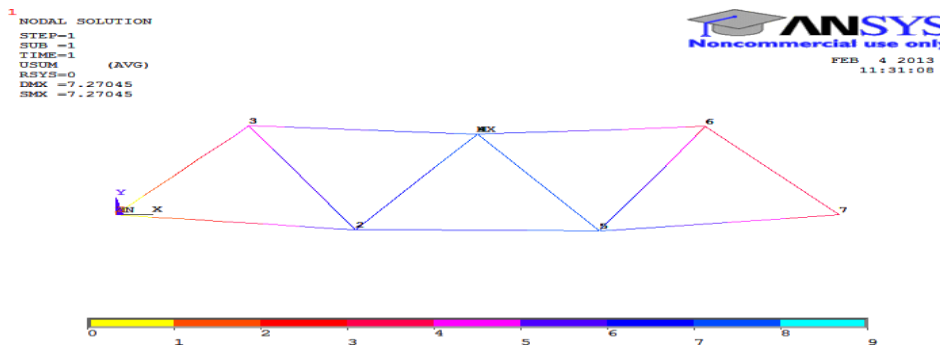

➤ REACTION FORCES

A list of the resulting reaction forces can be obtained.

- From the Main Menu select **General Postproc > List Results > Reaction Solution.**

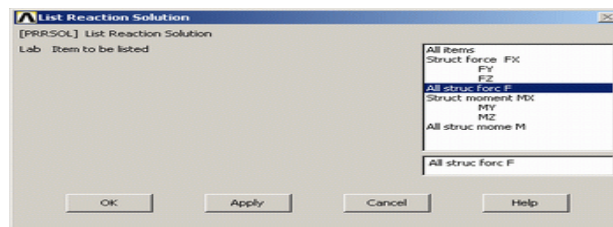

Select '**All struc forc F**' as shown above and click 'OK'

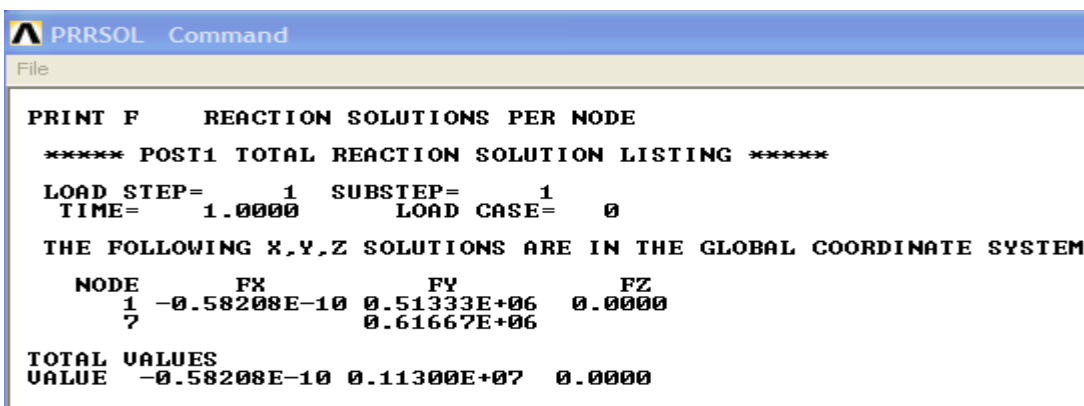

Also try, From the Main Menu select **General Postproc > List Results > Nodal loads**. To get forces at all nodes.

➤ AXIAL STRESS (Sxx) AND FORCE(FORCE)

For line elements (i.e. links, beams, spars, and pipes) you will often need to use the Element Table to gain access to derived data (i.e. stresses, strains). The Element Table is different for each element, therefore, we need to look at the help file for LINK180 (Type help link180 into the Input Line). From Table 5.2 we can see that **Stress** can be obtained through the ETABLE, using the item 'LS,1' and **FORCE** using 'SMISC,1'

- From the General Postprocessor menu select **Element Table > Define Table** . Click on '**Add...**'

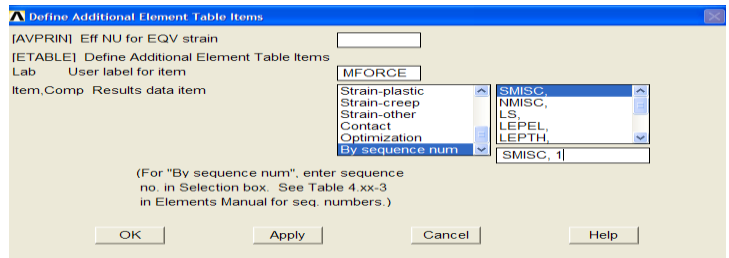
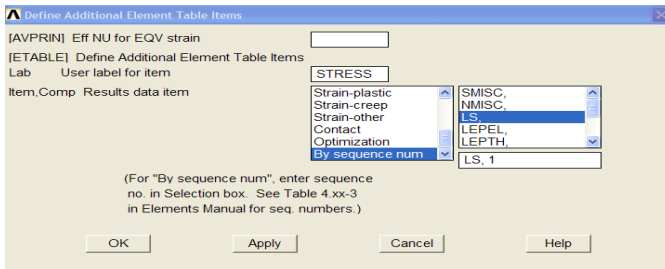

As shown above, enter 'Stress' in the 'Lab' box. This specifies the name of the item you are defining. Next, in the 'Item,Comp' boxes, select 'By sequence number' and 'LS,'. Then enter 1 after LS, in the selection box .

Click on 'Apply' and enter 'FORCE' in the 'Lab' box. This specifies the name of the item you are defining. Next, in the 'Item,Comp' boxes, select 'By sequence number' and 'SMISC,'. Then enter 1 after SMISC, in the selection box and close the 'Element Table Data' window.

List the Stresses

- From the 'Element Table' menu, select 'List Elem Table'
- From the 'List Element Table Data' window which appears ensure '**Stress**' and '**FORCE**' are highlighted
- Click 'OK'

PRINT ELEMENT TABLE ITEMS PER ELEMENT

***** POST1 ELEMENT TABLE LISTING *****

ELEM	STRESS	.FORCE
1	41.880	0.13611E+06
2	-83.117	-0.27013E+06
3	83.117	0.27013E+06
4	-8.3117	-27013.
5	8.3117	27013.
6	87.949	0.28583E+06
7	-83.761	-0.27222E+06
8	-92.137	-0.29944E+06
9	91.429	0.29714E+06
10	-91.429	-0.29714E+06
11	46.068	0.14972E+06
MINIMUM VALUES		
ELEM	8	8
VALUE	-92.137	-0.29944E+06
MAXIMUM VALUES		
ELEM	9	9
VALUE	91.429	0.29714E+06

Plot the Stresses

Element Table > Plot Elem Table

The following window will appear. Ensure that 'Stress' is selected and click 'OK'

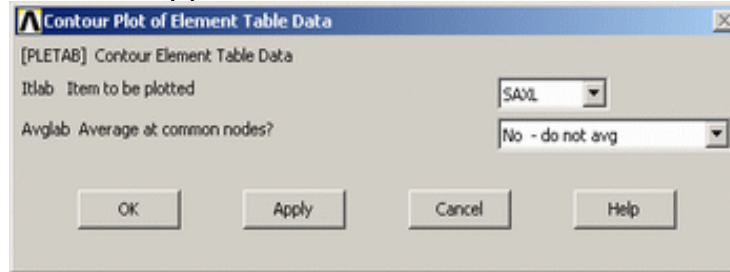

- Because you changed the contour intervals for the Displacement plot to "User Specified" - you need to switch this back to "Auto calculated" to obtain new values for VMIN/VMAX.

Utility Menu > PlotCtrls > Style > Contours > Uniform Contours...

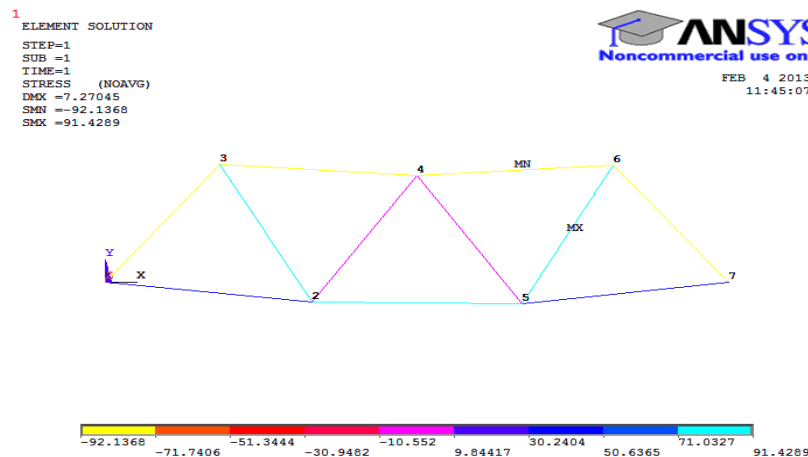

Again, you may wish to select more appropriate intervals for the contour plot

- Carryout plotting member force similarly
- Identify the critically loaded member.
- **Prepare report in the format shown in the next page**

Quitting ANSYS

To quit ANSYS, select '**QUIT**' from the ANSYS Toolbar or **select Utility Menu/File/Exit....** In the dialog box that appears, click on '**Save Everything**' (assuming that you want to) and then click on 'OK'.

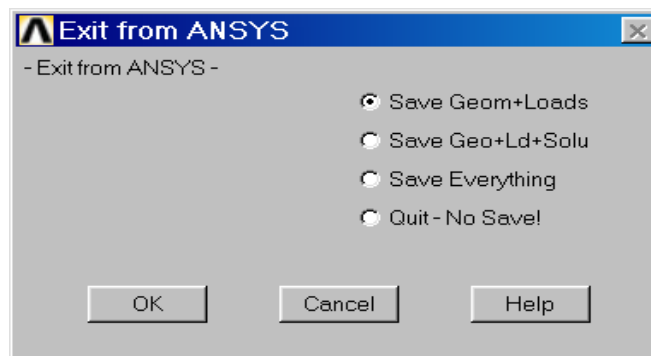

TRUSS- ANALYSIS REPORT

Observation and tabulation

1	Node or key point number
2	Element number(Relevant real constants and material ID's)
3	Displacement boundary conditions to be incorporated
4	Force/moment boundary conditions to be incorporated.
5	Reaction forces
6	Nodal displacements
7	Element stresses
8	Member forces
9	Maximum displacement and location
10	Maximum stress and location(Critical element)

Step1: Name and sketch the element to be used showing its degree of freedom

Ansys 3D-spar element

Sketch	Element Name: Nodes: Degrees of Freedom: Real Constants: Material Properties:.
--------	--

Step2 : Sketch of the given truss structure. Show the origin and XY axes.

Step3: If geometric modeling is done, create keypoint, else node number

Keypoint/node number	x	y

Step4: Tabulate Cross section and material properties

Sl No.	Element No.	Cross section set no. and value of side lengths in mm	Material no. and value of E in MPa
1			

Step 5: Sketch the figure showing Node number and Element number

Step 6: List

a) Displacement boundary conditions to be incorporated			
Node	U_x in mm	U_y in mm	U_z in mm

b) Force/moment boundary conditions to be incorporated			
Node	F_x Newton	F_y Newton	F_z Newton

Step 7 Results

A.: NODAL SOLUTION- DISPLACEMENTS in mm

Node	U _x in mm	U _y in mm	USUM	Remark*

*Highlight node number with maximum and minimum deflection.

B: REACTION SOLUTION: in Newton

NODE	FX	FY	FZ
Total Value			

Check: $\sum F_x =$

$\sum F_y =$

Show reaction on the truss

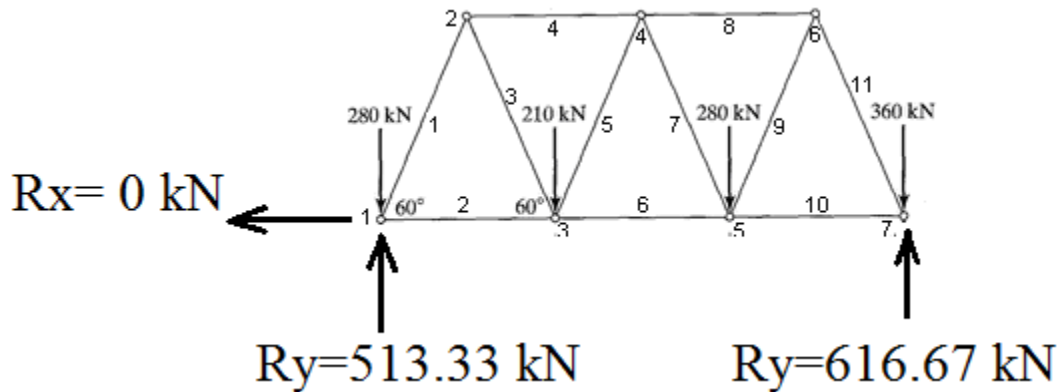

C: ELEMENTAL SOLUTION

Specify: ETABLE Item and sequence number for Stresses **LS , 1**

ETABLE Item and sequence number for Member force **SMISC , 1**

Stresses are in MPa and Forces in N

Stat Element	Current Stress	Current Force
Minimum Values		
Element		
Values		
Maximum Values		
Element		
Values		

- Identify the element with maximum stress:
- Identify the element with maximum member force:
- Estimate the minimum Factor of safety if yield stress is 328 MPa:
- Identify the member/s which is/are yielding if the applied loads are increased 4 times:

Problem 2: Figure shows a truss with an inclined roller support at node 4. The area of cross section of the elements of the truss is 120 sq. mm. The forces acting on the nodes are shown in the figure. It is supported at node 1 by a hinged joint. Node 4 is supported on a roller arrangement and this support allows a freedom of movement at an angle of 30° . Determine the nodal displacement, reactions, and stresses in the truss member shown in figure.

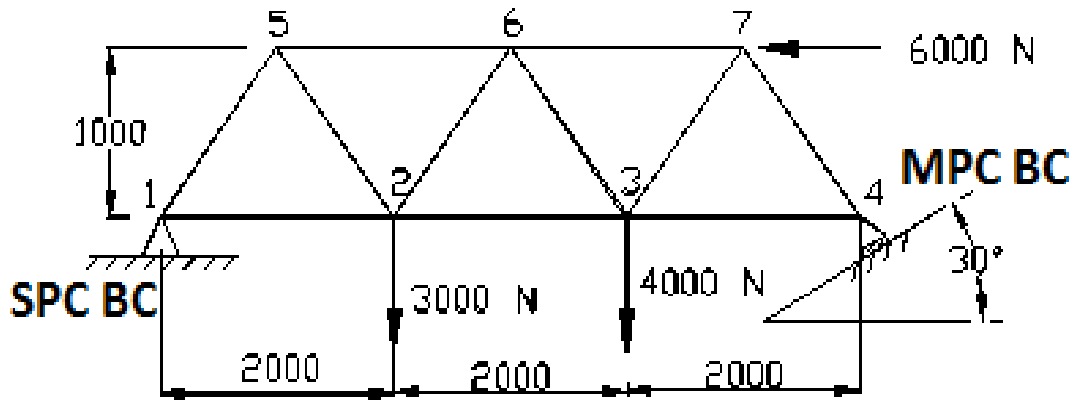

1. File>change job name > Enter "Truss2"
2. Ansys Main Menu > Preferences > structural > Ok
3. Preprocessor > ELEMENT type > Add/edit/delete > add > **Link,3D finit stn 180**> OK
4. Preprocessor > Sections > Link > Add > Add Link section with ID=1, Section Name= 'rect', Area=120 > ok
5. Preprocessor > Material Properties > Material Models > Structural > Linear > Elastic > Isotropic> EX = 2E5, PRXY = 0.3 > OK
6. Preprocessor >Modeling> Create > Nodes > In active CS >Set Node No: = 1, X=0,Y=0, Z=0 > Apply >
 - Set Node No: =2, X= 2000, Y=0, Z=0 > Apply >
 - Set Node No: =3, X= 4000, Y=0, Z=0 > Apply >
 - Set Node No: =4, X= 6000, Y=0, Z=0 > Apply >
 - Set Node No: = 5, X=1000, Y=1000, Z=0 > Apply >
 - Set Node No: =6, X= 3000, Y=1000, Z=0 > Apply>
 - Set Node No: =7, X= 5000, Y=1000, Z=0 > OK

NOTE: For simple line structures, mesh (Nodes and Elements) can be directly created without geometry (without Key points and Lines).

7. Preprocessor > Modeling > Create > elements > Auto Numbered > Thru Nodes > Pick 1 & 2 nodes > Apply > Pick 2 & 3 nodes > Apply > Pick 3 & 4 nodes > Apply > Pick 1 & 5 nodes > Apply > Pick 5 & 6 nodes > Pick 5 & 2 nodes > Apply > Pick 2 & 6 nodes > Pick 6 & 3 nodes > Apply > Pick 6 & 7 nodes > Apply > Pick 3 & 7 nodes > Apply Pick 7 & 4 nodes > OK

8. Preprocessor > Loads > Define Loads > Apply > Structural > Displacement > On Nodes > Pick node 1 > Ok > all DOF > OK
- 9. Preprocessor > Modeling > Create > Nodes > Rotate Cs By Angles > Pick node 4 > OK > Enter THXY(Z-axis)=30 > OK**
10. Preprocessor > Loads > Define Loads > apply > Structural > Displacement > On Nodes > Pick 4 > Ok > UY=0 >
11. Preprocessor > loads > Define Loads > apply > Structural > Force/Moment > On Nodes > Pick 2nd Node > Ok > Select Fy – Apply as = Constant Value , Value of Force/Moment = -3000N > Apply > Pick 3rd Node > Fy = -4000N > Apply > Pick 7th Node > Fx = -6000N > Apply > Ok >
12. Solution > Solve Current LS > OK -Soln Done > Close
13. General Postproc > List Results > Nodal Solution select 'DOF Solution' and 'displacement vector sum' from the lists in the 'List Nodal Solution' window and click 'OK'.
14. General Post Processor > Plot Results > Deformed Shape > Select Def +Undeformed > OK (Blue line indicates deformed shape and white line indicates original shape)
15. Also animate and observe the moment right side roller on the inclined plane
16. General post processor > Element table > Define table > Add > set user label for item = **STRESS**, select item, comp, results data item = by sequence number- select **LS, 1** (Type 1 after selecting LS) > OK > set user label for item = **FORCE**, select item, comp, results data item = by sequence number- select **SMISC,1** > Close
17. General Post Processor > Element Table > List Element Table > Select **STRESS & FORCE** > OK > Note the stress & Member Force in elements
18. General Post Processor > Plot Results > Contour Plots –Line Element Results > Select LabI=FORCE and LABJ= FORCE > Ok (see the forcess in the members)
19. File > Save as > Select the user directory > Truss2 > OK

S.N	Node Nos.	Displacement In mm			Reactions / Forces in N			Element No.	Stresses MPa	FORCE N
		x	y	Z	Fx	Fy	Fz			
1								1.		
2								2.		
3								3.		
4								4.		
5								5.		
6								6.		
7								7.		
								8.		
								9.		
								10.		
								11.		

Problem 3: Consider a two dimensional structure shown in figure 3a. The Geometry and loading are symmetrical about the centerline. Determine nodal reactions and reactions as well as element stress and forces. $A=100 \text{ mm}^2$, Aluminum= $70 \times 10^3 \text{ N/mm}^2$, Steel = $200 \times 10^3 \text{ N/mm}^2$
Use symmetry conditions (ref.fig. 3b)

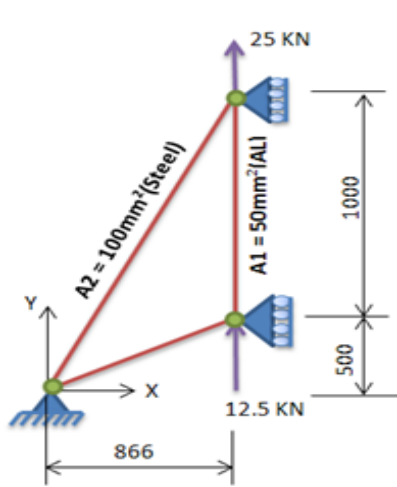

3b-Symmetric model

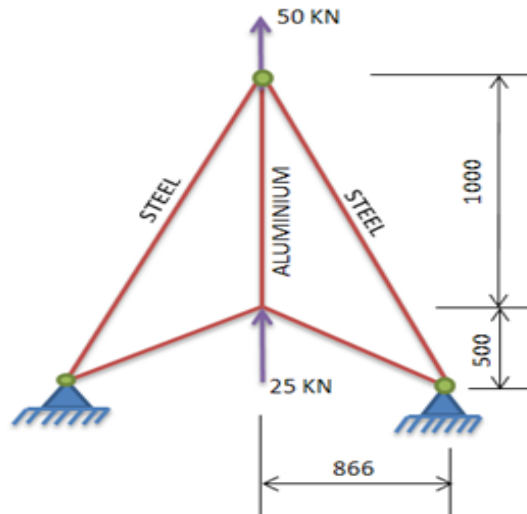

3a-Full Model

- Ansys Main Menu > Preprocessor > Sections > Link > Add > Add Link section with ID=1, Section Name= 'area1', Area=50 > Apply > Add Link section with ID= 2, Section Name= 'area2', Area=100 > ok
- Ansys Main Menu > Preprocessor > Material Properties > Material Models > Structural > Linear > Elastic > Isotropic > EX= 70E3, PRXY = 0.3 > OK > Material > New model > Define Material ID=2 OK > Isotropic > EX= 200E3, PRXY = 0.3 > OK > Close

For Full Model:

Sl No	Node Nos.	Displacement In mm			Reactions / Forces in N			Element No.	Stresses MPa	Force N
		x	y	Z	Fx	Fy	Fz			
1										
2										
3										
4										

For Symmetry Model:

Sl No	Node Nos.	Displacement In mm			Reactions / Forces in N			Element No.	Stresses MPa	Force N
		x	y	z	Fx	Fy	Fz			
1										
2										
3										

Prioritize case a) or case b) by identifying

Sl. No.	No. of elements used	Total no. of DOFs in the mesh	The size of global stiffness matrix	Size of modified stiffness matrix	
				Elimination approach	Penalty approach
Case a)					
Case b)					
Conclusion					

Problem 4: A three bar steel truss is shown in figure. All bars have the same area of cross section of 100 mm^2 . If the temperature of bar 1-2 is increased by 50°C . Find the displacement of joint and the axial force in the three bars. Young's modulus = 200 GPa , $\alpha = 11.7 \times 10^{-6} \text{ per } ^\circ\text{C}$. $L = 1000 \text{ mm}$

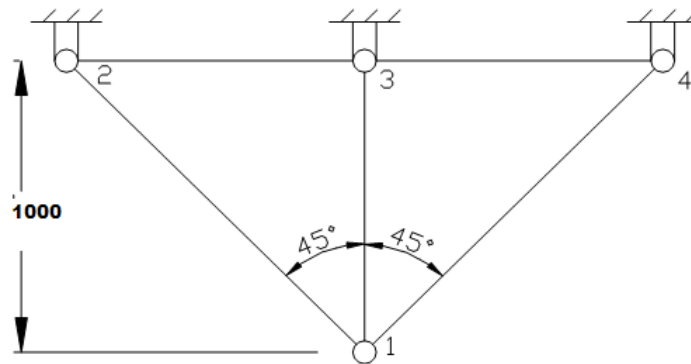

Hint:

- Ansys Main Menu > Preprocessor > Material Properties > Material Models > Structural > Linear > Elastic > Isotropic > Specify Material No:= 1 > OK > Thermal expansion > secant coefficient > Isotropic > ALPX = 11.7×10^{-6} (and reference temperature if given, here it is not given) > ok
- Ansys Main Menu > Solution > loads Define Loads > apply > Structural > temp > on elements > pick the element at bar 1-2 > ok > Enter VAL1 = rise in temp + reference temperature if given (Enter only VAL1 for a uniform body load across the element) > ok

Sl No	Node Nos.	Displacement In mm			Reaction Forces in N			Element No.	Stress MPa
		x	y	Z	Fx	Fy	Fz		
1								1	
2								2	
3								3	
4									

NOTE: elements between nodes 2-3 and 3-4 are not required.

Problem 5: Consider the 4 Bar Truss Shown In fig. and solve the problem for displacements stresses and Reaction Forces.

$A = 100 \text{ mm}^2$, Young's modulus= $2 \times 10^5 \text{ N/mm}^2$

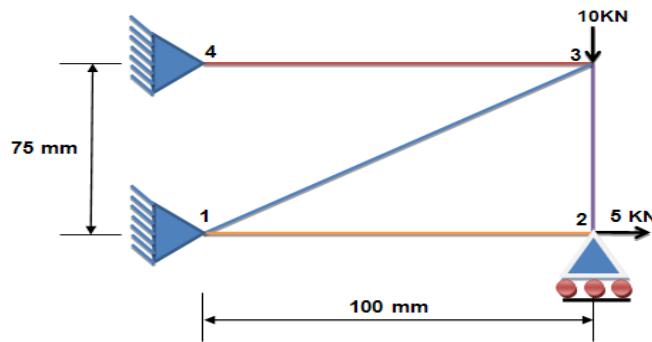

Results: NODAL SOLUTION- DISPLACEMENTS:

Node No.	Ux	Uy	Uz	USUM
1				
2				
3				
4				

Results: REACTION SOLUTION:

Node No.	Fx	Fy	Fz
1			
2			
3			
4			

Check: $\sum F_x =$

$\sum F_y =$

Results: ELEMENTAL SOLUTION- STRESSES:

Element No.	Stress	Force
1		
2		
3		
4		

Problem 6: Find the forces, stresses on each member of the following truss structure.

Data; $A=100\text{mm}^2$ $\nu= 0.3$

Young's modulus= $2e5 \text{ N/mm}^2$.

Also find displacement field.

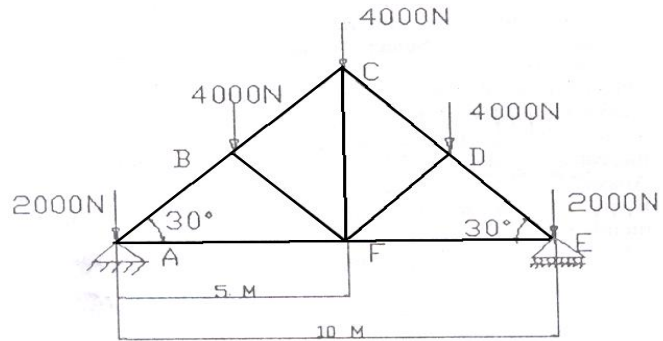

RESULTS:

SI No	Node Nos.	Displacement In mm			Reactions / Forces in N			Element No.	Stresses	MFORX N
		x	y	Z	Fx	Fy	Fz		MPa	
1								1.		
2								2.		
3								3.		
4								4.		
5								5.		
6								6.		
								7.		
								8.		
								9.		

Problem 7: For the pin-jointed configuration shown in figure.

a) Calculate the reaction forces.

$E = 200\text{GPa}$

b) Nodal displacements

c) Element stresses

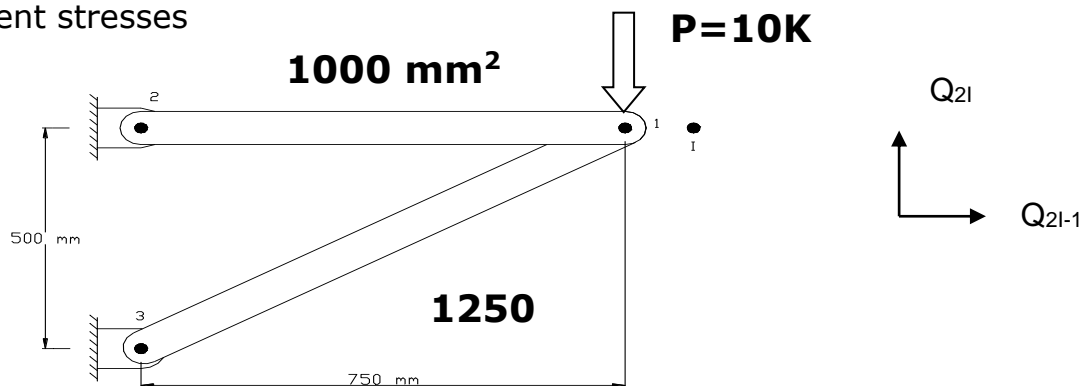

SI No	Node Nos.	Displacement In mm		Reactions / Forces in N		Element No.	Stresses	MFORCE N
		x	y	Fx	Fy		MPa	
1						1		
2						2		
3						3		
4						4		
5						5		
						6		

Problem 8: For the two-bar truss shown in figure, determine the reaction forces, nodal displacements, and element stresses. If Yield stress is 400MPa, comment on the safety of the truss structure.

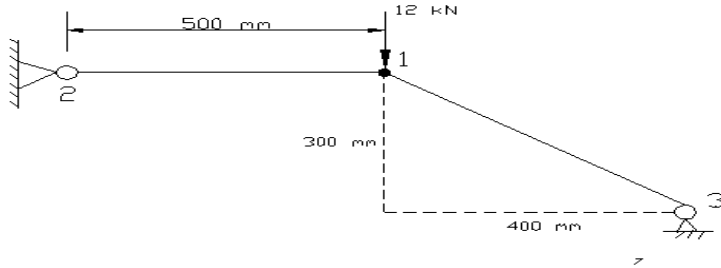

Young's modulus = 70 GPa
Area = 200 mm²

For both members

Sl No	Node Nos.	Displacement In mm		Reactions / Forces in N		Element No.	Stresses MPa	Mforce N
		x	y	Fx	Fy			
1								
2								
3								

Problem 9: Determine the force in each member of the following truss. indicate if the member is in tension or compression. The cross-sectional area of each member is m, the Young's modulus is 200x10⁹ N/m² and Poisson ratio is 0.3.

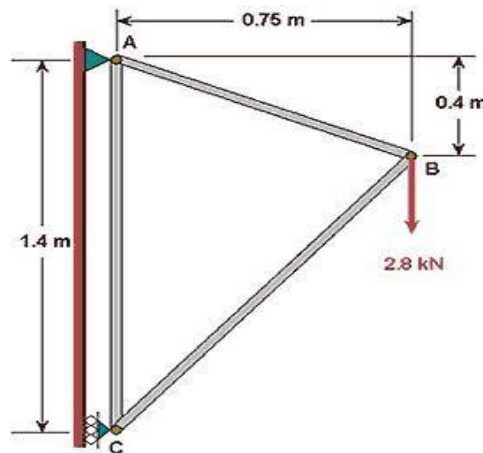

Sl No	Node Nos.	Displacement In mm		Reactions / Forces in N		Element No.	Stresses MPa	Mforce N
		x	y	Fx	Fy			
1								
2								
3								

Problem 10: For the truss shown in figure, determine the reaction forces, nodal displacements, and element stresses.

$A = 100 \text{ mm}^2$,
Young's modulus
 $= 200 \text{ GPa}$

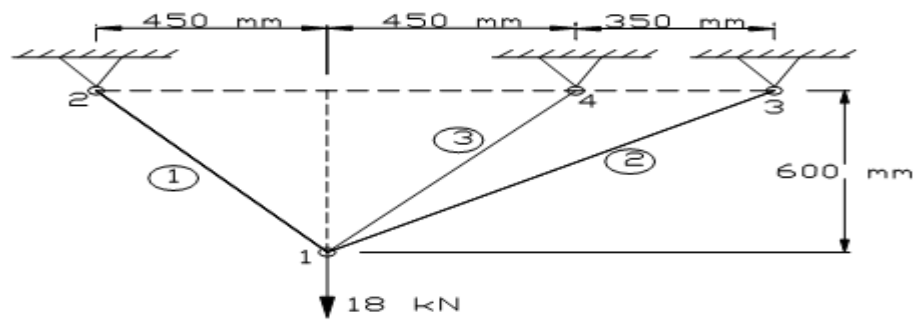

SI No	Node Nos.	Displacement In mm		Reactions / Forces in N		Element No.	Stresses MPa
		x	y	Fx	Fy		
1						1	
2						2	
3						3	
4							

Problem 11: Determine the force in each member of the following truss using ANSYS. Indicate if the member is in tension or compression the cross-sectional area of each member is 0.02 m^2 , Young's modulus is $200 \times 10^9 \text{ N/m}^2$ and Poisson's ratio is 0.3.

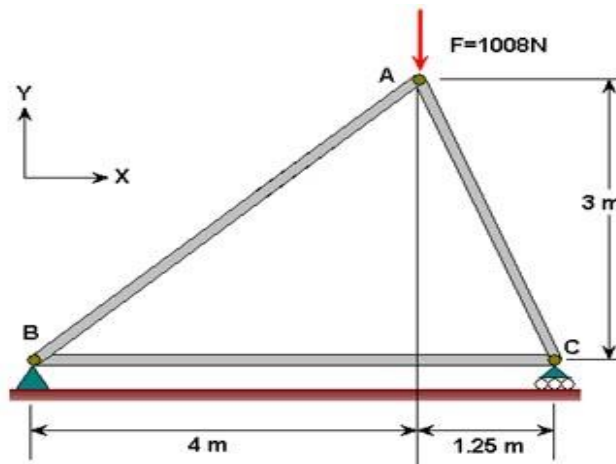

SI No	Node Nos.	Displacement In mm		Reactions / Forces in N		Element No.	Stresses MPa	Force N
		x	y	Fx	Fy			
1								
2								
3								

Problem 12: Figure shows a truss loaded with 500 N at node 2. All horizontal members have an area of 100 sq. mm and inclined members an area of 80 sq. mm. E for element 3 = 80 Gpa, other elements $E = 210$ Gpa. Determine the nodal displacement, reactions, and stresses in the truss member.

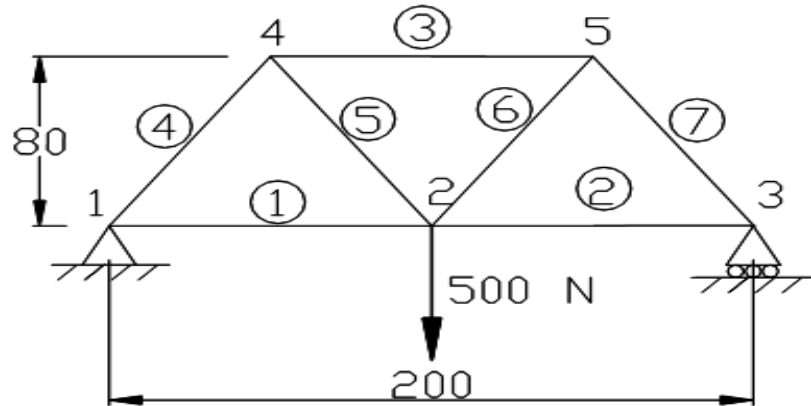

SI No	Node Nos.	Displacement In mm		Reactions / Forces in N		Element No.	Stresses MPa	Force N
		x	y	Fx	Fy			
1						1.		
2						2.		
3						3.		
4						4.		
5						5.		
6						6.		
7						7.		

PROBLEM 13: For the truss shown in figure, determine the reaction forces, nodal displacements, and element stresses. Young's modulus = 208GPa, $A=1000 \text{ mm}^2$

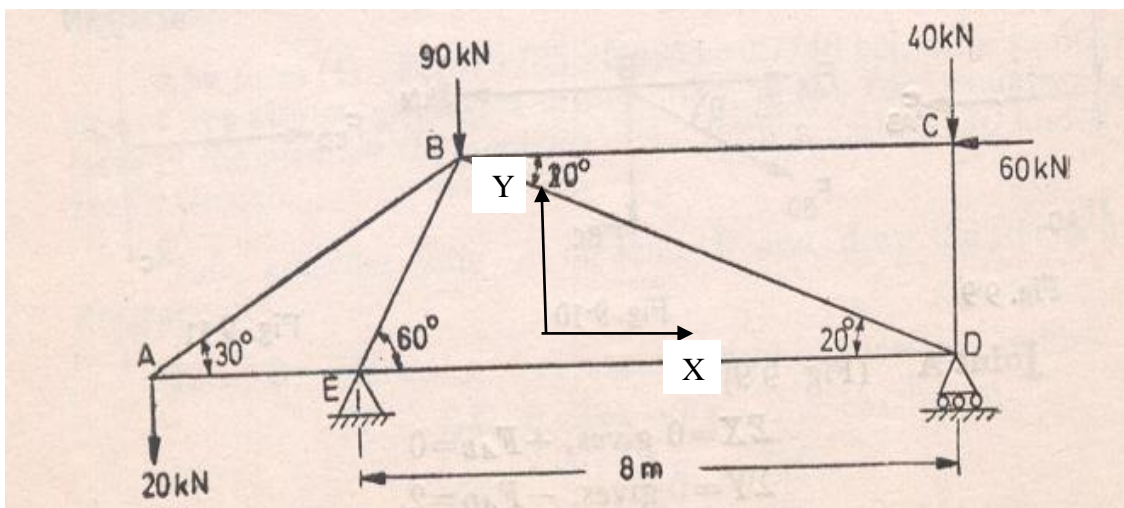

SI No	Node Nos.	Coordinates		Displacement In mm		Reactions / Forces in N		Element No.	Stresses MPa
		X	Y	U _x	U _y	F _x	F _y		
1									
2									
3									
4									
5									
6									
7									

PROBLEM 14: Find the deflections, nodal reactions, element stresses for the truss shown. $A = 5000 \text{ mm}^2$, Young's modulus = 200 GPa

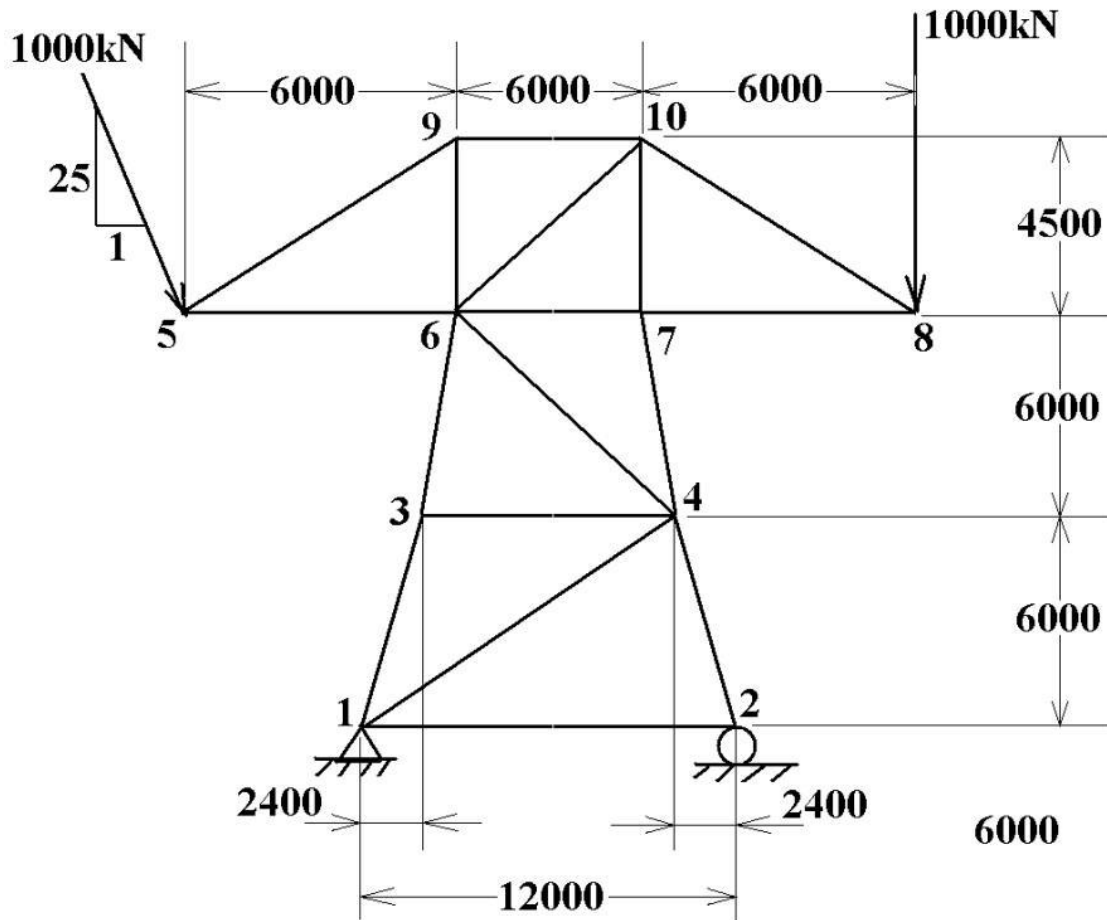

SI No	Node Nos.	Displacement In mm		Reactions / Forces in N		Element No.	Stresses MPa	Force N
		x	y	Fx	Fy			
1						1.		
2						2.		
3						3.		
4						4.		
5						5.		
6						6.		
7						7.		
8						8.		
9						9.		
10						10.		
						11.		
						12.		
						13.		
						14.		
						15.		
						16.		
						17.		

Chapter 6: PROBLEMS ON AXIAL LOADING

Problem 15: Find Nodal Displacements Stresses and reaction forces for the following problem using Link Element. $A_{AL} = 2400 \text{ mm}^2$, Young's modulus $= 70 \times 10^3 \text{ N/mm}^2$, $A_{ST} = 600 \text{ mm}^2$, Young's modulus $= 200 \times 10^3 \text{ N/mm}^2$

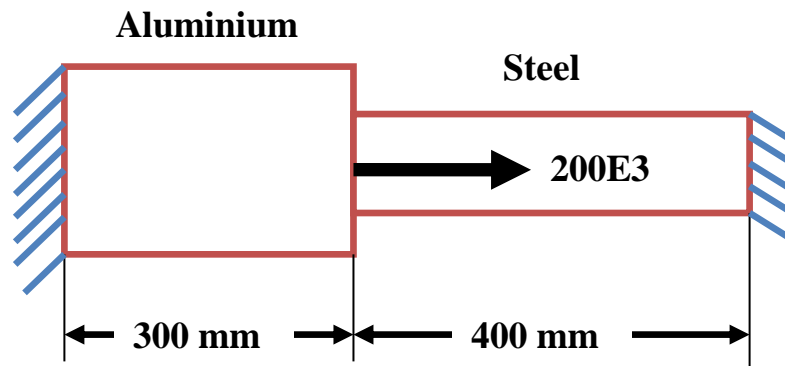

SOLUTION:

1. File > change job name > Enter "axial15"
2. Ansys Main Menu > Preferences > structural > Ok
3. Ansys Main Menu > Preprocessor > ELEMENT type > Add/edit/delete > add > **Link,3D finit stn 180** > OK
4. Ansys Main Menu > Preprocessor > Sections > Link > Add > Add Link section with ID=1, Section Name= 'area1', Area=2400 > Apply > Add Link section with ID= 2, Section Name= 'area2', Area=600 > ok.
5. Ansys Main Menu > Preprocessor > Material Properties > Material Models > Structural > Linear > Elastic > Isotropic > Specify Material No: = 1 > OK > Young's modulus= 70E3, Poisson's ratio = 0.3 > apply > Specify Material No: = 2 > OK > Young's modulus= 200E3, Poisson's ratio= 0.3 > apply > OK
6. Ansys Main Menu > Preprocessor > Modeling > Create > Nodes > In active CS > Set Node No: = 1, X=0, Y=0, Z=0 > Apply > Set Node No: =2, X= 300, Y=0, Z=0 > Apply > Set Node No: = 3, X=700, Y=0, Z=0 > OK
7. Ansys Main Menu > Preprocessor > Modeling > Create(Check Element attributes) > elements > Auto numbered > Thru Nodes > Pick 1 & 2 nodes > OK
8. Ansys Main Menu > Preprocessor > Modeling > Create > elements > Elements Attributes > Set Element Type No 1 LINK1, Set Material No. 2, Set section with ID: = 2 > OK
9. Ansys Main Menu > Preprocessor > Modeling > Create > elements > Thru Nodes > Pick nodes 2 & 3 node > OK
Utility menu > plot controls > style > size and shape > Display of element based on real constant **ON** > ok. To visualize the stepped bar
10. Ansys Main Menu > Preprocessor > Loads > Define Loads > apply > Structural Displacement > On Nodes > Pick 1 and 3 > Ok > all DOF > Ok
11. Ansys Main Menu > Preprocessor > loads > Define Loads > apply > Structural > Force/Moment > On Nodes > Pick 2nd Node > Ok > Select FX

- Apply as Constant Value and Select Value of Force/Moment = 200e3 > OK
- 12. Ansys Main Menu > solution > Solve Current LS > OK Soln Done > Close
- 13. Ansys main menu > general post processor > Element table > Define table > Add > set user label for item = **STRESS**, select item, comp, results data item = by sequence number- select **LS,1**(Type 1 after selecting LS) > OK > set user label for item = **Force**, select item, comp, results data item = by sequence number- select **SMISC,1**>Close
- 14. Ansys Main Menu > General Post Processor > Element Table > List Element Table > Select STRESS and force> OK > Note the stress and force in each element
- 15. Ansys Main Menu > General Post Processor > List Results > Nodal Solution > Dof solution > x component of DOFs > Ok (Note the Nodal displacement results)
- 16. Ansys Main Menu > General Post Processor > List Results > Reaction Solutions > Select all items > OK > (Note the reaction solution)
- 17. Ansys Main Menu > General Post Processor > Plot Results > Deformed Shape > Select Def +Unreformed > OK (Blue line indicates deformed shape and white line indicates original shape)
- 18. Ansys Main Menu > General Post Processor > Plot Results > Contour Plots -Line Element Results > Select Lab1=stress > Ok (see the stress in the members)
- 19. File > Save as > Select the user directory > Axial2 > OK

Results: NODAL SOLUTION- DISPLACEMENTS:

Node No.	Ux (mm)	Uy (mm)	Uz (mm)
1			
2			
3			

Results: ELEMENTAL SOLUTION- STRESSES:

Element No.	Stress(MPa)	Force (N)
1		
2		

Results: REACTION SOLUTION:

Node No.	Fx	Fy	Fz
1			
2			

Check $\sum F_x =$

$\sum F_y =$

Note: Compare Solutions with SOM

Problem 16: case a) For the simple bar shown in the figure determine the displacement strain, stress caused due to self-weight given length of the bar is 0.5m , cross-section area of the bar is 0.1m^2 , $\rho = 7848\text{ kg/m}^3$ and Young's Modulus $2 \times 10^{11}\text{ N/m}^2$

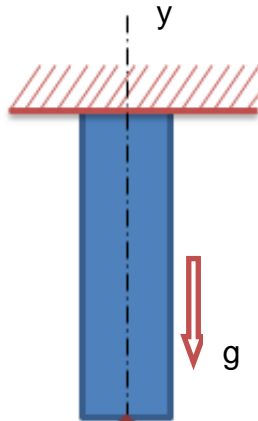

1. File>change job name > Enter "**axial16**"
2. Ansys Main Menu > Preferences > structural > Ok
3. Ansys Main Menu > Preprocessor > ELEMENT type > Add/edit/delete > add > **Link,3D finit stn 180**> OK
4. Ansys Main Menu > Preprocessor > Sections > Link > Add > Add Link section with ID=1, Section Name= 'area1', Area=0.1 > ok
5. Ansys Main Menu > Preprocessor > Material Properties > Material Models > Structural > Linear > Elastic > Isotropic> Specify Material No:= 1> OK> Youngs modulus= $2E11$, Poisson's ratio Minor= 0.3 > OK>density>7848>ok
6. Ansys Main Menu > Preprocessor >Modeling> Create > key point > In active CS > Set Key point No: = 1, X=0,Y=0, Z=0 > Apply > Set Key point NO: =2, X= 0, Y=-0.5, Z=0 > OK
7. Ansys Main Menu > Preprocessor >Modeling> Create > line > cursor pick> key points 1and 2 >Ok
8. Ansys Main Menu > Preprocessor > Meshing >Size control > Manual Size >Lines >Picked Line >NDIV=10 > OK
9. Ansys Main Menu > Preprocessor > Meshing>Mesh>Pickline> OK
10. Ansys Main Menu > Solver > loads> Define Loads > apply > Structural Displacement > On keypoint > Pick 1 > Ok > all DoF > Ok
11. Ansys Main Menu > Solver >loads> Define Loads > apply > Structural > Inertia >Gravity>Global >ACELY=9.81>OK
12. Ansys Main Menu > solution >Solve Current LS >OK> Soln Done > Close
13. Ansys main menu > general post processor > Element table > Define table > Add > set user label for item = **STRESS**, select item, comp, results data item = by sequence number- select **LS,1**(Type 1 after selecting LS) > OK > set user label for item = **Force**, select item, comp, results data item = by sequence number- select **SMISC,1**>Close

14. Ansys Main Menu > General Post Processor > Element Table > List Element Table > Select STRESS and force > OK > Note the stress and force in each element
15. Ansys Main Menu > General Post Processor > List Results > Nodal Solution > Dof solution > x component of DOFs > Ok (Note the Nodal displacement results)
16. Ansys Main Menu > General Post Processor > List Results > Reaction Solutions > Select all items > OK > (Note the reaction solution)
17. Ansys Main Menu > General Post Processor > Plot Results > Deformed Shape > Select Def +Unreformed > OK (Blue line indicates deformed shape and white line indicates original shape)
18. Ansys Main Menu > General Post Processor > Plot Results > Contour Plots -Line Element Results > Select Lab1=**stress** > Ok (see the stress in the members)
19. File > Save as > Select the user directory > Axial 16 > OK

Results: SOLUTION- DISPLACEMENTS: Element solution

Node No.	Ux (mm)	Uy (mm)	Uz (mm)	Element	Stress (MPa)	Force N
1.						
2.						
3.						
4.						
5.						
6.						
7.						
8.						
9.						
10.						
11.						

Results: REACTION SOLUTION:

Node No.	Fx	Fy
1		

Check $\sum F_x =$

$\sum F_y =$

Compare with SOM Solutions

$$u_x = \frac{\rho g l x}{2E}$$

$$u_{\max} = \frac{\rho g l^2}{2E} =$$

Problem 16: case b) Solve the same problem by putting total weight at free end and Compare:

Problem 17: Model the figure with 1D bar elements and find tip displacement. Carry out convergence study (H - convergence) by increasing the number of elements (1,2,4,8) and plot graph of displacement Vs number of elements and Compare with theoretical value.

$P = 10\text{kN}$, $d_1 = 40\text{ mm}$, $d_2 = 20\text{ mm}$, $l = 300\text{ mm}$,
 Young's modulus = 20 Gpa

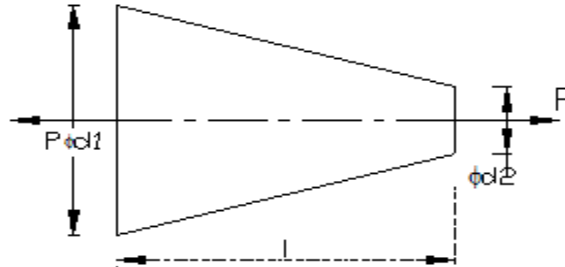

Note: For Taper rod under axial loading, **Theoretical deflection**
 $\delta = 4Pl / (\pi E d_1 d_2)$

STEP 1 One element

$RC = \pi * 30^2 / 4 = 706.85\text{ mm}^2$, $L_e = 300\text{ mm}$

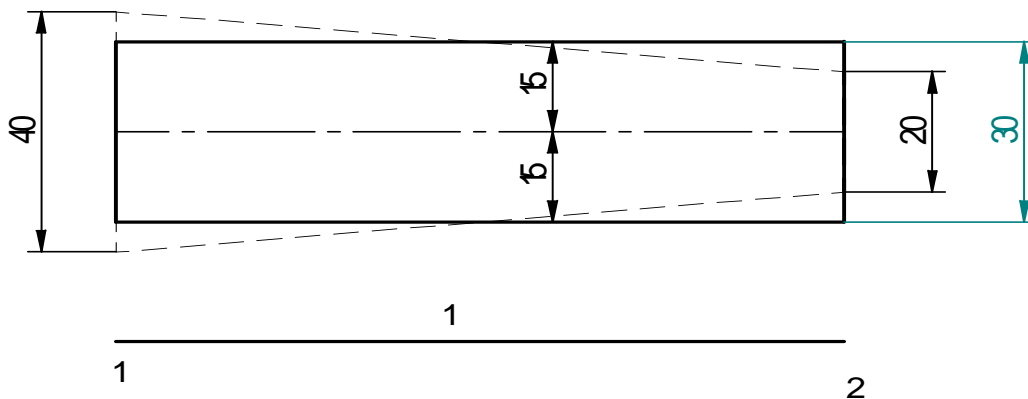

Displacements In mm

NODE	UX	UY	UZ	USUM
1	0.0000	0.0000	0.0000	0.0000
2	0.21221	0.0000	0.0000	0.21221

MAXIMUM ABSOLUTE VALUES NODE 2 0.21221

ELEMENT STRESSES (LS,1)

ELEM	STRESS (MPa)
1	14.147

STEP 2 Two elements

RC-1 = $\pi * 35^2/4 = 962.113 \text{ mm}^2$, $L_e = 150 \text{ mm}$

RC-2 = $\pi * 25^2/4 = 490.873 \text{ mm}^2$, $L_e = 150 \text{ mm}$

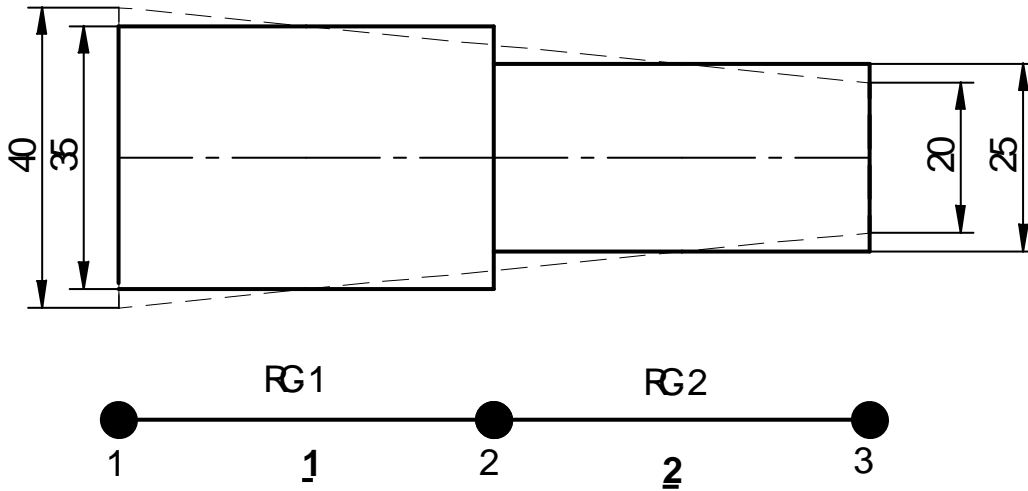

Nodes and coordinates

NODE	X	Y
1	0.0000	0.0000
2	150.00	0.0000
3	300.00	0.0000

Connectivity table

ELEM	NODES	AREA mm ²	MAT
1	1 2	962.113	1
2	2 3	490.873	1

Displacements in mm

NODE	UX	UY	UZ	USUM
1	0.0000	0.0000	0.0000	0.0000
2	0.77953E-01	0.0000	0.0000	0.77953E-01
3	0.23074	0.0000	0.0000	0.23074

MAXIMUM ABSOLUTE VALUES

NODE3 0.23074

ELEMENT STRESSES (LS 1) in MPa

ELEM STRESS

1	10.394
2	20.372

STEP 3 Four elements

RC-1 = $\pi * 37.5^2/4 = 1105.64 \text{ mm}^2$, $L_e = 75 \text{ mm}$

RC-2 = $\pi * 32.5^2/4 = 829.577 \text{ mm}^2$, $L_e = 75 \text{ mm}$

RC-3 = $\pi * 27.5^2/4 = 593.95 \text{ mm}^2$, $L_e = 75 \text{ mm}$

RC-4 = $\pi * 22.5^2/4 = 397.6 \text{ mm}^2$, $L_e = 75 \text{ mm}$

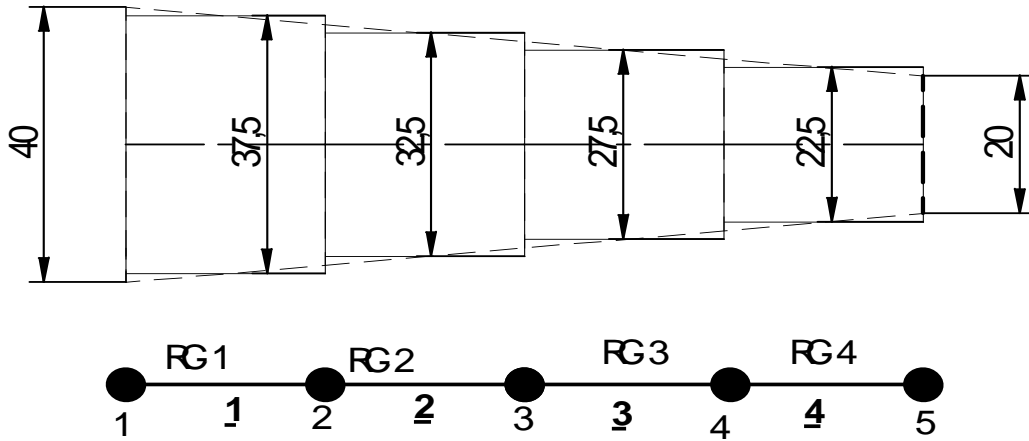

Nodes and coordinates

NODE	X	Y	Z	THXY	THYZ	THZX
1	0.0000	0.0000	0.0000	0.00	0.00	0.00
2	75.000	0.0000	0.0000	0.00	0.00	0.00
3	150.00	0.0000	0.0000	0.00	0.00	0.00
4	225.00	0.0000	0.0000	0.00	0.00	0.00
5	300.00	0.0000	0.0000	0.00	0.00	0.00

LIST ALL SELECTED ELEMENTS.

ELEM	NODES	AREA mm ²	MAT
1	1 2	1105.63	1
2	2 3	829.566	1
3	3 4	593.957	1
4	4 5	397.61	1

Displacements In mm

NODE	UX	UY	UZ	USUM
1	0.0000	0.0000	0.0000	0.0000
2	0.33917E-01	0.0000	0.0000	0.33917E-01
3	0.79121E-01	0.0000	0.0000	0.79121E-01
4	0.14226	0.0000	0.0000	0.14226
5	0.23657	0.0000	0.0000	0.23657

ELEMENT STRESSES (LS 1)in MPa

STAT	CURRENT
ELEM	STRESS
1	9.0445
2	12.054
3	16.836
4	25.151

CONVERGENCE STUDIES-H CONVERGENCE

SL.NO	NUMBER OF ELEMNTS	TIP DISPLCEMENT(ANSYS) IN mm	TIP DISPLCEMENT EXACT FROM SOM In mm	Stress at small(Free) end(ANSYS) MPa	Stress at small(Free) end MPa
1	1	0.21221	$\delta_{\text{exact}} = \frac{4PL}{\pi E d_1 d_2} = 0.2387314$	14.147	$\sigma = \frac{4p}{(\pi d_2^2)} = 31.85$
2	2	0.23074		20.372	
3	4	0.23657		25.151	

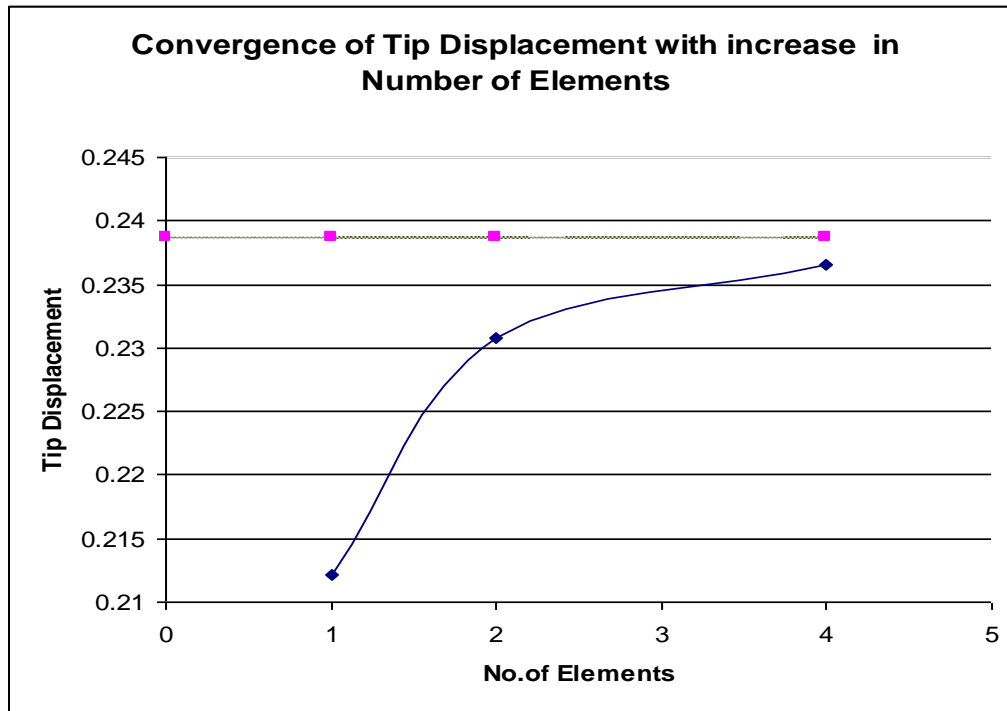

Graph of H Convergence

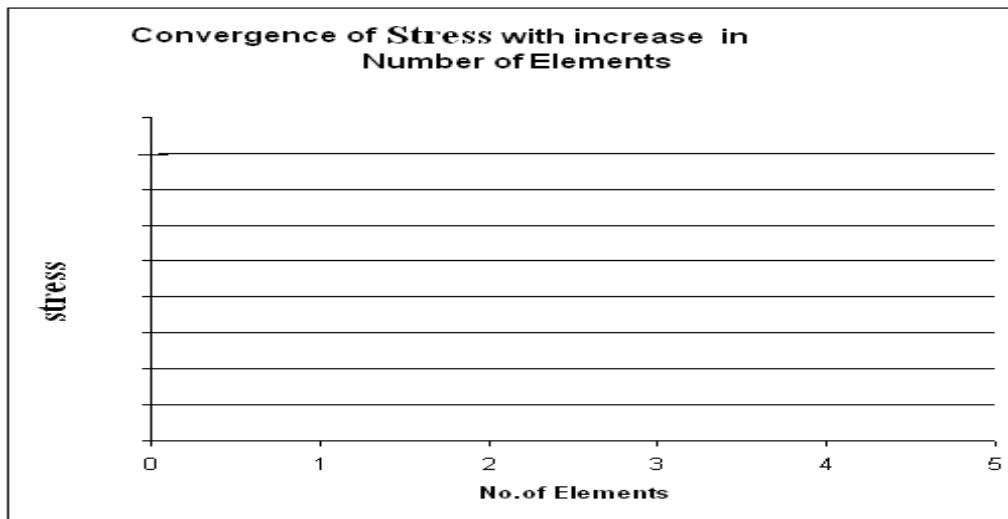

Graph of Convergence of tip stress with increase in number of elements

Question: Check whether displacement or stress converges faster. What are its implications?

Problem18: Model the figure with 1D bar elements and find tip displacement carry out convergence study (H - convergence) by increasing the number of elements (1,2,4,8) and plot graph of V_{tip} displacement Vs number of elements and Compare with theoretical value. $P = 15kN$, $t = 15\text{ mm}$, $d1 = 100\text{ mm}$, $d2 = 40\text{ mm}$, $l = 300\text{mm}$, Young's modulus $E = 200\text{ Gpa}$, poisson's ratio = 0.3

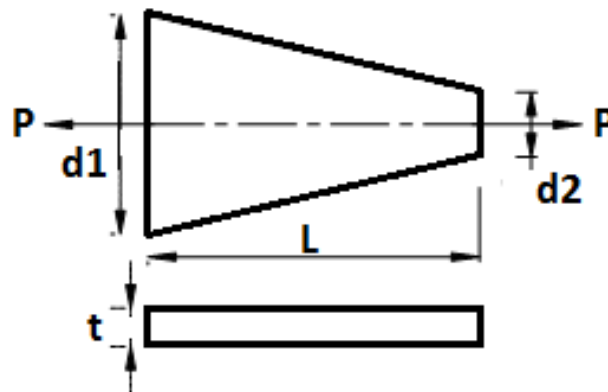

Theoretical deflection $\delta = \{Pl \log_e(d1/d2)\} / \{E t (d1-d2)\}$
ELEMENT TYPE =

No. of elements: One

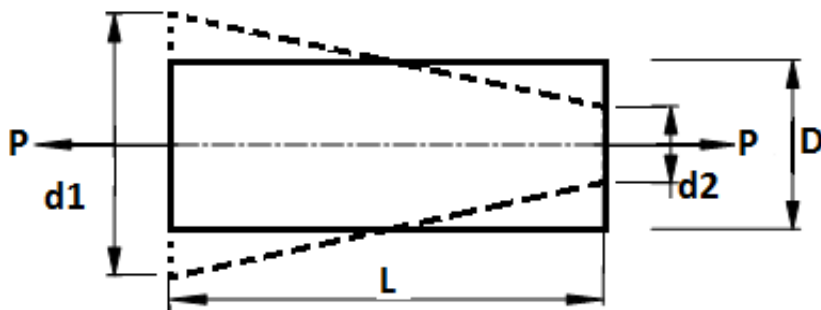

$$D1 = (d1+d2) / 2$$

Displacement u_x at node 2 =

$$A1 = D1.t =$$

No. of elements : Two

Discretization (connectivity) and material properties

Sl. No.	Element No.	Node No.	Length mm	C/S area	E (Gpa)
1		1-2			
2		2-3			

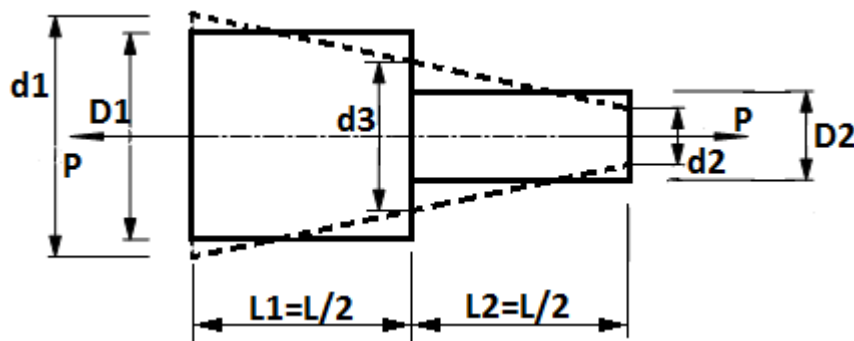

$$d3 = (d1+d2) / 2$$

$$D1 = (d1+d3) / 2$$

$$D2 = (d3+d2) / 2$$

Displacement u_x at node 3 =

No. of elements : Four

Discretisation (connectivity) and material properties

Sl. No.	Element No.	Node No.	Length	C/S area
1	1	1-2		
2	2	2-3		
3	3	3-4		
4	4	4-5		

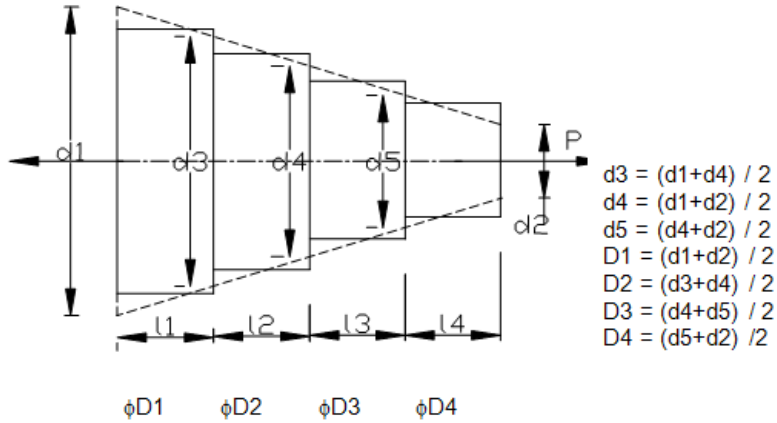

Displacement u_x at node 5 =

No. of elements: eight

Discretization (connectivity) and material properties

Sl. No.	Element No.	Node No.	d1 mm	d2 mm	Length mm	C/S	
						D, mm	A, mm ²
1	1	1-2					
2	2	2-3					
3	3	3-4					
4	4	4-5					
5	5	5-6					
6	6	6-7					
7	7	7-8					
8	8	8-9					

Answer - Tip deflection

Theoretical	No. of Finite Elements			
	1	2	4	8

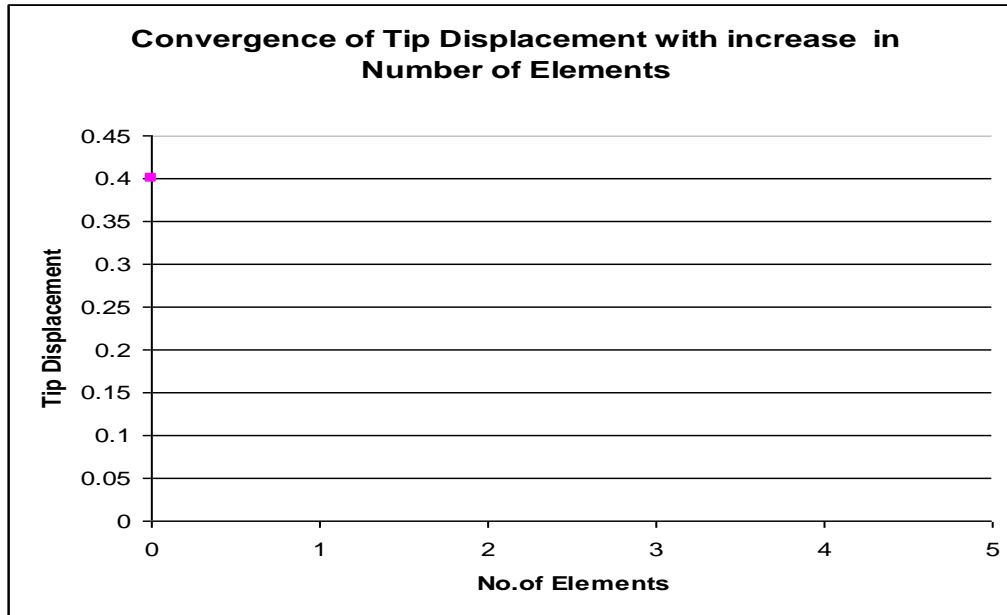

Graph of H Convergence

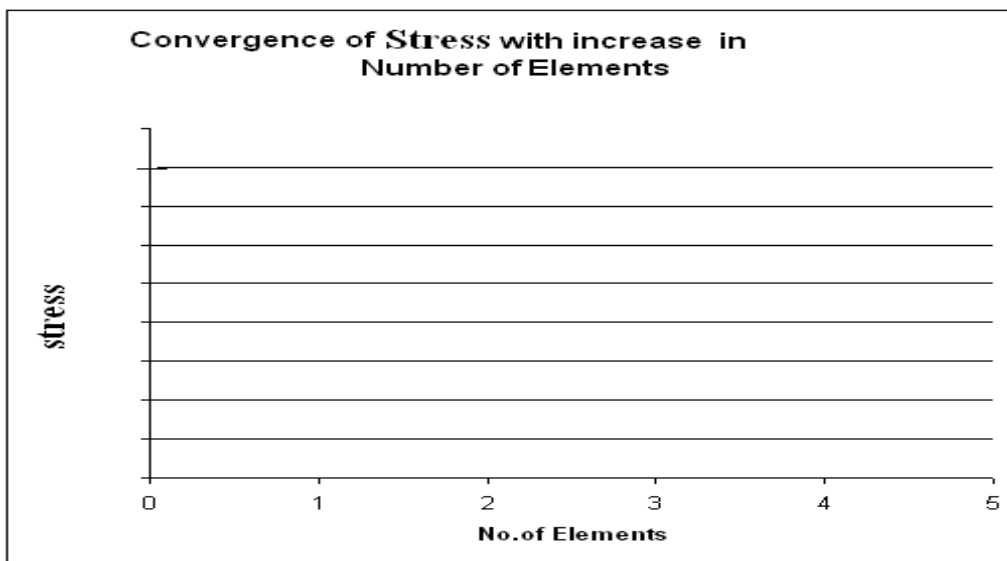

Graph of Convergence of tip stress with increase in number of elements

Problem 19: A copper bar of Length 160mm is placed on rigid support in vertical position. Clearance between the upper support and top surface of the member is 0.1mm as shown. Determine Stress and reactions for 1) when the temperature is raised by 34.7°C. 2) when the temperature is raised by 81°C. 3) when the temperature is raised by 90°C and upper support yields by 0.12mm and 4) when the temperature is raised by 30°C and there is no clearance between upper support and top surface of the bar. $E_c=120$ GPa and $\alpha = 18 \times 10^{-6}$ per °C. $A=10\text{mm}^2$

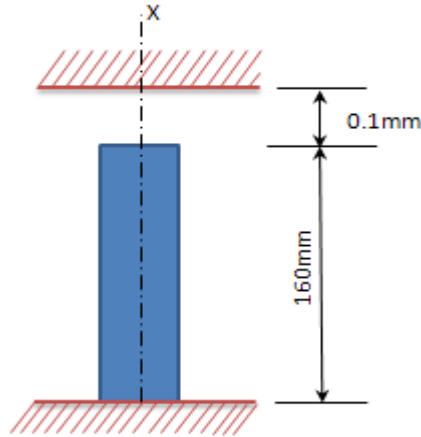

Note:

- Ansys Main Menu > Preprocessor > Material Properties > Material Models > Structural > Linear > Elastic > Isotropic > Specify Material No:= 1 > OK > Thermal expansion > secant coefficient > Isotropic > ALPX= 18 e-6
(and reference temperature if given) > ok
- Ansys Main Menu > Solver > loads Define Loads > apply > Structural > temp > uniform temp=(rise in temp+ reference temperature if given) > ok

Case	Description	Force-N	Stress in MPa -Ansys	Stress in MPa SOM
1.				
2.				
3.				
4.				

Problem 20: Find Nodal Displacements Stresses and reaction forces for the following problem using Link1 Element. Given data: $A1 = 40\text{mm}^2$, $A2 = 20\text{mm}^2$, Young's modulus $= 2 \times 10^5 \text{ N/mm}^2$

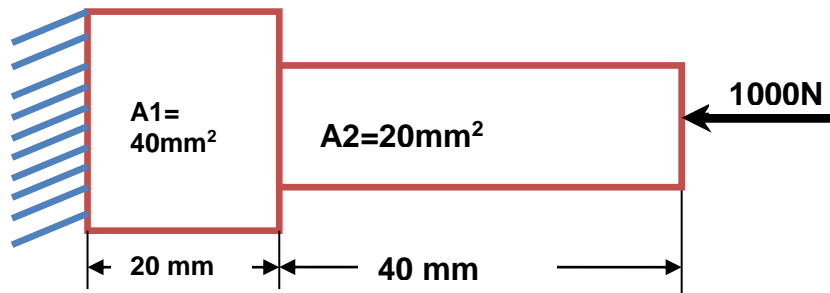

Results: NODAL SOLUTION- DISPLACEMENTS:

Node No.	Ux (mm)	Uy (mm)
1		
2		
3		

Results: ELEMENTAL SOLUTION- STRESSES:

Element No.	Stress(MPa)	Force (N)
1		
2		

Results: REACTION SOLUTION:

Node No.	Fx	Fy
1		
2		

Check $\sum F_x =$

$\sum F_y =$

Note: Compare Solutions with SOM

Problem21: Consider the bar shown in figure. An axial load $p=200 \times 10^3 \text{ N}$ is applied as shown. Determine 1) the nodal displacements and the reaction forces & 2) Element stresses.

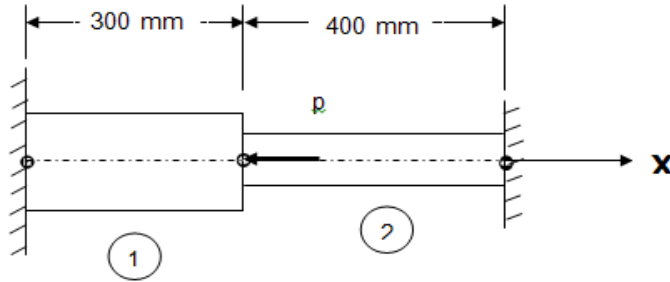

Area1 = 2400 mm^2

Young's modulus = $70 \times 10^9 \text{ N/m}^2$

Area 2= 600 mm^2

Young's modulus = $200 \times 10^9 \text{ N/m}^2$

Discretization (connectivity) and material properties

Sl. No.	Element No.	Node Nos.	Length	C/S	E (Gpa)
1					
2					

Answer

Sl. No.	Node No.	Deflection. mm	Load / Reaction N	Element No	Stress MPa	Force (N)
1				➤		
2				➤		
3						

Check $R1+R3+P = 0$

Problem 22: Determine the displacement field, support reactions & stress in the body shown as loaded. Use 1D bar elements.

Young's modulus = 20 Gpa

$A = 250 \text{ mm}^2$

$P = 60 \text{ kN}$

Case A

Case B & C

Also what will be these values for case B and Case C

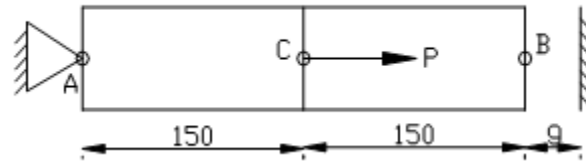
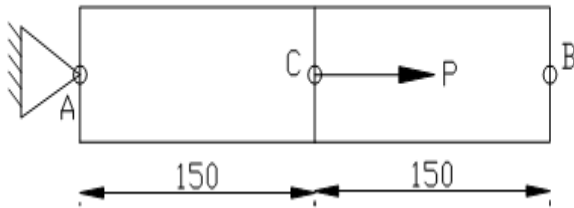

Case B : $g = 1.2 \text{ mm}$

Case C : $g = 2 \text{ mm}$

Answer

Sl. No	Node No.	CASE A		CASE B		CASE C	
		Displacement mm	Reaction N	Displacement mm	Reaction N	Displacement mm	Reaction N
1							
2							
3							
Stresses in element MPa	1						
	2						

Problem 23: (a) An axial load $P=300 \times 10^3$ N is applied at 20°C to the rod as shown in figure. Determine the nodal displacements, reactions and stresses.

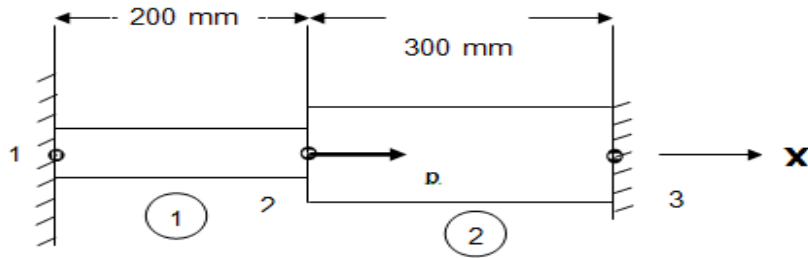

Aluminium

Area = 900 mm^2

Young's modulus = $70 \times 10^9 \text{ N/m}^2$

$\alpha = 23 \times 10^{-6} \text{ per}^\circ\text{C}$

Steel

Area = 1200 mm^2

Young's modulus = $200 \times 10^9 \text{ N/m}^2$

$\alpha = 11.7 \times 10^{-6} \text{ per}^\circ\text{C}$

Discretization (connectivity) and material properties

Sl. No.	Element No.	Node No.	Length	C/S	Material properties		
					E (Gpa)	α	
1	1	1-2					
2	2	2-3					

Answer

Sl. No.	Node No.	Deflection. mm	Load / Reaction N	Element No	Stress MPa	Force-N
1				1		
2				2		
3						

b) If the temperature is raised to 60°C . Determine displacement, reaction and stresses.

Answer

Sl. No.	Node No.	Deflection. mm	Load / Reaction N	Element No	Stress MPa	Force N
1				1		
2				2		
3						

Theory Do you know element load vector due to temperature change.

Problem 24: An axial load $P=300 \times 10^3$ N is applied at 20°C to the rod as shown in figure. Determine the nodal displacements, reaction and element stresses.

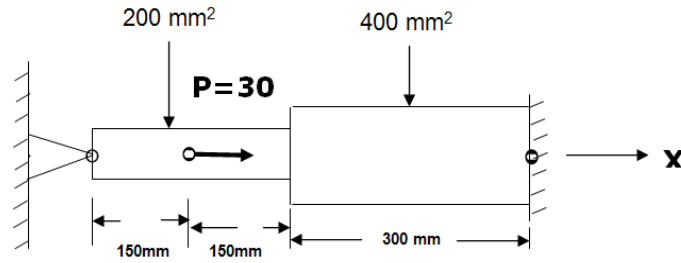

$E = 200 \times 10^9 \text{ N/m}^2$ (1 kN = 1000 N), $\alpha = 11.7 \times 10^{-6} \text{ per}^\circ\text{C}$

Discretization (connectivity) and material properties

Sl. No.	Element No.	Node no.	Length	C/S	Material properties		
					E (Gpa)	α	
1	1						
2	2						
3	3						

Answer

Sl. No.	Node No.	Deflection.	Load / Reaction	Element No	Stress
1					
2					
3					
4					

a) Solve the same if the temperature is raised to 60°C .

Answer

Sl. No.	Node No.	Deflection. mm	Load / Reaction N	Element No	Stress MPa
1					
2					
3					
4					

Problem 25: Consider the bar in figure. Determine the nodal displacements, element stresses and support reactions. a) At room temperature b) The temperature is then raised to 60°C

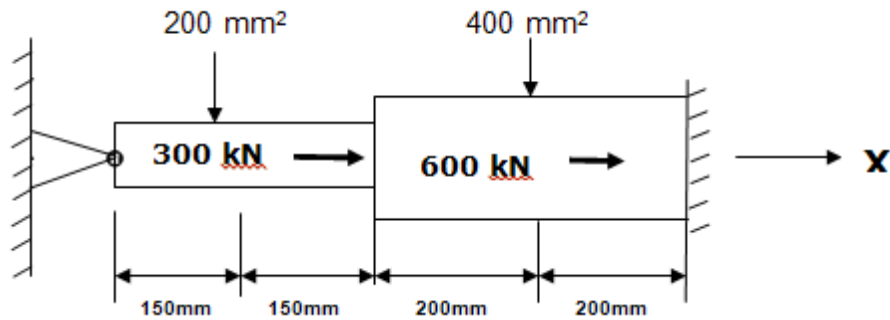

$\alpha = 11.7 \times 10^{-6}$ per°C Young's modulus = 200×10^9 N/m² ,

Discretization (connectivity) and material properties

Sl. No.	Element No.	No. of nodes	Length	C/S	Material properties		
					E (Gpa)	α	
1							
2							
3							
4							

Answer: Part A

Sl. No.	Node No.	Deflection. mm	Load / Reaction N	Element No	Stress MPa
1					
2					
3					
4					
5					

Answer:Part B

Sl. No.	Node No.	Deflection. mm	Load / Reaction N	Element No	Stress MPa
1					
2					
3					
4					
5					

Problem 26: For the structure shown

Case a-without temperature rise , Case b-with temperature rise of 80°C

- 1) Specify the type of element to be used.
- 2) Create finite element model showing element numbers & node numbers.
- 3) Specify the displacement and force boundary conditions
- 4) Obtain nodal reactions.
- 5) Displacement of various nodes. Identify maximum displacement with location
- 6) Stresses and force along each element.

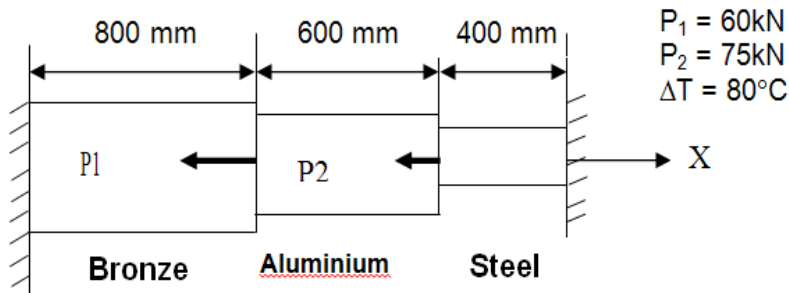

Bronze	Aluminium	Steel
A = 2400 mm ²	A = 1200 mm ²	A = 600 mm ²
E = 83 GPa	E = 70 GPa	E = 200 GPa
$\alpha = 18.9 \times 10^{-6}$ per°C	$\alpha = 23 \times 10^{-6}$ per°C	$\alpha = 11.7 \times 10^{-6}$ per°C

STEP1 NODE NUMBERING AND COORDINATES

NODE	X	Y
1	0.0000	0.0000
2	800.00	0.0000
3	1400.0	0.0000
4	1800.0	0.0000

STEP2 LIST ALL SELECTED ELEMENTS.

ELEM	NODES	Real Constant	AREA (mm ²)	MAT ID	E-MPa	α /°C
1	1,2	1	2400.00	1	83e3	18.9e-6
2	2,3	2	1200.00	2	70e3	23e-6
3	3,4	3	600.000	3	200e3	11.7e-6

STEP3 CURRENTLY SELECTED DOF SET= UX UY

NODE	LABEL	REAL
1	UX	0.00000000
1	UY	0.00000000
4	UX	0.00000000
4	UY	0.00000000

STEP 4 LIST NODAL FORCES FOR SELECTED NODES in Newton

NODE	LABEL	REAL
2	FX	-60000.0000
3	FX	-75000.0000

RESULTS

PARTICULAR	CASE A WITHOUT TEMPERATURE	CASE B WITH TEMPERATURE RISE of 80 deg.C																														
Displacements In mm	<table> <thead> <tr> <th>NODE</th> <th>UX</th> <th>USUM</th> </tr> </thead> <tbody> <tr> <td>1</td> <td>0.0000</td> <td>0.0000</td> </tr> <tr> <td>2</td> <td>-0.24347</td> <td>0.24347</td> </tr> <tr> <td>3</td> <td>-0.24792</td> <td>0.24792</td> </tr> <tr> <td>4</td> <td>0.0000</td> <td>0.0000</td> </tr> </tbody> </table> <p>MAXIMUM ABSOLUTE VALUES NODE 2 VALUE -0.24792</p>	NODE	UX	USUM	1	0.0000	0.0000	2	-0.24347	0.24347	3	-0.24792	0.24792	4	0.0000	0.0000	<table> <thead> <tr> <th>NODE</th> <th>UX</th> <th>USUM</th> </tr> </thead> <tbody> <tr> <td>1</td> <td>0.0000</td> <td>0.0000</td> </tr> <tr> <td>2</td> <td>0.22124</td> <td>0.22124</td> </tr> <tr> <td>3</td> <td>-0.40603E-02</td> <td>0.40603E-02</td> </tr> <tr> <td>4</td> <td>0.0000</td> <td>0.0000</td> </tr> </tbody> </table> <p>MAXIMUM ABSOLUTE VALUES NODE 2 VALUE 0.22124</p>	NODE	UX	USUM	1	0.0000	0.0000	2	0.22124	0.22124	3	-0.40603E-02	0.40603E-02	4	0.0000	0.0000
NODE	UX	USUM																														
1	0.0000	0.0000																														
2	-0.24347	0.24347																														
3	-0.24792	0.24792																														
4	0.0000	0.0000																														
NODE	UX	USUM																														
1	0.0000	0.0000																														
2	0.22124	0.22124																														
3	-0.40603E-02	0.40603E-02																														
4	0.0000	0.0000																														
REACTION IN NEWTON	<table> <thead> <tr> <th>NODE</th> <th>FX</th> <th>FY</th> </tr> </thead> <tbody> <tr> <td>1</td> <td>60624.</td> <td>0.0000</td> </tr> <tr> <td>4</td> <td>74376.</td> <td>0.0000</td> </tr> </tbody> </table> <p>TOTAL VALUES VALUE 0.13500E+06 0.0000</p>	NODE	FX	FY	1	60624.	0.0000	4	74376.	0.0000	<table> <thead> <tr> <th>NODE</th> <th>FX</th> <th>FY</th> </tr> </thead> <tbody> <tr> <td>1</td> <td>0.24610E+06</td> <td>0.0000</td> </tr> <tr> <td>4</td> <td>-0.11110E+06</td> <td>0.0000</td> </tr> </tbody> </table> <p>TOTAL VALUES VALUE 0.13500E+06 0.0000</p>	NODE	FX	FY	1	0.24610E+06	0.0000	4	-0.11110E+06	0.0000												
NODE	FX	FY																														
1	60624.	0.0000																														
4	74376.	0.0000																														
NODE	FX	FY																														
1	0.24610E+06	0.0000																														
4	-0.11110E+06	0.0000																														
ELEMENT STRESSES (LS,1) & MEMBER FORCE (SMISC,1) FROM ETABLE	<table> <thead> <tr> <th>ELEM</th> <th>STRESS (MPA)</th> <th>FORCE (NEWTON)</th> </tr> </thead> <tbody> <tr> <td>1</td> <td>-25.260</td> <td>-60624.</td> </tr> <tr> <td>2</td> <td>-0.51960</td> <td>-623.52</td> </tr> <tr> <td>3</td> <td>123.96</td> <td>74376.</td> </tr> </tbody> </table> <p>MINIMUM VALUES ELEM 1 VALUE -25.260 -60624.</p> <p>MAXIMUM VALUES ELEM 3 VALUE 123.96 74376.</p>	ELEM	STRESS (MPA)	FORCE (NEWTON)	1	-25.260	-60624.	2	-0.51960	-623.52	3	123.96	74376.	<table> <thead> <tr> <th>ELEM</th> <th>STRESS (MPA)</th> <th>FORCE (NEWTON)</th> </tr> </thead> <tbody> <tr> <td>1</td> <td>-102.54</td> <td>-0.24610E+06</td> </tr> <tr> <td>2</td> <td>-155.08</td> <td>-0.18610E+06</td> </tr> <tr> <td>3</td> <td>-185.17</td> <td>-0.11110E+06</td> </tr> </tbody> </table> <p>MINIMUM VALUES ELEM 3 VALUE -185.17 -0.24610E+06</p> <p>MAXIMUM VALUES ELEM 1 VALUE -102.54 -0.11110E+06</p>	ELEM	STRESS (MPA)	FORCE (NEWTON)	1	-102.54	-0.24610E+06	2	-155.08	-0.18610E+06	3	-185.17	-0.11110E+06						
ELEM	STRESS (MPA)	FORCE (NEWTON)																														
1	-25.260	-60624.																														
2	-0.51960	-623.52																														
3	123.96	74376.																														
ELEM	STRESS (MPA)	FORCE (NEWTON)																														
1	-102.54	-0.24610E+06																														
2	-155.08	-0.18610E+06																														
3	-185.17	-0.11110E+06																														

Problem 27: Three equidistant vertical rods, each of 20mm dia, support a load as shown taking $E_s=205\text{GPa}$ and $E_c=100\text{GPa}$ determine the final stresses

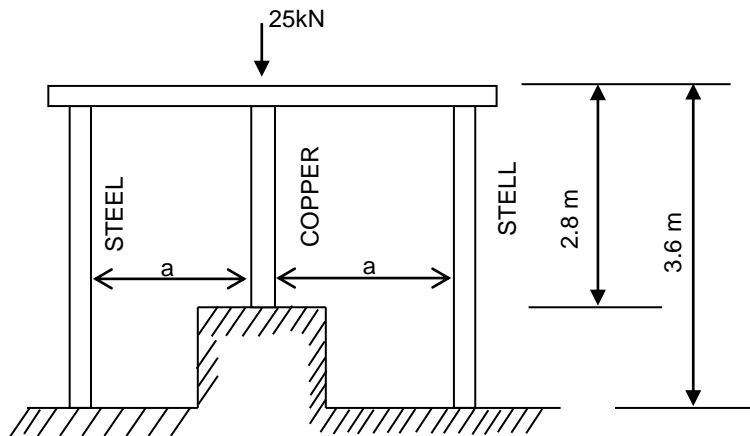

Given Data:

$L_s=3.6\text{m}$,
 $L_c=2.8\text{m}$,
 $d=20\text{mm}$

Hint : Horizontal bar remains horizontal. Hence the upper ends of all the vertical bars move together vertically. So we need to couple them in U_y . Assume $a=1000\text{mm}$.

Procedure

- Ansysis Main Menu > Preferences > Structural > Ok
- Ansysis Main Menu > Preprocessor > Element type > Add/edit/delete > add >LINK > 3D Finite Stn> OK > close
- Ansysis Main Menu > Preprocessor > Sections > Link > Add > Add Link section with ID=1, Section Name= 'area1', Area= $3.142 \cdot 20^2 / 4$ > ok
- Ansysis Main Menu > Preprocessor > Material Properties > Material Models > Structural > Linear > Elastic >Isotropic> EX= 205E3, PRXY= 0.3, OK> Material>New Model> Specify Material No: = 2> OK> EX= 100E3, PRXY= 0.3, OK
- Ansysis Main Menu > Preprocessor >Modeling> Create > Nodes > in active CS > Set Node No: = 1, X=0, Y=0, Z=0 > Apply > Set Node No: =2, X= 0, Y=3600, Z=0 > Apply > Set Node No: =3, X= 1000, Y=800, Z=0 > Apply > Set Node No: =4, X= 1000, Y=3600, Z=0 > Apply >Set Node No: =5, X= 2000, Y=0, Z=0 >Apply > set Node No:=6, X= 2000, Y = 3600, Z=0 >OK
- Ansysis Main Menu > Preprocessor > Modeling > Create > elements > Element Attributes > Material no. = 1, Real constant set no. = 1 > ok
- Ansysis Main Menu > Preprocessor > Modeling > Create > elements > Auto numbered > Thru Nodes > Pick nodes 1 and 2 > Apply > pick nodes 5 and 6 > ok
- Ansysis Main Menu > Preprocessor > Modeling > Create > elements > Element Attributes > Material no. = 2, Real constant set no. = 1 > ok
- Ansysis Main Menu > Preprocessor > Modeling > Create > elements > Auto numbered > Thru Nodes > Pick nodes 3 and 4 > ok
- Ansysis Main Menu > Preprocessor > Coupling/Ceqn > Couple DOFs > pick nodes 2, 4 and 6, ok > set reference no. = 1, Degree of freedom label = U_y > ok
- Ansysis Main Menu > Preprocessor > Loads > Define Loads > Apply > Structural > Displacement > On Nodes > Pick nodes 1, 3 and 5, Ok> DOFs to be constrained= All DOF, ok.

Ansys Main Menu > Preprocessor > loads > Define Loads > apply > Structural > Force/Moment > On Nodes > Pick node 4 > Ok > Select **Fy= -25e3, ok**

Ansys Main Menu > solution > Solve Current LS > OK

Ansys main menu > general post processor > Element table > Define table > Add > set user label for item = **STRESS**, select item, comp, results data item = by sequence number- select **LS, 1** (Type 1 after selecting LS) > OK > set user label for item = **FORCE**, select item, comp, results data item = by sequence number- select **SMISC,1**>Close

Ansys Main Menu > General Post Processor > Element Table > List Element Table > Select STRESS & FORCE > OK > Note the stress & Force in elements

Ansys Main Menu > General Post Processor > List Results > Nodal Solution > Dof solution > x component of DOFs > Ok (Note the Nodal displacement results)

Ansys Main Menu > General Post Processor > List Results > Reaction Solutions > Select all items > OK > (Note the reaction solution)

RESULTS:

Results: NODAL SOLUTION- DISPLACEMENTS:

Node No.	Ux (mm)	Uy (mm)	Uz(mm)
1			
2			
3			

Results: ELEMENTAL SOLUTION- STRESSES:

Element No.	Stress(MPa)	Force (N)
1		
2		
3		

Results: REACTION SOLUTION:

Node No.	Fx	Fy	Fz
1			
2			
3			

Problem 28: Three equally spaced rods in the same vertical are Brasses, each 600mm long and of 25mm in dia, The central rod is of steel that is 800mm long and 30mm in dia, determine the forces in each rods due to an applied load of 120kN downwards through the midpoint of the bar, The bar remains horizontal after the application of load. Take $E_s=200\text{GPa}$ and $E_b=105\text{GPa}$.

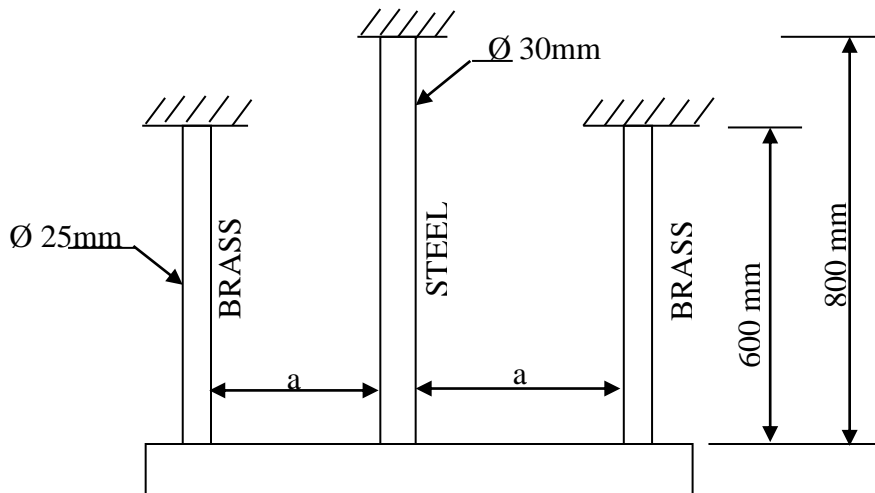

RESULTS :

Results: NODAL SOLUTION- DISPLACEMENTS:

Node No.	Ux (mm)	Uy (mm)	Uz(mm)
1			
2			
3			

Results: ELEMENTAL SOLUTION- STRESSES:

Element No.	Stress(MPa)	Force (N)
1		
2		
3		

Results: REACTION SOLUTION:

Node No.	Fx	Fy	Fz
1			
2			
3			

Problem 29: A rigid horizontal bar AB hinged at A is supported by a 1.2m long steel rod and a 2.4m long bronze rod, both rigidly fixed at the upper ends, A load of 48kN is applied at a point that is 3.2m from the hinge point A, the areas of cross-section of steel and bronze rods are 850mm² and 650mm² respectively. Find stress in each rod.

Given Data:

$$A_s=850\text{mm}^2 \quad A_b=650\text{mm}^2$$

$$E_s=205\text{GPa} \quad E_b=82\text{GPa}$$

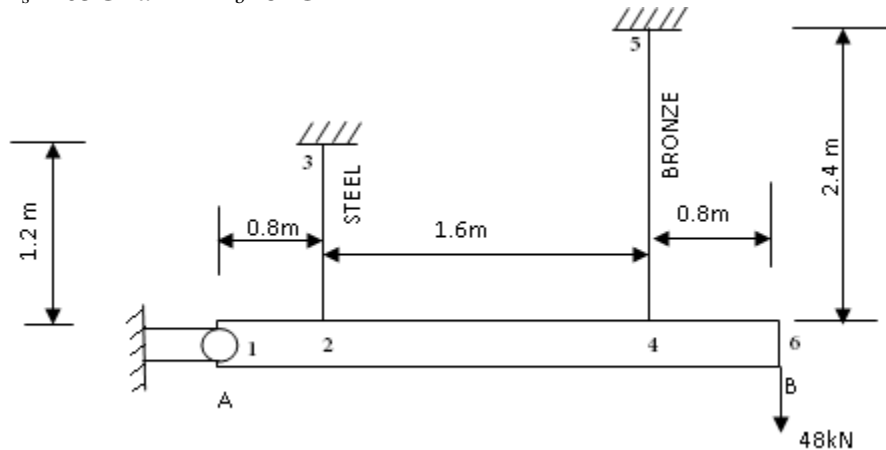

Hint : Model AB with three **MPC184** elements(constraint element) with '**Rigid beam**' element option. Allow **Rotz DOF** for node at A.

Procedure

Ansys Main Menu > Preferences > Structural > Ok

Ansys Main Menu > Preprocessor > ELEMENT type > Add/edit/delete > add > **LINK** > **3D Finite Stn** > OK

Ansys Main Menu > Preprocessor > ELEMENT type > Add/edit/delete > add > **Constraint** > **Non linear MPC184** > OK > **Options** > **K1 Rigid Beam** > **K2 Lagrange Multiplier** > OK

Ansys Main Menu > Preprocessor > Sections > Link > Add > Add Link section with ID=1, Section Name= 'area1', Area=850 > Apply > Add Link section with ID= 2, Section Name= 'area2', Area=650 > ok.

Ansys Main Menu > Preprocessor > Material Properties > Material Models > Structural > Linear > Elastic > Isotropic > EXX= 205E3, PRXY= 0.3, OK > Material > New Model > Specify Material No: = 2 > OK > EXX= 82E3, PRXY= 0.3, OK

Ansys Main Menu > Preprocessor > Modeling > Create > Nodes > in active CS >

Set Node No: = 1, X=0, Y=0, Z=0 > Apply > Set Node No: =2, X= 800, Y=0, Z=0 > Apply >

Set Node No: =3, X= 800, Y=1200, Z=0 > Apply > Set Node No: =4, X= 2400, Y=0, Z=0 > Apply > Set Node No: =5, X= 2400, Y=2400, Z=0 > Apply > set Node No: =6, X= 3200, Y = 0, Z=0 > OK

Ansys Main Menu > Preprocessor > Modeling > Create (Check Element attributes) > elements > Auto numbered > Thru Nodes > Pick 2&3 nodes > OK

Ansys Main Menu > Preprocessor > Modeling > Create > elements > Elements Attributes > Set Element Type No 1 **LINK1**, Set Material No. 2, Set real constant set No: = 2 > OK

Ansys Main Menu > Preprocessor > Modeling > Create > elements > Thru Nodes > Pick nodes 4&5 node > OK

Ansys Main Menu > Preprocessor > Modeling > Create > elements > Elements Attributes > Set Element Type No **1MPC184**, > OK

Ansys Main Menu > Preprocessor > Modeling> Create> elements> Thru Nodes> Pick nodes 1&2,2&4, and 4&6> OK

Ansys Main Menu > Preprocessor > Loads > Define Loads > apply > Structural Displacement > On Nodes > Pick 1 Ok > Select **UX,UY,UZ,ROTX,ROTY**> Ok

Ansys Main Menu > Preprocessor > Loads > Define Loads > apply > Structural Displacement > On Nodes > Pick 3 &5 Ok>Select **All Dof**> Ok

Ansys Main Menu > Preprocessor > loads > Define Loads > apply > Structural >Force/Moment > On Nodes > Pick 6th Node > Ok > Select **Fy= -48000**

Ansys Main Menu > solution >Solve Current LS >OK Soln Done > Close

Ansys main menu > general post processor > Element table > Define table > Add > set user label for item = **STRESS**, select item, comp, results data item = by sequence number- select **LS, 1** (Type 1 after selecting LS) > OK > set user label for item = **FORCE**, select item, comp, results data item = by sequence number- select **SMISC,1**>Close

Ansys Main Menu > General Post Processor > Element Table > List Element Table > Select STRESS & FORCE > OK > Note the stress & Force in elements

Ansys Main Menu > General Post Processor > List Results > Nodal Solution >Dof solution > x component of DOFs > Ok (Note the Nodal displacement results)

Ansys Main Menu > General Post Processor > List Results > Reaction Solutions > Select all items > OK > (Note the reaction solution)

RESULTS:

Results: NODAL SOLUTION- DISPLACEMENTS:

Node No.	Ux (mm)	Uy (mm)	Uz (mm)
1			
2			
3			
4			
5			
6			

Results: ELEMENTAL SOLUTION- STRESSES:

Element No.	Stress(MPa)	Force (N)
__ (Steel)		
__ (Bronze)		

Results: REACTION SOLUTION:

Node No.	Fx	Fy	Fz
1			
3			
5			

Chapter7: Problems on Beams

3-D 2-Node Beam (**beam188, beam189**) geometry

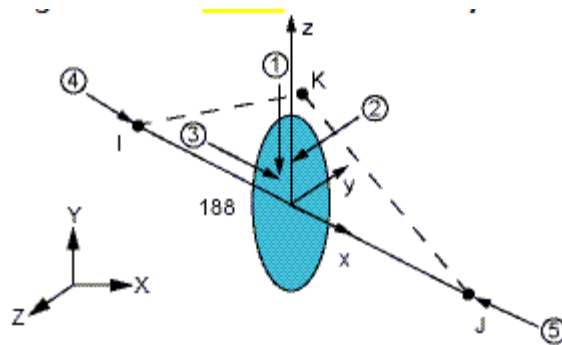

Fig.7.1

Element Description:

BEAM188 is suitable for analyzing slender to moderately stubby/thick beam structures. The element is based on Timoshenko beam theory which includes shear-deformation effects. The element provides options for unrestrained warping and restrained warping of cross-sections.

The element is a linear, quadratic, or cubic two-node beam element in 3-D. BEAM188 has six or seven degrees of freedom at each node. These include translations in the x, y, and z directions and rotations about the x, y, and z directions. A seventh degree of freedom (warping magnitude) is optional. This element is well-suited for linear, large rotation, and/or large strain nonlinear applications.

The element includes stress stiffness terms, by default, in any analysis with large deflection. The provided stress-stiffness terms enable the elements to analyze flexural, lateral, and torsional stability problems (using eigenvalue buckling, or collapse studies with arc length methods or nonlinear stabilization).

Elasticity, plasticity, creep and other nonlinear material models are supported. A cross-section associated with this element type can be a built-up section referencing more than one material.

Assumptions and Restrictions:

- The beam must not have zero length.
- By default (KEYOPT(1) = 0), the effect of warping restraint is assumed to be negligible.
- Cross-section failure or folding is not accounted for.
- Rotational degrees of freedom are not included in the lumped mass matrix if offsets are present.
- The element works best with the full Newton-Raphson solution scheme (that is, the default choice in solution control).

- Only moderately "thick" beams can be analyzed. See "BEAM188 Element Technology and Usage Recommendations" for more information.
- Stress stiffening is always included in geometrically nonlinear analyses (NLGEOM,ON). Prestress effects can be activated by the PSTRES command.
- When the element is associated with nonlinear general beam sections (SECTYPE,,GENB), additional restrictions apply. For more information, see Considerations for Using Nonlinear General Beam Sections.
- The element coordinate system (/PSYMB,ESYS) is not relevant.
- For a random vibration (PSD) analysis, equivalent stress is not calculated.

BEAM188 Input Data:

The geometry, node locations, coordinate system, and pressure directions for this element are shown in Figure 7.1. BEAM188 is defined by nodes I and J in the global coordinate system.

Node K is a preferred way to define the orientation of the element. For information about orientation nodes and beam meshing, see *Generating a Beam Mesh With Orientation Nodes in the Modeling and Meshing Guide*. See the LMESH and LATT command descriptions for details on generating the K node automatically.

BEAM188 can also be defined without the orientation node K. In this case, the element x-axis is oriented from node I (end 1) toward node J (end 2). If no orientation node is used, the default orientation of the element y-axis is automatically calculated to be parallel to the global X-Y plane. For the case where the element is parallel to the global Z-axis (or within a 0.01 percent slope of it), the element y-axis is oriented parallel to the global Y-axis (as shown). To control the element orientation about the element x-axis, use the orientation-node option. If both are defined, the orientation-node option takes precedence. The orientation node K, if used, defines a plane (with I and J) containing the element x and z-axes (as shown). If using this element in a large-deflection analysis, be aware that the location of the orientation node K is used only to initially orient the element.

The number of degrees of freedom depends on the value of KEYOPT(1). When KEYOPT(1) = 0 (the default), six degrees of freedom occur at each node. These include translations in the x, y, and z directions and rotations about the x, y, and z directions. When KEYOPT(1) = 1, a seventh degree of freedom (warping magnitude) is also considered.

The beam element is a one-dimensional line element in space. The cross-section details are provided separately via the SECTYPE and SECDATA commands. (See *Beam Analysis and cross-sections in the Structural Analysis Guide* for details). A section is associated with the beam elements by specifying the section ID number (SECNUM). A section number is an independent element attribute. In addition to a constant cross-section, you can also define a tapered cross-section by using the TAPER option on the SECTYPE command (see *Defining a Tapered Beam*).

BEAM188 Input Summary

Nodes

I, J, K (K, the orientation node, is optional but recommended)

Degrees of Freedom

UX, UY, UZ, ROTX, ROTY, ROTZ if KEYOPT(1) = 0

UX, UY, UZ, ROTX, ROTY, ROTZ, WARP if KEYOPT(1) = 1

Section Controls

TXZ, TXY, ADDMAS (See **SECCONTROLS**)

(TXZ and TXY default to $A*GXZ$ and $A*GXY$, respectively, where A = cross-sectional area)

Material Properties

EX, (PRXY, or NUXY), GXY, GXZ ALPX, (or CTEX, or THSX) DENS, ALPD, BETD

Surface Loads

Pressure --

face 1 (I-J) (-z normal direction)

face 2 (I-J) (-y normal direction)

face 3 (I-J) (+x tangential direction)

face 4 (I) (+x axial direction)

face 5 (J) (-x axial direction)

I and J denote the end nodes.

Use a negative value for loading in the opposite direction.

Issue the **SFBEAM** command to specify surface loads.

For faces 1, 2, and 3, offsets apply only if you are using the cubic option (KEYOPT(3) = 3).

Body Loads

Temperatures -- T(0,0), T(1,0), T(0,1) at each end node

KEYOPT(1)

Warping degree of freedom:

0 -- Six degrees of freedom per node, unrestrained warping (default)

1 -- Seven degrees of freedom per node (including warping). Bimoment and bicurvature are output.

KEYOPT(2)

Cross-section scaling, applies only if NLGEOM,ON has been invoked:

0 -- Cross-section is scaled as a function of axial stretch (default)

1 -- Section is assumed to be rigid (classical beam theory)

KEYOPT(3)

Shape functions along the length:

0 -- Linear (default)

2 -- Quadratic

3 -- Cubic

KEYOPT(4)

Shear stress output:

- 0 -- Output only torsion-related shear stresses (default)
- 1 -- Output only flexure-related transverse-shear stresses
- 2 -- Output a combined state of the previous two types

KEYOPT(6), KEYOPT(7), and KEYOPT(9)

active only when OUTPR,ESOL is active:

KEYOPT(6)

Output control for section forces/moments and strains/curvatures:

- 0 -- Output section forces/moments and strains/curvatures at integration points along the length (default)
- 1 -- Same as KEYOPT(6) = 0 plus current section area
- 2 -- Same as KEYOPT(6) = 1 plus element basis directions (X,Y,Z)
- 3 -- Output section forces/moments and strains/curvatures extrapolated to the element nodes

KEYOPT(7)

Output control at integration points (not available when section subtype = ASEC):

- 0 -- None (default)
- 1 -- Maximum and minimum stresses/strains
- 2 -- Same as KEYOPT(7) = 1 plus stresses and strains at each section point

KEYOPT(9)

Output control for values extrapolated to the element and section nodes (not available when section subtype = ASEC):

- 0 -- None (default)
- 1 -- Maximum and minimum stresses/strains
- 2 -- Same as KEYOPT(9) = 1 plus stresses and strains along the exterior boundary of the cross-section
- 3 -- Same as KEYOPT(9) = 1 plus stresses and strains at all section nodes

KEYOPT(11)

Set section properties:

- 0 -- Automatically determine if preintegrated section properties can be used (default)
- 1 -- Use numerical integration of section

KEYOPT(12)

Tapered section treatment:

- 0 -- Linear tapered section analysis; cross-section properties are evaluated at each Gauss point (default). This is more accurate, but computationally intensive.
- 1 -- Average cross-section analysis; for elements with tapered sections, cross-section properties are evaluated at the centroid only. This is an approximation of the order of the mesh size; however, it is faster.

KEYOPT(15)

Results file format:

- 0 -- Store averaged results at each section corner node (default).
- 1 -- Store non-averaged results at each section integration point. (The volume of data may be excessive. This option is typically useful for built-up sections with multiple materials only.)

BEAM188 Output Data

The solution output associated with these elements is in two forms:

Nodal displacements and reactions included in the overall nodal solution

Additional element output as described in Table 7.1: BEAM188 Element Output Definitions

To view 3-D deformed shapes for BEAM188, issue an OUTRES,MISC or OUTRES,ALL command for static or transient analyses. To view 3-D mode shapes for a modal or eigenvalue buckling analysis, you must expand the modes with element results calculation active (via the MXPAND command's Elcalc = YES option).

Linearized Stress

It is customary in beam design to employ components of axial stress that contribute to axial loads and bending in each direction separately; therefore, BEAM188 provides a linearized stress output as part of its SMISC output record, as indicated in the following definitions:

SDIR is the stress component due to axial load.

$SDIR = F_x/A$, where F_x is the axial load (SMISC quantities 1 and 14) and A is the area of the cross-section.

SByT and SByB are bending-stress components.

$$SByT = -M_z * y_{max} / I_{zz}$$

$$SByB = -M_z * y_{min} / I_{zz}$$

$$SBzT = M_z * z_{max} / I_{yy}$$

$$SBzB = M_z * z_{min} / I_{yy}$$

where M_y , M_z are bending moments in the beam coordinate system (SMISC quantities 2,15,3,16), as shown in Figure 7.1. Coordinates y_{max} , y_{min} , z_{max} , and z_{min} are the maximum and minimum y , z coordinates in the cross-section measured from the centroid. Values I_{yy} and I_{zz} are moments of inertia of the cross-section. Except for the ASEC type of beam cross-section, the program uses the maximum and minimum cross-section dimensions. For the ASEC type of cross-section, the maximum and minimum in each of y and z direction is assumed to be +0.5 to -0.5, respectively.

Corresponding definitions for the component strains are:

$$EPELDIR = E_x$$

$$EPELByT = -K_z * y_{max}$$

$$EPELByB = -K_z * y_{min}$$

$$EPELBzT = Kz * zmax$$

$$EPELBzB = Kz * zmin$$

where E_x , K_y , and K_z are generalized strains and curvatures (SMISC quantities 7,8,9, 20,21 and 22).

The reported stresses are strictly valid only for elastic behavior of members. BEAM188 always employs combined stresses in order to support nonlinear material behavior. When the elements are associated with nonlinear materials, the component stresses can at best be regarded as linearized approximations and should be interpreted with caution.

When using KEYOPT(7) with the cubic option (KEYOPT(3) = 3), the integration point at the middle of the element is reported last in the integration-point printout.

The Element Output Definitions table uses the following notation:

A colon (:) in the Name column indicates that the item can be accessed by the Component Name method (ETABLE, ESOL). The O column indicates the availability of the items in the file Jobname.OUT. The R column indicates the availability of the items in the results file.

In either the O or R columns, “Y” indicates that the item is always available, a number refers to a table footnote that describes when the item is conditionally available, and “-” indicates that the item is not available.

Table 7.1 BEAM188 Element Output Definitions

Name	Definition	O	R
EL	Element number	Y	Y
NODES	Element connectivity	Y	Y
MAT	Material number	Y	Y
C.G.:X, Y, Z	Element center of gravity	Y	<u>1</u>
Area	Area of cross-section	<u>2</u>	Y
SF:y, z	Section shear forces	<u>2</u>	Y
SE:y, z	Section shear strains	<u>2</u>	Y
S:xx, xy, xz	Section point stresses	<u>3</u>	Y
TQ	Torsional moment	Y	Y
Fx	Axial force	Y	Y
My, Mz	Bending moments	Y	Y
SDIR	Axial direct stress	-	<u>2</u>
SByT	Bending stress on the element +Y side of the beam	-	Y
SByB	Bending stress on the element -Y side of the beam	-	Y
SBzT	Bending stress on the element +Z side of the beam	-	Y
SBzB	Bending stress on the element -Z side of the beam	-	Y

1. Available only at the centroid as a ***GET** item.
2. See KEYOPT(6) description.
3. See KEYOPT(7) and KEYOPT(9) descriptions.
4. See KEYOPT(1) description.
5. Available if the element has a nonlinear material.
6. Available only if **OUTRES,LOCI** command is used.
7. Available only if the UserMat subroutine and **TB,STATE** command are used.

More output is described via the **PRESOL** and ***GET,SECR** commands in POST1.

Table 7.2: BEAM188 Item and Sequence Numbers lists output available via **ETABLE** using the Sequence Number method. See Creating an Element Table in the *Basic Analysis Guide* and The Item and Sequence Number Table in this manual for more information. Table 7.2: BEAM188 Item and Sequence Numbers uses the following notation:

Name output quantity as defined in the Table 7.1: BEAM188 Element Output Definitions
Item predetermined Item label for **ETABLE**
I,J sequence number for data at nodes I and J

Table 7.2 BEAM188 Item and Sequence Numbers

Output Quantity Name	ETABLE and ESOL Command Input		
	Item	I	J
Fx	SMISC	1	14
My	SMISC	2	15
Mz	SMISC	3	16
TQ	SMISC	4	17
SFz	SMISC	5	18
SFy	SMISC	6	19
Ex	SMISC	7	20
Ky	SMISC	8	21
Kz	SMISC	9	22
TE	SMISC	10	23
SEz	SMISC	11	24
SEy	SMISC	12	25
SDIR	SMISC	31	36
SByT	SMISC	32	37
SByB	SMISC	33	38
SBzT	SMISC	34	39
SBzB	SMISC	35	40
S:xx, xy, xz	LS	CI[1], DI[2]	CJ[1], DJ[2]

Types of support conditions in 2D:

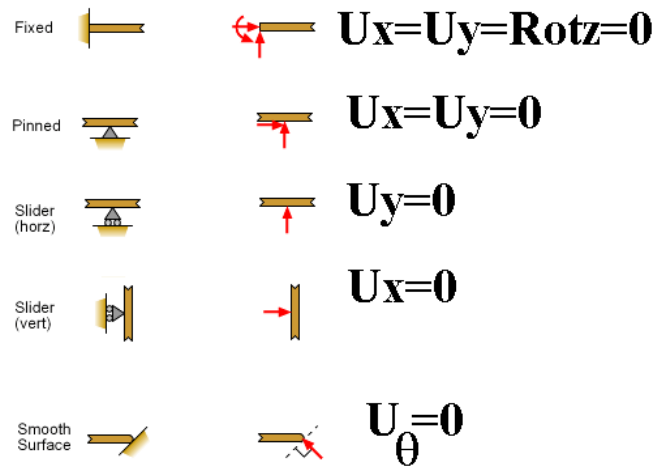

Problem 30: Effect of Self Weight on a Cantilever Beam. The beam is to be made of steel with a modulus of elasticity of 200 GPa. $L=1000\text{mm}$, $W=50\text{mm}$, $h=10\text{mm}$. Density = 7860 Kg/m^3

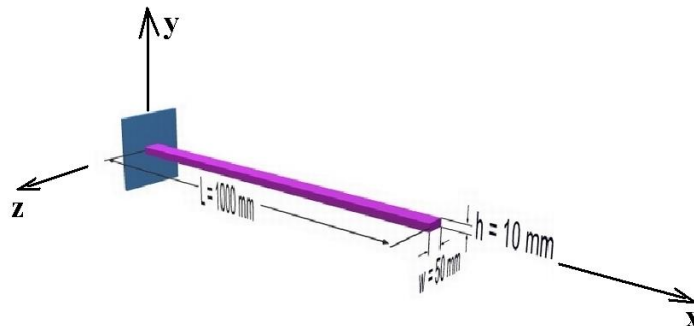

Preprocessing: Defining the Problem

1. Define the Type of Element: Preprocessor > Element Type > Add/Edit/Delete > Beam > 3D Finite Strain > Ok > Options > K3 > select Cubic Form > Ok
2. Define Element Material Properties: Preprocessor > Material Props > Material Models > Structural > Linear > Elastic > Isotropic > EX= 2E5, PRXY=0.3
3. Define Material Density: Preprocessor > Material Props > Material Models > Structural > Linear > Density > DENS=7.86e-6 > Ok
4. Define Cross sectional Area: Preprocessor > Sections > Beam > Common Sections, B=50, H=10 > Ok
5. Define Keypoints: Preprocessor > Modeling > Create > Key points > In ActiveCS
 $X=0, Y=0, Z=0$ > Apply >
 $X= 1000, Y=0, Z=0$ > Apply >
 $X=0, Y=500, Z=0$ > OK
 (Last KP is **ORIENTATION KEYPOINT** - for orienting the beam cross section)
 PlotCtrls > Numbering > Tick "ON" Keypoint Numbers > OK
6. Create Lines: Preprocessor > Modeling > Create > Lines > Lines > Straight line > pick KP's 1 and 2 to create the line.
7. Define the orientation of the beam cross section: Preprocessor > Meshing > Mesh Attributes > All lines > Tick 'YES' in Pick **Orientation Keypoint(s)** > Ok > Pick KP 3 (**Orientation Keypoint**) > OK

8. Define Mesh Size: Preprocessor > Meshing > Size Cntrls > ManualSize > Lines > All Lines

For this example we will use an SIZE element edge length=100mm.

9. Mesh the model: Preprocessor > Meshing > Mesh > Lines > click 'Pick All'

Solution Phase: Assigning Loads and Solving

1. Apply Constraints: Solution > Define Loads > Apply > Structural > Displacement > On Keypoints > pick keypoint 1 > ok > pick **All DOF** > ok
2. Define Gravity: It is necessary to define the direction and magnitude of gravity for this problem as we need to account self weight of the beam.
 - o Select Solution > Define Loads > Apply > Structural > Inertia > Gravity > Global. The following window will appear. Fill it in as shown to define an acceleration of 9.81 (m/s²) in the y direction.

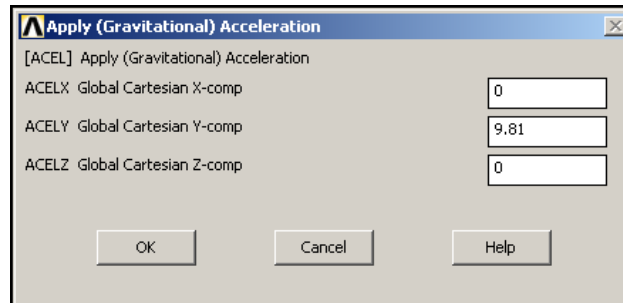

Note: Acceleration is defined in terms of meters (not 'mm' as used throughout the problem). This is because the units of acceleration and mass must be consistent to give the product of force units (Newtons in this case). Also note that **a positive acceleration in the y direction stimulates gravity in the negative y direction.**

There should now be a red arrow pointing in the positive y direction. This indicates that acceleration has been defined in the y direction.

The applied loads and constraints should now appear as shown in the figure below.



3. Solve the System
Solution > Solve > CurrentLS > SOLVE

Postprocessing: Viewing the Results

1. Hand Calculations

Perform SOM calculations to verify the solution found using ANSYS:

Show the deformation of the beam

General Postproc > Plot Results > Deformed Shape > Def + undefedge

(Blue line indicates deformed shape and white line indicates original shape)

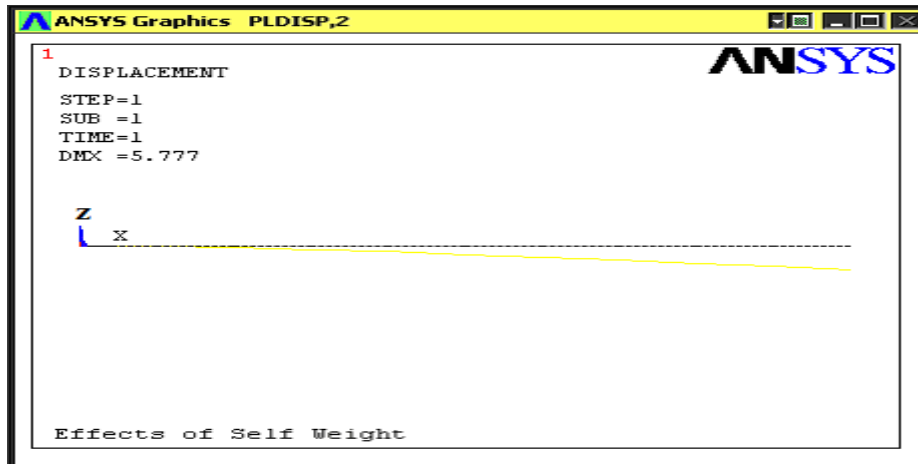

As observed in the upper left hand corner, the maximum displacement was found to be 5.777mm. This is in agreement with the theoretical value.

2. General Post Processor > List Results > Nodal Solutions> DOF Solution>Displacement vector sum>OK > You will get a list of deflection results
3. General Post Processor > List Results > Reaction Solutions> all items >OK > note down the values. Check for equilibrium
4. General Post Processor > List Results > Nodal Solutions> DOF Solution> Rotation vector sum > OK > You will get a list of slope results (in terms of radians)
5. Carry out animation also: Plot Ctrls > Animate > Deformed Shape > Def+undeformed > Ok

For BEAM188 element, use the following sequence numbers:

Entity	At the starting node(I) of the element	At the ending node(J) of the element
Shear force	SMISC,5	SMISC,18
Bending moment	SMISC,2	SMISC,15
Combined Max stress	SMISC,34	SMISC,39
Combined Min stress	SMISC,35	SMISC,40
Axial thrust	SMISC,1	SMISC,14
Axial direct stress	SMISC,31	SMISC,36

* You can also find these in the element description of BEAM188 in ANSYS help

6. General post processor > Element table > Define table > Add > set user label for item = **SFD5**, select item, comp, results data item = by sequence number- select **SMISC, 5** (Type 5 after selecting SMISC) > Apply > set user

label for item = **SFD18**, select item, comp, results data item = by sequence number- select **SMISC, 18** (Type 18 after selecting SMISC) > Apply > set user label for item = **BMD2**, select item, comp, results data item = by sequence number- select **SMISC,2** (Type 2 after selecting SMISC) > Apply > set user label for item = **BMD15**, select item, comp, results data item = by sequence number- select **SMISC, 15** (Type 15 after selecting SMISC) > Apply > OK > Close

7. General Post Processor > Element Table > List Element Table > Select **SFD5, SFD18, BMD2, BMD15** > OK > Tabulate the shear Force and Bending Moment values at each node.
(Similarly you can list the stresses also)
8. General Post Processor >Plot Results > contour plot > Line element res> Select **SFD5, SFD18**, > OK > Note down the SFD displayed.

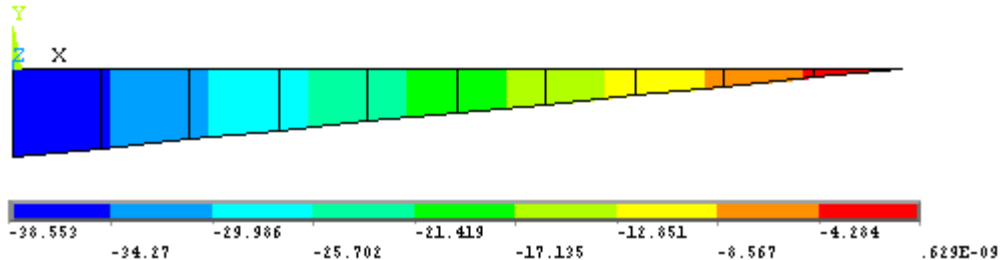

10. General Post Processor >Plot Results > contour plot > Line element res>Select **BMD2, BMD15**, > OK > Note down the BMD displayed.

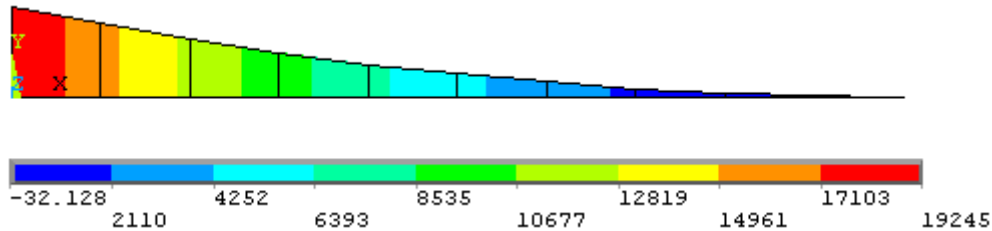

11. Plot Ctrl's > Style > Size & Shape > Display of element= ON > ok. This will show the beam with assigned element orientation and cross section.

BEAM- ANALYSIS REPORT

Step1: Name and sketch the element to be used showing its degree of freedom

Step2: Sketch of the given beam. Show the origin and XYZ axes.

Step3: List the co-ordinates of key point / nodes in a table (specify units)

Keypoint/ Node number	Coordinates		
	x	y	z
1			
2			
3 (orientation KP)			

Step4: Tabulate section parameters (based on Beam std. sections) and material properties

Sl No.	Element No.	Section parameters	Moment of inertia (ANSYS)	Material no. and value of E in MPa

Step 5: Sketch the FE model showing node numbers and element numbers

Step 6: List

a) Displacement boundary conditions to be incorporated						
Node No.	Ux	Uy	Uz	Rotx	Roty	Rotz

Translations are in mm and rotations are in radians

b) Force/Moment boundary conditions to be incorporated						
Node No.	Fx	Fy	Fz	Mx	My	Mz

Forces are in N and Moments are in N-mm

Solution:**Step7:** List Reaction solution

Node No.	Rx	Ry	Rz	RMx	RMy	RMz

Show them on the sketch and check for $\Sigma F_x = 0$, $\Sigma F_y = 0$, $\Sigma F_z = 0$, $\Sigma M_x = 0$, $\Sigma M_y = 0$, $\Sigma M_z = 0$,

Also calculate reactions from fundamentals and compare with the ANSYS values. Ensure that they are same, else doesn't proceed.

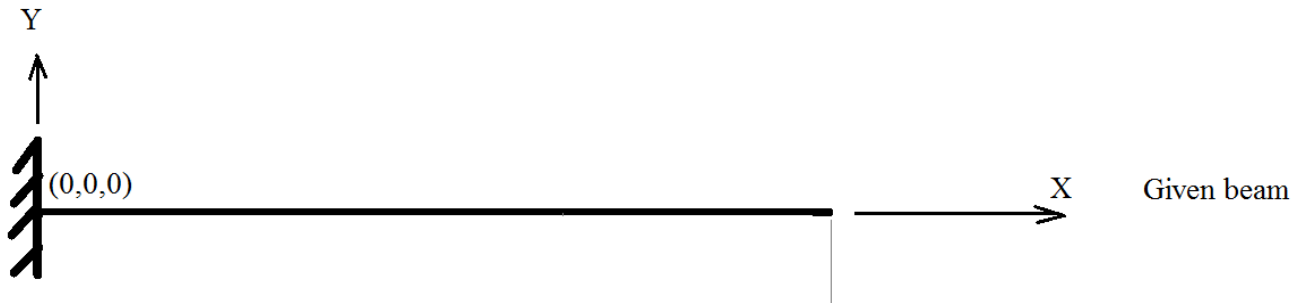

										FE model with Node no.s, Element No.s, BCs
										Applied loads & reactions
										Displacement plot
										Shear force diagram
										Bending moment diagram

Solution from Strength of Materials:

* From SOM , calculate Theoretical Maximum, Bending stress Maximum. Also write SFD & BMD diagram (**SFD5, SFD18, BMD2, BMD15**)

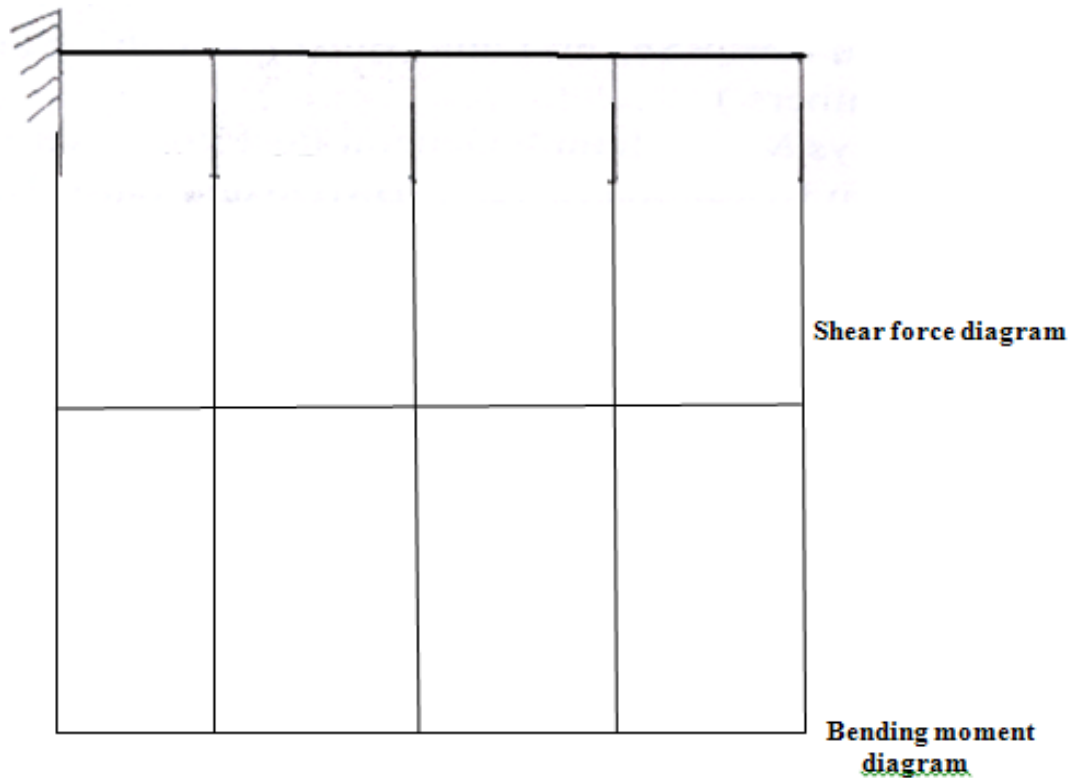

30. a) Effect of Self Weight on a Cantilever Beam. The beam is to be made of steel with a modulus of elasticity of 200 GPa. $L=1000\text{mm}$, $W=10\text{mm}$, $h=50\text{mm}$. Density= 7860 Kg/m^3 .

Compare and explain the influence of moment of Inertia on deflection and stresses with that of problem 30. Is there any change in SFD and BMD?

Sl. No.	Particular	Maximum value with units	Maximum value from problem 30	remarks
1	Moment of inertia			
2	Deflection			
3	Stress			
4	Shear force			
5	Bending moment			

Problem 31: Draw the shear force and bending moment diagram for the simply supported beam shown in figure. Also find maximum deflection and location. The beam is of rectangular cross section with depth 200 mm and width 120 mm. Find maximum bending stress and location. $E=2e5 \text{ N/mm}^2$, $\nu=0.3$

Given sketch

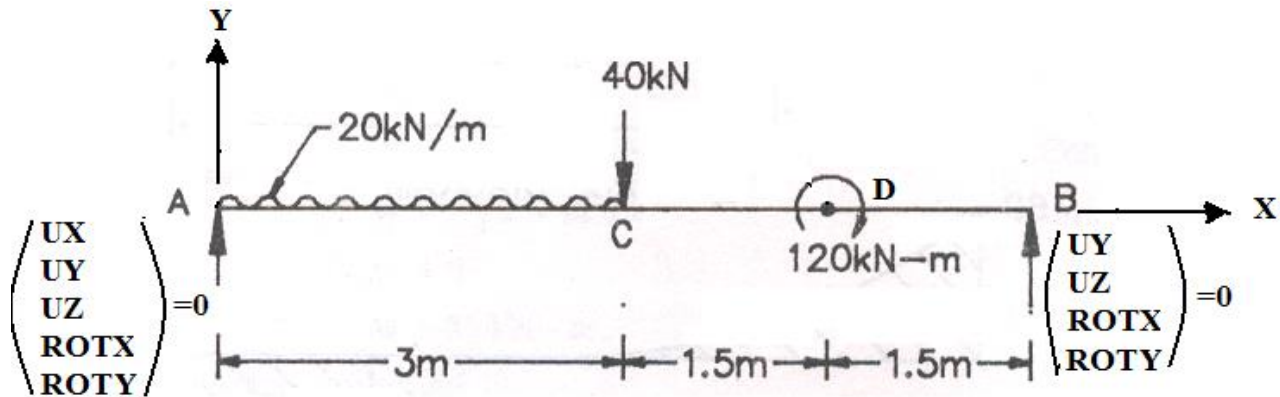

In ANSYS

1. Define the Type of Element: Preprocessor > Element Type > Add/Edit/Delete > Beam > 3D Finite Strain > Ok > Options > K3 > select **Cubic Form.** > Ok
2. Define Element Material Properties: Preprocessor > Material Props > Material Models > Structural > Linear > Elastic > Isotropic > EX=2e5, PRXY=0.3
3. Define cross sectional Area: Preprocessor > Sections > Beam > Common Sections > Sub-type > Rectangle > B=120, H=200 > Ok
4. Create geometric model:
 Preprocessor > Modeling > Create > Key points > In active CS >
 X=0, Y=0, Z=0 > Apply >
 X= 3000, Y=0, Z=0 > Apply >
 X= 4500, Y=0, Z=0 > Apply >
 X= 6000, Y=0, Z=0 > Apply >
 X=0, Y=1000, Z=0 > OK (This KP is **ORIENTATION KEYPOINT** - for orienting the beam cross section)
 PlotCtrls > Numbering > Tick "ON" Keypoint Numbers > OK
 Plot > Multiplot (for plotting all entities together)
5. Preprocessor > Modeling > Create > Lines > Lines > Straight line > Pick KPs 1 & 2 > Pick KPs 2 & 3 > Pick KPs 3 & 4 > OK
 PlotCtrls > Numbering > Tick "ON" Line Numbers > OK
6. Preprocessor > Meshing > Mesh Attributes > All lines > Tick 'YES' in Pick **Orientation Keypoint(s)** > Ok > Pick KP 5 - **Orientation Keypoint** > OK
7. Preprocessor > Meshing > Size Cntrls > Manual size > Lines > Picked lines > Pick line L1 > Set No. of element divisions = 6 > Apply > Pick the lines L2 and L3 > OK > Set No. of element divisions = 1 > OK
8. Preprocessor > Mesh > Lines > Pick all
 PlotCtrls > Numbering > Tick "OFF" Line Numbers & Keypoint Numbers > OK
 PlotCtrls > Style > Size and Shape > Display of element = ON > OK

Solution Phase: Assigning Loads and Solving

9. Preprocessor > Loads > Define Loads > apply > Structural Displacement > On Nodes > Pick starting node > Ok > Select **UX,UY,UZ, ROTX,ROTY** > Ok
10. Preprocessor > Loads > Define Loads > apply > Structural Displacement > On Nodes > Pick the last node > Ok > Select **UY,UZ ROTX,ROTY** > Ok
11. Preprocessor > loads > Define Loads > apply > Structural > Force/Moment > On Nodes > Pick Node no.2 > Ok > Select FY= -40000> OK
12. Preprocessor > loads > Define Loads > apply > Structural > Force/Moment > On Nodes > Pick Node no.14 > Ok > Select MZ= -120e6> OK
13. Preprocessor > loads > Define Loads > apply > Structural > Pressure > On beams > Click Box option > Drag a window selecting elements first 6 elements > Ok > **LKEY=1, VALI=20** > OK
14. Solution > Solve > Current LS > SOLVE > 'Solution is Done' > Close
15. General Post Processor > List Results > Nodal Solutions > DOF Solution > Displacement vector sum > OK > You will get a list as shown below:

```

PRINT U      NODAL SOLUTION PER NODE

***** POST1 NODAL DEGREE OF FREEDOM LISTING *****

LOAD STEP=   1   SUBSTEP=   1
TIME=   1.0000   LOAD CASE=   0

THE FOLLOWING DEGREE OF FREEDOM RESULTS ARE IN THE GLOBAL COORDINATE SYSTEM

      NODE      UX      UY      UZ      USUM
      1      0.0000      0.0000      0.0000      0.0000
      2      0.0000     -9.2082      0.10497E-23      9.2082
      3      0.0000     -2.8936      0.11595E-24      2.8936
      4      0.0000     -5.4781      0.37870E-24      5.4781
      5      0.0000     -7.5190      0.67662E-24      7.5190
      6      0.0000     -8.8600      0.92061E-24      8.8600
      7      0.0000     -9.4231      0.10524E-23      9.4231
     14      0.0000     -6.1861      0.48126E-24      6.1861
     16      0.0000      0.0000      0.0000      0.0000

MAXIMUM ABSOLUTE VALUES
NODE      0      7      7      7
VALUE     0.0000     -9.4231      0.10524E-23      9.4231

```

16. General Post Processor > List Results > Nodal Solutions > DOF Solution > Rotation vector sum > OK >

```

PRINT ROT    NODAL SOLUTION PER NODE

***** POST1 NODAL DEGREE OF FREEDOM LISTING *****

LOAD STEP=   1   SUBSTEP=   1
TIME=   1.0000   LOAD CASE=   0

THE FOLLOWING DEGREE OF FREEDOM RESULTS ARE IN THE GLOBAL COORDINATE SYSTEM

      NODE      ROTX      ROTY      ROTZ      RSUM
      1      0.0000      0.0000     -0.58722E-02      0.58722E-02
      2      0.62179E-14      0.13525E-27      0.11590E-02      0.11590E-02
      3      0.21367E-14     -0.41525E-27     -0.55467E-02      0.55467E-02
      4      0.40510E-14     -0.59186E-27     -0.46743E-02      0.46743E-02
      5      0.55450E-14     -0.56480E-27     -0.34113E-02      0.34113E-02
      6      0.64624E-14     -0.38827E-27     -0.19139E-02      0.19139E-02
      7      0.67009E-14     -0.13013E-27     -0.33839E-03      0.33839E-03
     14      0.33601E-14      0.49081E-27      0.15106E-02      0.15106E-02
     16      0.0000      0.0000      0.53778E-02      0.53778E-02

MAXIMUM ABSOLUTE VALUES
NODE      7      4      1      1
VALUE     0.67009E-14     -0.59186E-27     -0.58722E-02      0.58722E-02

```

* The above values are in radians

17. General Post Processor > Plot Results > Deformed Shape > Select Def + Undeformed > OK (Blue line indicates deformed shape and white line indicates original shape
Carry out animation also: Plot Ctrl's > Animate > Deformed Shape > Def+undeformed > Ok
18. General Post Processor > List Results > Reaction Solutions> all items >OK > note down the values. Check for equilibrium

REACTION SOLUTIONS in Newton

PRINT REACTION SOLUTIONS PER NODE

***** POST1 TOTAL REACTION SOLUTION LISTING *****

LOAD STEP= 1 SUBSTEP= 1
TIME= 1.0000 LOAD CASE= 0

THE FOLLOWING X,Y,Z SOLUTIONS ARE IN THE GLOBAL COORDINATE SYSTEM

NODE	FX	FY	FZ	MX	MY	MZ
1	0.0000	45000.	-0.57371E-20	-0.24119E-04	0.65484E-10	
16		55000.	-0.22929E-20	-0.12753E-04	-0.24011E-09	

TOTAL VALUES
VALUE 0.0000 0.10000E+06 -0.80300E-20 -0.36872E-04 -0.17462E-09 0.0000

19. General post processor > Element table > Define table > Add > set user label for item = **SFD5**, select item, comp, results data item = by sequence number- select **SMISC, 5** (Type 5 after selecting SMISC) > Apply > set user label for item = **SFD18**, select item, comp, results data item = by sequence number- select **SMISC, 18** (Type 18 after selecting SMISC) > Apply > set user label for item = **BMD2**, select item, comp, results data item = by sequence number- select **SMISC,2** (Type 2 after selecting SMISC) > Apply > set user label for item = **BMD15**, select item, comp, results data item = by sequence number- select **SMISC, 15** (Type 15 after selecting SMISC) > Apply > OK > Close
20. General Post Processor > Element Table > List
Element Table > Select **SFD5, SFD18, BMD2, BMD15** > OK > Note the shear Forces and Note the Bending Moments

PRINT ELEMENT TABLE ITEMS PER ELEMENT

***** POST1 ELEMENT TABLE LISTING *****

STAT ELEM	CURRENT SFD5	CURRENT SFD18	CURRENT BMD2	CURRENT BMD15
1	-45000.	-35000.	-0.61467E-06	-0.20000E+08
2	-35000.	-25000.	-0.20000E+08	-0.35000E+08
3	-25000.	-15000.	-0.35000E+08	-0.45000E+08
4	-15000.	-5000.0	-0.45000E+08	-0.50000E+08
5	-5000.0	5000.0	-0.50000E+08	-0.50000E+08
6	5000.0	15000.	-0.50000E+08	-0.45000E+08
7	55000.	55000.	-0.45000E+08	0.37500E+08
8	55000.	55000.	-0.82500E+08	-0.62212E-06

MINIMUM VALUES
ELEM 1 1 8 5
VALUE -45000. -35000. -0.82500E+08 -0.50000E+08

MAXIMUM VALUES
ELEM 7 7 1 7
VALUE 55000. 55000. -0.61467E-06 0.37500E+08

21. General Post Processor > Plot Results > contour plot > Line element res> Select **SFD5, SFD18**, > OK > SFD will be displayed

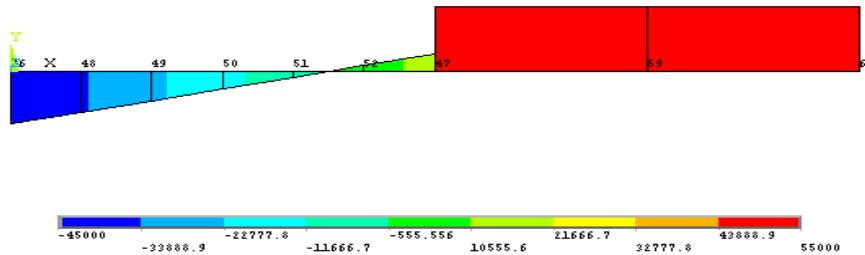
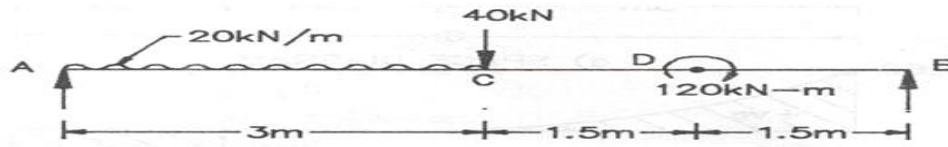

22. General Post Processor >Plot Results > contour plot > Line element res>Select **BMD2**, **BMD15**, > OK > BMD will be displayed

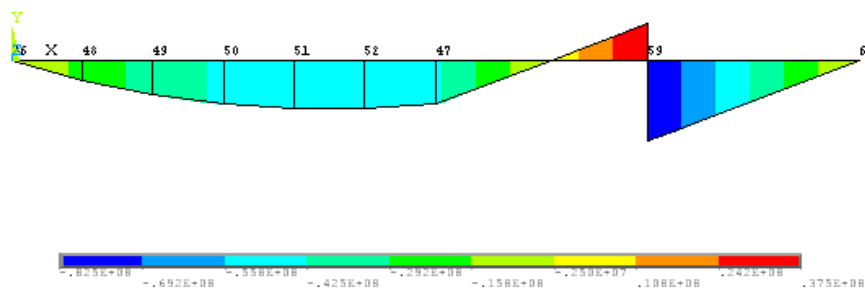

To find the maximum and minimum bending stresses in MPa:

Element table definition for maximum stress (generally top fibre)

SMAXL -Element left side SMISC34, SMAXR - Element right side SMISC39,

Element table definition for minimum stress (generally bottom fibre),

SMINL-element left side SMISC35, SMINR -Element right side SMISC40

PRINT ELEMENT TABLE ITEMS PER ELEMENT

***** POST1 ELEMENT TABLE LISTING *****

STAT ELEM	CURRENT SMIS34	CURRENT SMIS39	CURRENT SMIS35	CURRENT SMIS40
1	-0.76834E-12	-25.000	0.76834E-12	25.000
2	-25.000	-43.750	25.000	43.750
3	-43.750	-56.250	43.750	56.250
4	-56.250	-62.500	56.250	62.500
5	-62.500	-62.500	62.500	62.500
6	-62.500	-56.250	62.500	56.250
7	-56.250	46.875	56.250	-46.875
8	-103.13	-0.77765E-12	103.13	0.77765E-12

MINIMUM VALUES

ELEM	8	5	1	7
VALUE	-103.13	-62.500	0.76834E-12	-46.875

MAXIMUM VALUES

ELEM	1	7	8	5
VALUE	-0.76834E-12	46.875	103.13	62.500

NOTE: $\sigma_{bmax} = \frac{M_{max} Y}{I} = \frac{82.5 \times 10^6 \times 100 \times 12}{120 \times 200^3} = 103.13 \text{ MPa}$

120×200^3

SOM solution for Problem 31

Draw the shear force and bending moment diagram for the beam shown in figure. Also find maximum deflection and location. The beam is of rectangular cross section with depth 200 mm and width 120 mm. Find maximum bending stress and location.

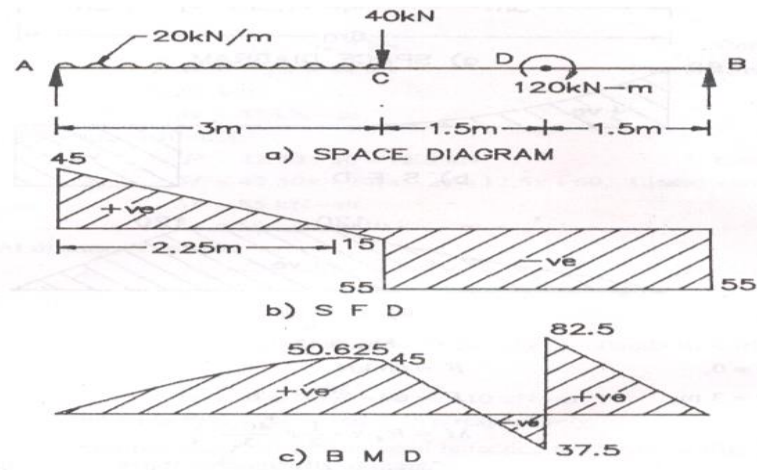

$$\sum M_B = 0$$

gives $R_A \times 6 - 20 \times 3(3 + 1.5) - 40 \times 3 + 120 = 0$

$$R_A = 45 \text{ kN.}$$

$$\therefore R_B = 20 \times 3 + 40 - 45 = 55 \text{ kN.}$$

Portion AC : Measuring x from A

$$F = R_A - Wx = 45 - 20x \quad \text{Linear variation}$$

At $x = 0$, $F = 45 \text{ kN.}$

At $x = 3 \text{ m.}$, $F = 45 - 20 \times 3 = -15 \text{ kN.}$

$$F = 0 \text{ at } x = 2.25 \text{ m}$$

where x is given by $0 = 45 - 20x$

or $x = 2.25 \text{ m.}$

$$M = R_A x - \frac{Wx^2}{2}$$

$$= 45x - \frac{20x^2}{2} = 45x - 10x^2. \quad \text{Parabolic variation}$$

At $x = 0$, $M = 0.$

At $x = 3 \text{ m.}$, $M = 45 \times 3 - 10 \times 3^2 = 45 \text{ kN-m.}$

Moment is maximum where shear force is zero i.e., at $x = 2.25 \text{ m.}$

$$\therefore M_{\max} = 45 \times 2.25 - 10 \times 2.25^2 = 50.625 \text{ kN-m.}$$

Portion CD : Measuring x from A,

$$F = 45 - 20 \times 3 - 40 = -55 \text{ kN.} \quad \text{Constant}$$

$$M = 45x - 20 \times 3(x - 1.5) - 40(x - 3)$$

$$= -55x + 210, \quad \text{Linear variation}$$

At $x = 3 \text{ m.}$, $M = -55 \times 3 + 210 = 45 \text{ kN-m}$

At $x = 4.5 \text{ m}$, $M = -55 \times 4.5 + 210 = -37.5 \text{ kN-m.}$

Portion DB : Measuring x from B,

$$F = -R_B = -55 \text{ kN,} \quad \text{Constant}$$

$$M = R_B x = 55x \quad \text{Linear variation}$$

At $x = 0$, $M = 0.$

At $x = 1.5 \text{ m.}$, $M = 55 \times 1.5 = 82.5 \text{ kN-m.}$

\therefore SFD and BMD are as shown

Problem32: Draw the shear force and bending moment diagram for the following problem. Also determine displacement field, Maximum bending stress, and reactions by taking it as a Rectangular c/s with depth 20 mm and thickness 10mm. Take $\nu = 0.3$, $E = 2 \times 10^5 \text{ N/mm}^2$.

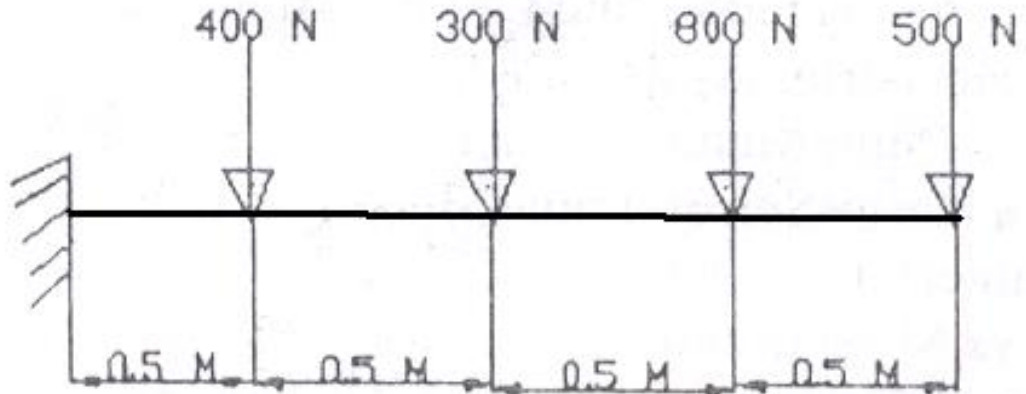

Results:

ELEMENTAL SOLUTION- Shear Force and Bending Moment (Mention the units also)

Element No.	Shear Forces on Elements		Bending Moment Values	
	SFD5	SFD18	BMD2	BMD15
1				
2				
3				
4				

Results: ELEMENTAL SOLUTION-Bending Stresses

Element No.	Bending Stresses			
	SMAXL34	SMAXR39	SMINL 35	SMINR 40
1				
2				
3				
4				

Max stress: _____ Location: _____

Max deflection: _____ Location: _____

Slope at tip: _____

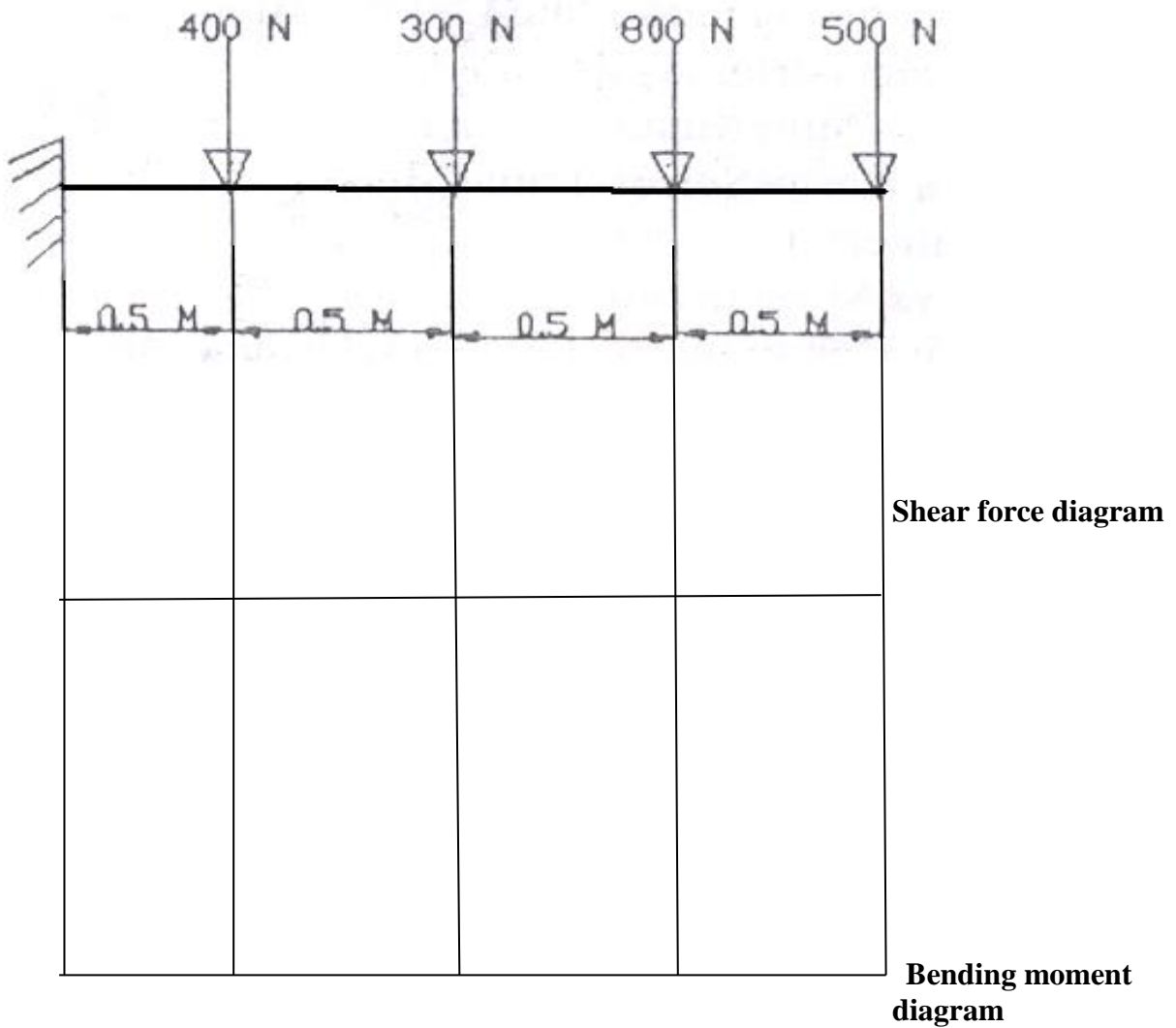

Compare solutions from SOM. Also find deflections using SOM approach.

Problem33: Find the shear force and bending moments and draw diagrams for the following problem. Data: Rectangular c/s depth 120 mm, thickness 10mm, $\nu = 0.3$, $E = 2 \times 10^5 \text{ N/mm}^2$ Also determine displacement field, Maximum bending stress, and reactions.

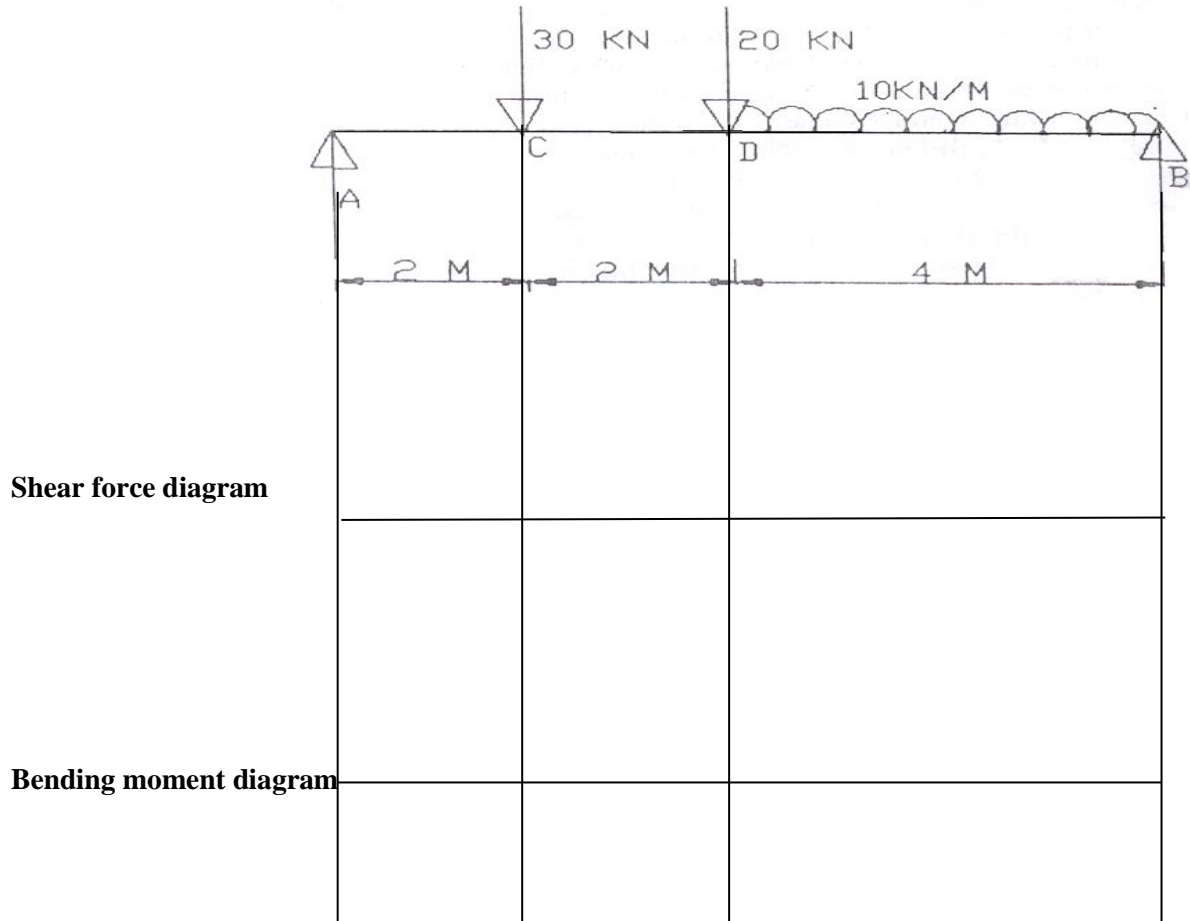

Shear force diagram

Bending moment diagram

Results: ELEMENTAL SOLUTION- Shear Force and Bending Moment:

Element No.	Shear Forces on Elements		Bending Moment Values	
	SFD5	SFD18	BMD2	BMD15
1				
2				
3				
4				
5				
6				
7				
8				
9				
10				
11				
12				

Results: ELEMENTAL SOLUTION- Bending stresses

Element No.	Bending stresses			
	SMAXL34	SMAXR39	SMINL 35	SMINR 40
1				
2				
3				
4				
5				
6				
7				
8				
9				
10				
11				
12				

Also obtain maximum stress, maximum deflection and locations

Problem 34: A long cantilever beam with 30 mm square cross-section and 1000 mm length (see figure below) is subjected to

- (a) Concentrated tip force
 - (b) Concentrated tip moment
 - (c) Distributed pressure load
- Each loading is applied separately.

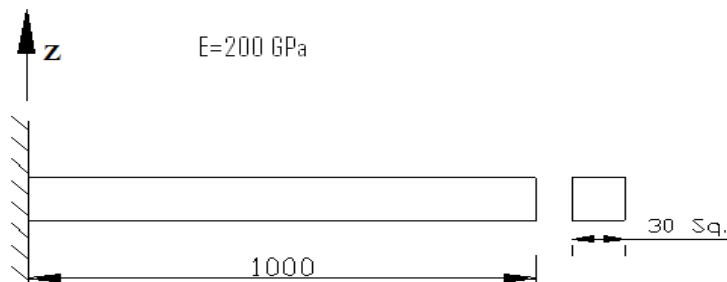

Loading	Deflection (mm)		Bending Moment (N-mm)		Max. Bending Stress (N/mm ²)	
	ANSYS	Theory	ANSYS	Theory	ANSYS	Theory
Case A $F=10\text{KN}$						
Case B $M=10\text{KN-m}$						
Case C $P=5\text{MPa}$						

Problem 35: A long cantilever beam with 30 mm square cross-section and 1000 mm length is subjected to an off-centered axial force of 1000 N (see figure below). The force is offset by 100 mm. $E=70\text{GPa}$

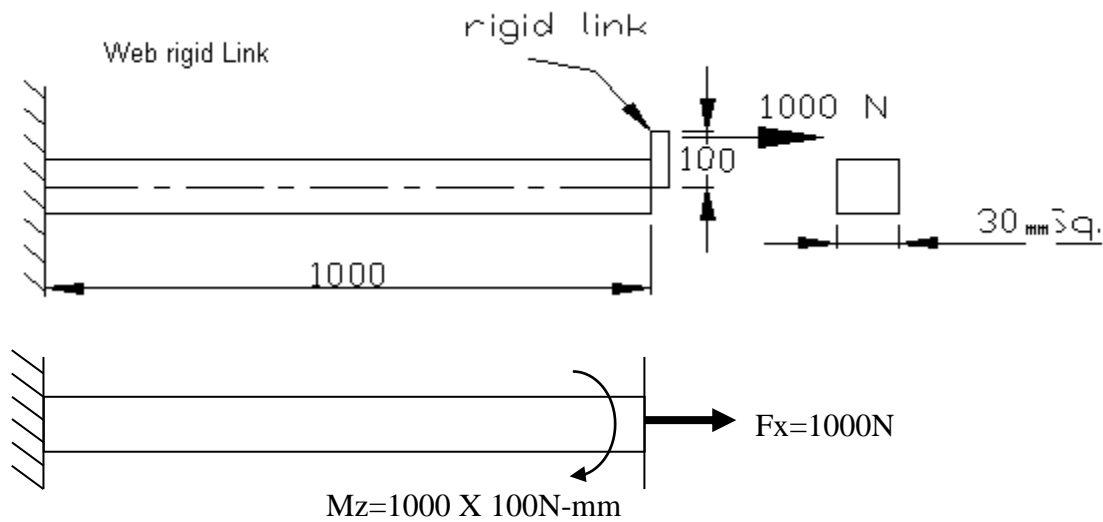

Result	Node No.	Deflection (mm)	Node No.	Bending Moment (N-mm)	Element No.	Max. Bending Stress (N/mm ²)
ANSYS Analysis						
Theory						

Problem 36: Determine the end forces of a clamped-clamped beam due to a 25 mm settlement at the right end. Take 10 Elements

$A = 50 \times 50 \text{ Sq.}$

$E = 200 \text{ Gpa}$

$L = 2 \text{ m}$

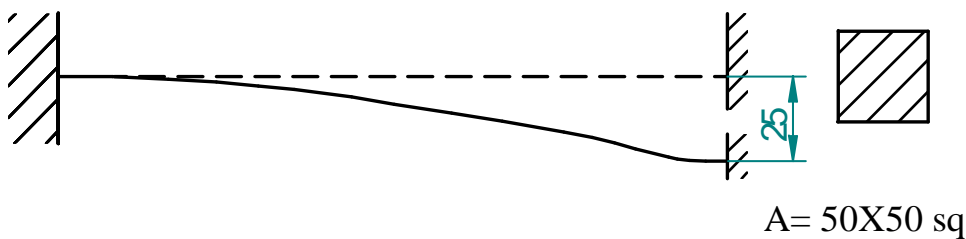

Reactions:

Result	Node No.	Deflection (mm)	Node No.	Bending Moment (N-mm)	Element No.	Max. Bending Stress (N/mm ²)	Max. Stress (N/mm ²)	Minimum Stress (N/mm ²)
ANSYS Analysis								
Theory								

Problem 37: Determine the end forces of a clamped-clamped beam due to a 1 radian imposed rotation at the right end.

A = 50 X 50 Sq.

E = 200 Gpa

l = 2 m

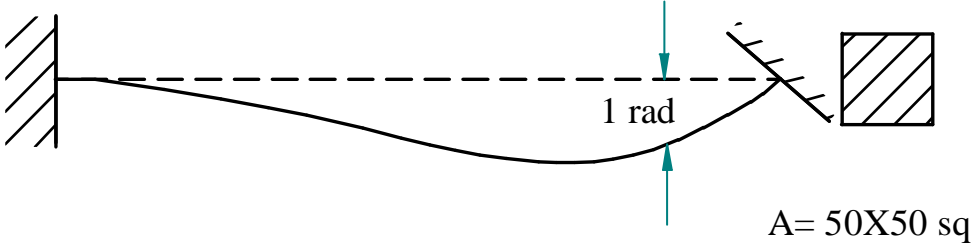

Result	Node No.	Deflection (mm)	Node No.	Bending Moment (N-mm)	Element No.	Max. Bending Stress (N/mm ²)	Max. Stress (N/mm ²)	Minimum Stress (N/mm ²)
ANSYS Analysis								
Theory								

Problem 38: A beam of length L and height h is built-in at one end and loaded at free end with (A) a shear force F , and (B) a moment M . Determine the deflection at the free end.

$A = 50 \times 50$ Sq.

$E = 200$ Gpa

$L = 2$ m

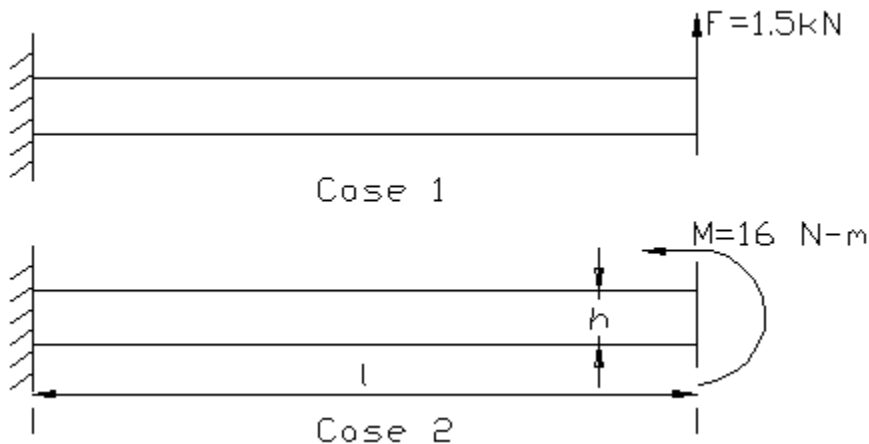

Result	Node No.	Deflection (mm)	Node No.	Bending Moment (N-mm)	Element No.	Max. Bending Stress (N/mm ²)	Max. Stress (N/mm ²)	Minimum Stress (N/mm ²)
ANSYS Analysis								
Theory								

Problem 39: The figure shows a loaded beam subjected to various types of loading $E = 200$ GPa , $I = 4 \times 10^6$ mm⁴

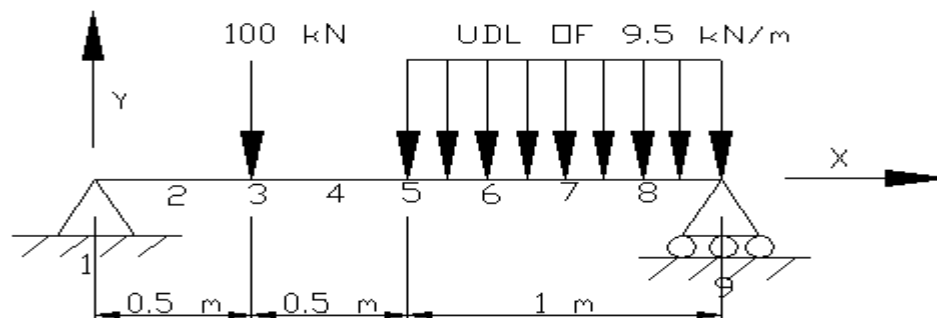

Result	Max Deflection (mm)	Node No.	Bending Moment (N-mm)	Element No.	Max. Bending location (N/mm ²)	Bending Stress
ANSYS Analysis						
Theory						

Hint: Assume it as a square cross section; calculate the dimension from the given value of moment of inertia

Problem 40: A long cantilever beam has an I cross section with a total depth of 150mm, flange width of 100mm, thickness of flange and web being 25mm. Length of the beam is 1000 mm (see figure below) and is subjected to

- (a) Concentrated tip force
- (b) Concentrated tip moment
- (c) Distributed pressure load.

Each loading is applied separately

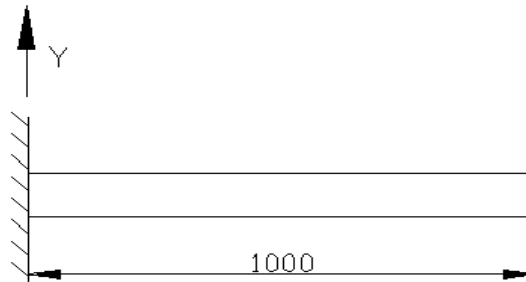
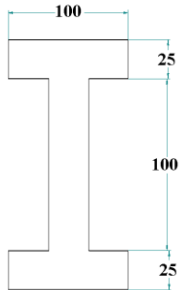

A=

Loading	Deflection (mm)		Bending Moment (N-mm)		Max. Bending Stress (N/mm ²)	
	ANSYS	Theory	ANSYS	Theory	ANSYS	Theory
Case A F=10KN						
Case B M=10KN-m						
Case C P=5MPa						

Problem 41: Draw the shear force and bending moment diagram for the beam shown in figure. Also find maximum deflection and location .The beam is of rectangular cross section with depth 300 mm and width 200 mm. Find maximum stress and location. $E = 200\text{GPa}$.

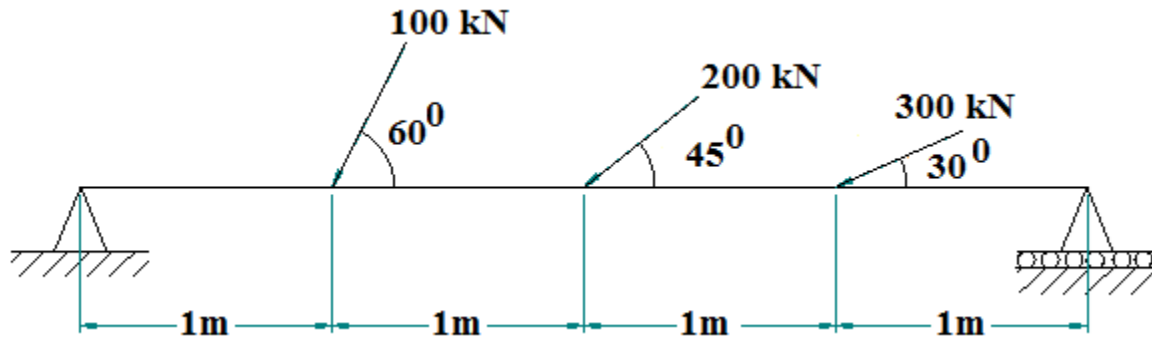

Results: ELEMENTAL SOLUTION- Shear Force and Bending Moment, and Axial thrust

Element No.	Shear Forces on Elements		Bending Moment Values		Axial thrust	
	SFD5	SFD18	BMD2	BMD15	Mforx1(SMISC,1)	Mforx7(SMISC,14)
1						
2						
3						
4						

Results: ELEMENTAL SOLUTION- stresses

Element No.	stresses			
	SMAXL	SMAXR	SMINL	SMINR
1				
2				
3				
4				

Also obtain maximum stress, maximum deflection and their locations

Problem 42: Draw the shear force and bending moment diagram for the beam shown in figure. Also find maximum deflection and location. Cross section is I with a total depth of 150mm, flange width of 100mm, thickness of flange and web being 25mm. Find maximum stress and location. $E = 200\text{GPa}$.

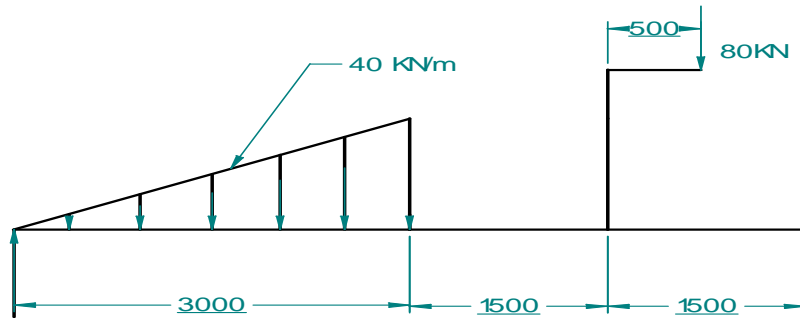

Results: ELEMENTAL SOLUTION- Shear Force and Bending Moment:

Element No.	Shear Forces on Elements		Bending Moment Values	
	SFD5	SFD18	BMD2	BMD15
1				
2				
3				
4				
5				
6				
7				
8				
9				
10				
11				
12				

Results: ELEMENTAL SOLUTION- Bending stresses

Element No.	Bending stresses			
	SMAXL	SMAXR	SMINL	SMINR
1				
2				
3				
4				
5				
6				
7				
8				
9				
10				
11				
12				

Also obtain maximum stress, maximum deflection and their locations

Problems on TORSION of shafts

Problem 43: A Stepped shaft is subjected to torque as shown in fig. Determine the angle of twist at the free end and twist in each portion in degrees. Also find the maximum shear stress in each step. Young's modulus=208GPa, Poisson's ratio=0.3

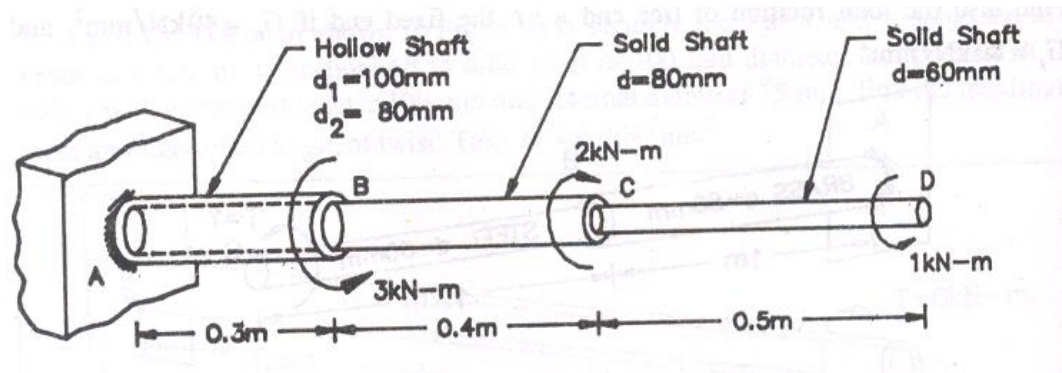

Case a) Procedure for BEAM model:

Tabulate the node-coordinate data.

Node No	Coordinate		
	X (mm)	Y (mm)	Z (mm)
1	0	0	0
2	300	0	0
3	700	0	0
4	1200	0	0

1. Preferences > structural > Ok
2. Preprocessor > ELEMENT type > Add/edit/delete > add > **Beam- 3D finite strain** > OK > CLOSE
3. Preprocessor > Material Props >Material Model >Structural > Elastic>Isotropic> EX=208GPa, PRXY=0.3>OK
4. Preprocessor > Section > Beam >Common Sections.
On the **beam Tool** dialog box, enter '1' for ID, '**Section1**' for Name, Choose **Hollow Cross-Section** for Sub-Type, enter $R_i=40$, $R_o=50$ Apply.
5. On the **beam Tool** dialog box, enter '2' for ID, '**Section2**' for Name, Choose **Circular Solid Cross-Section** for Sub-Type, Enter $R=40$, Apply .
6. On the **beam Tool** dialog box, enter '3' for ID, '**Section3**' for Name, Choose **Circular Solid Cross-Section** for Sub-Type, enter $R=30$, ok.
7. Preprocessor >Modeling> Create > Nodes > In active CS >
Node No:=1, X=0, Y=0, Z=0 > Apply
Node No:=2, X=300, Y=0, Z=0 > Apply
Node No:=3, X=700, Y=0, Z=0 > Apply
Node No:=4, X=1200,Y=0, Z=0 > OK
8. Preprocessor > Modeling > Create > elements >Element Attributes> Section number>**Section1**>OK
9. Preprocessor > Modeling > Create > elements Thru Nodes > 1 & 2 nodes > OK
10. Preprocessor > Modeling > Create > elements >Element Attributes>Section number> **Section2**>OK
11. Preprocessor > Modeling > Create > elements Thru Nodes > Pick 2 & 3 nodes > OK

12. Preprocessor > Modeling > Create > elements >Element Attributes>Section number>**Section3**>OK
13. Preprocessor > Modeling > Create > elements Thru Nodes > Pick 3 & 4 nodes > OK
14. Utility Menu > PlotCtrls>Style>Size and Shape > On **Size and Shape** dialog box turn **ON** [/ESHAPE] display of Element and click **OK**.
15. In the Utility Menu, select Plot> Elements.
16. Switch to isometric view using the **pan-Zoom-Rotate** dialog box.
17. Preprocessor>Loads>DefineLoads>Apply>Structural> Displacement> On Nodes>select **Node1**>OK>**ALLDOF**>OK
18. Preprocessor>Loads>DefineLoads>Apply>Structural> Force/Moment> On Nodes>select **Node2**>OK>Direction of force/mom=**MX**, Value=**3e6**>Apply
19. Preprocessor>Loads>DefineLoads>Apply>Structural>Force/Moment > On Nodes>select **Node3**>OK>Direction of force/mom=**MX**, Value=**-2e6**>Apply
20. Preprocessor>Loads>DefineLoads>Apply>Structural>Force/Moment >On Nodes>select **Node4**>OK>Direction of force/mom=**MX**, Value=**1e6**>OK
21. Solution>Solve>Current LS>OK, **Close Solution Done Window**.

RESULTS:

Nodal solution:

22. General Postproc>Plot result>Contour Plot>NodalSolu.

On the Contour Nodal Solution Data dialog box, Nodal solution>DOF Solution> Select Rotation vector sum>OK

23. General postprocessor>List Results>Nodal Solutions>OK>DOF Solution>Rotation vector sum>OK (in radians)

THE FOLLOWING DEGREE OF FREEDOM RESULTS ARE IN THE GLOBAL COORDINATE SYSTEM

NODE	ROTX	ROTY	ROTZ	RSUM
1	0.0000	0.0000	0.0000	0.0000
2	0.12939E-02	0.0000	0.0000	0.12939E-02
3	0.50545E-04	0.0000	0.0000	0.50545E-04
4	0.49627E-02	0.0000	0.0000	0.49627E-02

MAXIMUM ABSOLUTE VALUES

NODE	4	0	0	4
VALUE	0.49627E-02	0.0000	0.0000	0.49627E-02

Reaction solution:

24. General Postproc>List results>Reaction Solution>All Items>OK

THE FOLLOWING X,Y,Z SOLUTIONS ARE IN THE GLOBAL COORDINATE SYSTEM

NODE	FX	FY	FZ	MX	MY	MZ
1	0.0000	0.46101E-11	0.21918E-11	-0.20000E+07	-0.32876E-09	0.69151E-09

TOTAL VALUES

VALUE	0.0000	0.46101E-11	0.21918E-11	-0.20000E+07	-0.32876E-09	0.69151E-09
-------	--------	-------------	-------------	--------------	--------------	-------------

Element Solution:

25. General post processor > Element table > Define table > Add > set user label for item = **TQ4**, select item, comp, results data item = by sequence number- select **SMISC, 4** (Type 4 after selecting SMISC) > Apply > set user label for item = **TQ17**, select item, comp, results data item = by sequence

number- select **SMISC, 17** (Type 17 after selecting SMISC) > Apply > OK > Close

26. General Post Processor > Element Table > List Element Table > Select **TQ4, TQ17**>OK > Note the Torsional Moments in N-mm

STAT ELEM	CURRENT TQ4	CURRENT TQ17
1	0.20000E+07	0.20000E+07
2	-0.10000E+07	-0.10000E+07
3	0.10000E+07	0.10000E+07

MINIMUM VALUES	
ELEM	2
VALUE	-0.10000E+07

MAXIMUM VALUES	
ELEM	1
VALUE	0.20000E+07

27. General Post Processor > Plot results > Contour plot > Element Table > Select **TQ4, TQ17**>OK

NOTE: We can only find torsional moments as we are using BEAM element. We can get shear stresses in each portion by using PIPE288 element

Case b) Procedure for PIPE model:

1. Preferences > structural > Ok
2. Preprocessor > ELEMENT type > Add/edit/delete > add > **Pipe- 3D finite strain** > OK > Options > Hoop strain treatment = Thick shell > OK > CLOSE
3. Preprocessor > Material Props > Material Model > Structural > Elastic>Isotropic> EX=208GPa, PRXY=0.3>OK
4. Preprocessor > Section > Pipe >Add > Add pipe section with ID = 1, ok > Section name = **Section1, Pipe diameter = 100, Wall thickness = 10, Apply** > Add pipe section with ID = 2, ok > Section name = **Section2, Pipe diameter = 80, Wall thickness = 40, Apply** > Add pipe section with ID = 3, ok > Section name = **Section3, Pipe diameter = 60, Wall thickness = 30, Ok** (Close the warning message)
5. Preprocessor >Modeling> Create > Nodes > In active CS >
Node No:=1, X=0, Y=0, Z=0 > Apply
Node No:=2, X=300, Y=0, Z=0 > Apply
Node No:=3, X=700, Y=0, Z=0 > Apply
Node No:=4, X=1200, Y=0, Z=0 > OK
6. Preprocessor > Modeling > Create > elements >Element Attributes> Section number>**Section1**>OK
7. Preprocessor > Modeling > Create > elements Thru Nodes > 1 & 2 nodes > OK
8. Preprocessor > Modeling > Create > elements >Element Attributes>Section number>**Section2**>OK
9. Preprocessor > Modeling > Create > elements Thru Nodes > Pick 2 & 3 nodes > OK
10. Preprocessor > Modeling > Create > elements >Element Attributes>Section number>**Section3**>OK
11. Preprocessor > Modeling > Create > elements Thru Nodes > Pick 3 & 4 nodes > OK
12. Utility Menu > PlotCtrls>Style>Size and Shape > On **Size and Shape** dialog box turn **ON** [/ESHAPE] display of Element and click **OK**.
13. In the Utility Menu, select Plot> Elements.
14. Switch to isometric view using the **pan-Zoom-Rotate** dialog box.

15. Preprocessor>Loads>Define Loads> Apply> Structural> Displacement> On Nodes>select **Node1**>OK>**ALLDOF**>OK
16. Preprocessor>Loads>Define Loads> Apply> Structural> Force/Moment> On Nodes>select **Node2**>OK>Direction of force/mom=**MX**, Value= **3e6**>Apply
17. Preprocessor>Loads>Define Loads> Apply> Structural>Force/Moment > On Nodes>select **Node3**>OK>Direction of force/mom=**MX**, Value= **-2e6**>Apply
18. Preprocessor>Loads>Define Loads> Apply> Structural>Force/Moment >On Nodes>select **Node4**>OK>Direction of force/mom=**MX**, Value= **1e6**>OK
19. Solution>Solve>Current LS>OK, **Close Solution Done Window.**

20. General postprocessor>List Results>Nodal Solutions>OK>DOF Solution>Rotation vector sum>OK (in radians)

THE FOLLOWING DEGREE OF FREEDOM RESULTS ARE IN THE GLOBAL COORDINATE SYSTEM

NODE	ROTX	ROTY	ROTZ	RSUM
1	0.0000	0.0000	0.0000	0.0000
2	0.12939E-02	0.0000	0.0000	0.12939E-02
3	0.50545E-04	0.0000	0.0000	0.50545E-04
4	0.49627E-02	0.0000	0.0000	0.49627E-02

MAXIMUM ABSOLUTE VALUES				
NODE	4	0	0	4
VALUE	0.49627E-02	0.0000	0.0000	0.49627E-02

21. General Postproc>List results>Reaction Solution>All Items>OK

THE FOLLOWING X,Y,Z SOLUTIONS ARE IN THE GLOBAL COORDINATE SYSTEM

NODE	FX	FY	FZ	MX	MY	MZ
1	0.0000	0.46101E-11	0.21918E-11	-0.20000E+07	-0.32876E-09	0.69151E-09

TOTAL VALUES						
VALUE	0.0000	0.46101E-11	0.21918E-11	-0.20000E+07	-0.32876E-09	0.69151E-09

22. General post processor > Element table > Define table > Add > set user label for item = **TQ4**, select item, comp, results data item = by sequence number- select **SMISC, 4** (Type 4 after selecting SMISC) > Apply > set user label for item = **TQ17**, select item, comp, results data item = by sequence number- select **SMISC, 17** (Type 17 after selecting SMISC) > Apply > OK > Close

23. General Post Processor > Element Table > List Element Table > Select **TQ4, TQ17**>OK > Note the Torsional Moments in N-mm

STAT	CURRENT	CURRENT
ELEM	TQ4	TQ17
1	0.20000E+07	0.20000E+07
2	-0.10000E+07	-0.10000E+07
3	0.10000E+07	0.10000E+07

MINIMUM VALUES		
ELEM	2	2
VALUE	-0.10000E+07	-0.10000E+07

MAXIMUM VALUES		
ELEM	1	1
VALUE	0.20000E+07	0.20000E+07

24. General Post Processor > Plot results >Contour plot> Elemental Solu > Stress > XY shear stress >OK

Check with SOM solution:

PART-B

Chapter 08: 2D Analysis

Plate Problems

Plane Stress

Plane stress is defined to be a state of stress in which the normal stress and the shear stresses directed perpendicular to the plane are assumed to be zero. That is, the normal stress σ_z and the shear stresses τ_{xz} and τ_{yz} are assumed to be zero. Generally, members that are thin (those with a small z dimension compared to the in-plane x and y dimensions) and whose loads act only in the x - y plane can be considered to be under plane stress.

Examples: Thin Plate with a hole subjected to in plane loading, rotating disk or flywheel

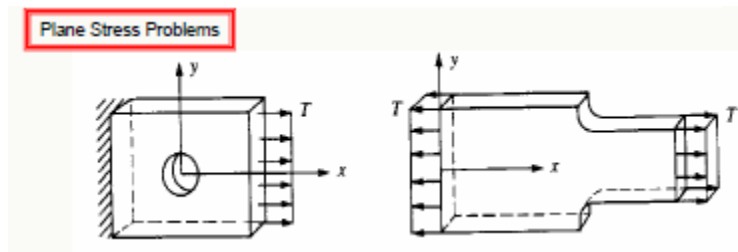

Plane Strain

Plane strain is defined to be a state of strain in which the strain normal to the x - y plane ϵ_z and the shear strains γ_{xz} and γ_{yz} are assumed to be zero. The assumptions of plane strain are realistic for long bodies (say, in the z direction) with constant cross-sectional area subjected to loads that act only in the x and/or y directions and do not vary in the z direction.

Examples: wall of a dam, Strip footing, rotating shaft or cylinder

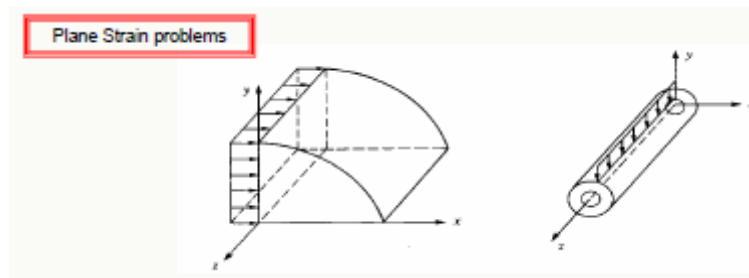

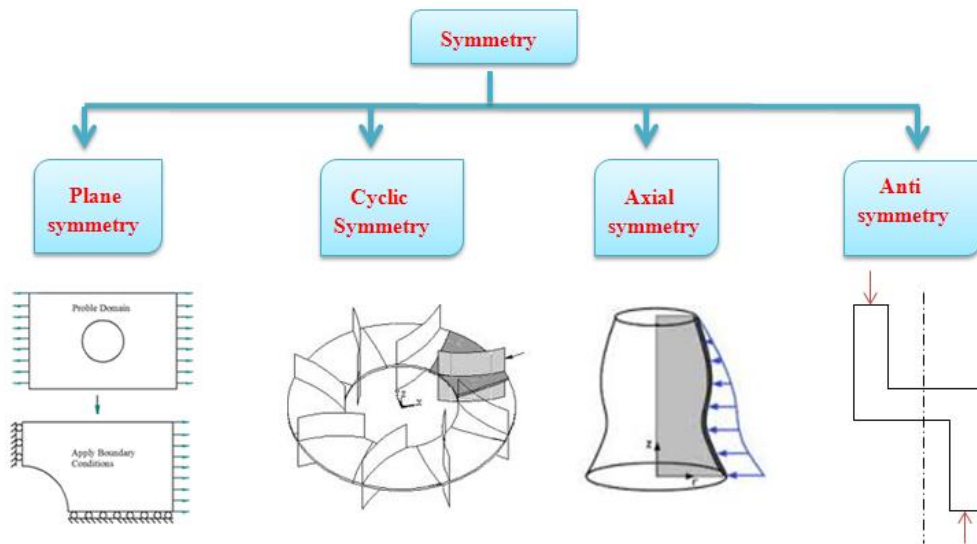
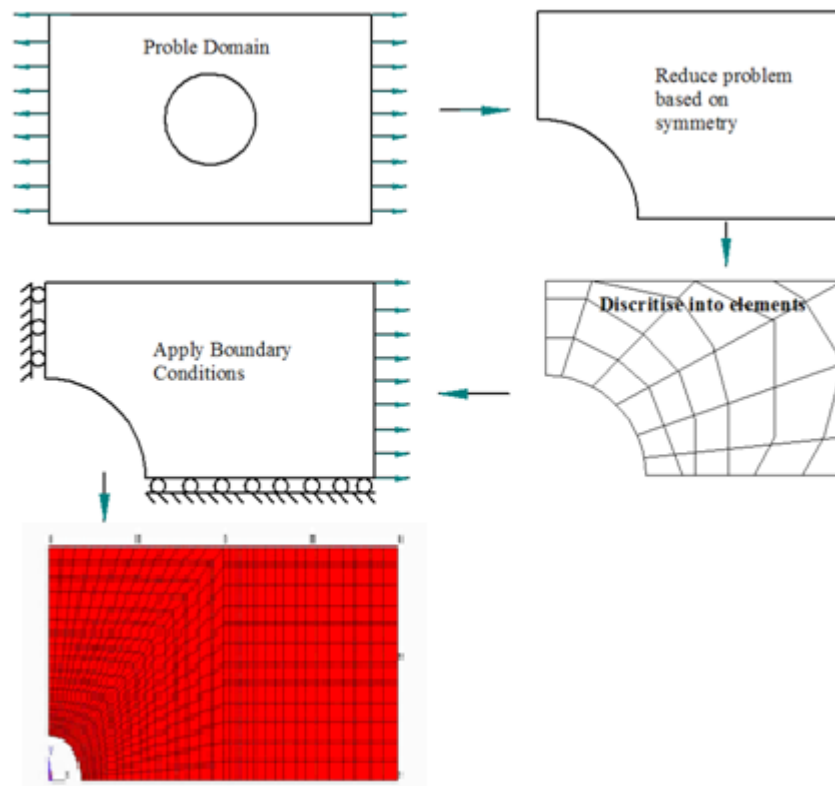

Plate with a hole: Can be solved as Bi-axial symmetry problem, as shown below



PLANE182 Element Description: 2-D 4-Node Structural Solid

PLANE182 is used for 2-D modeling of solid structures. The element can be used as either a plane element (plane stress, plane strain or generalized plane strain) or an axisymmetric element. It is defined by four nodes having two degrees of freedom at each node: translations in the nodal x and y directions. The element has plasticity, hyperelasticity, stress stiffening, large deflection, and large strain capabilities. It also has mixed formulation capability for simulating deformations of nearly incompressible elastoplastic materials, and fully incompressible hyperelastic materials.

PLANE182 Geometry

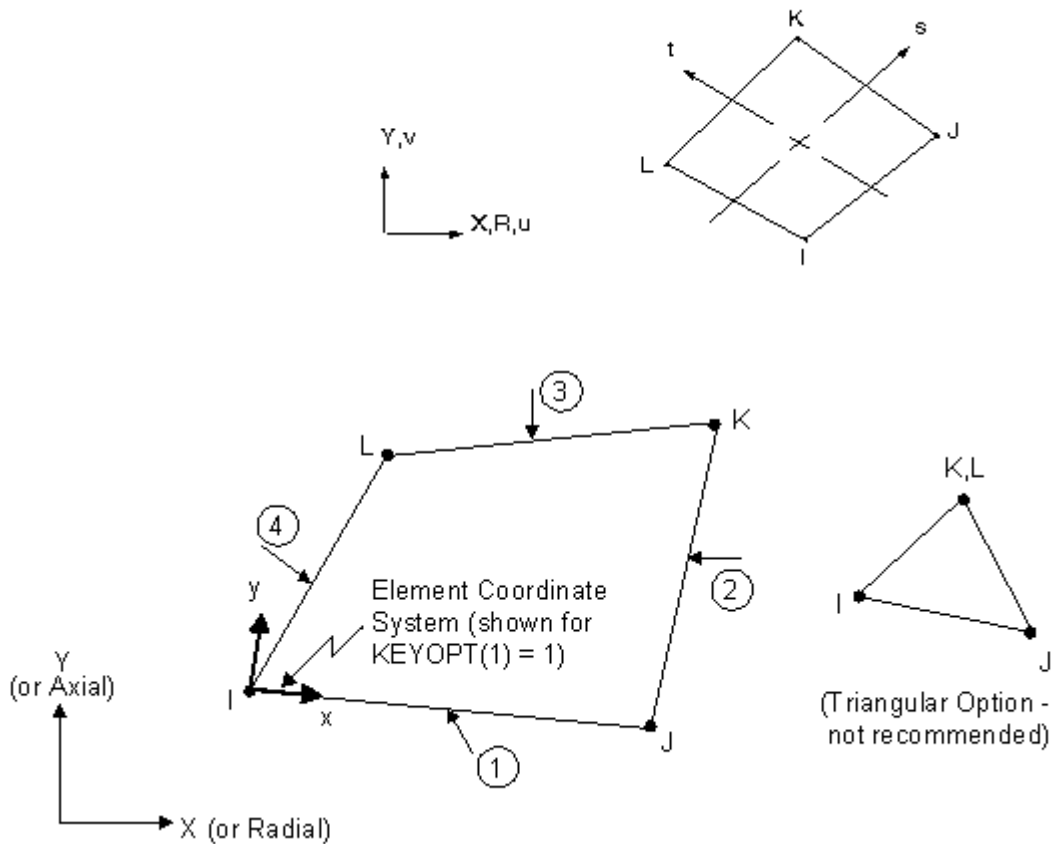

Meshing – An important step:

Meshing is a three-step procedure:

- Define element attributes
- Specify mesh controls
- Generate the mesh

Free meshing v/s Mapped Meshing:

Free Mesh

- + Easy to create; no need to divide complex shapes into regular shapes.
- Volume meshes can contain only tetrahedra, resulting in a large number of elements.
- Only higher-order (10-node) tetrahedral elements are acceptable, so the number of DOF can be very high.

Mapped Mesh

- + Generally contains a lower number of elements.
- + Lower-order elements may be acceptable, so the number of DOF is lower.
- + Aesthetically pleasing.
- Areas and volumes must be “regular” in shape, and mesh divisions must meet certain criteria.
- Very difficult to achieve, especially for complex shaped volumes.

- There are two main meshing methods: *free* and *mapped*.

- **Free Mesh**

- Has no element shape restrictions.
- The mesh does not follow any pattern.
- Suitable for complex shaped areas and volumes.

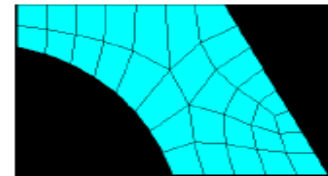

- **Mapped Mesh**

- Restricts element shapes to quadrilaterals for areas and hexahedra (bricks) for volumes.
- Typically has a regular pattern with obvious rows of elements.
- Suitable only for “regular” areas and volumes such as rectangles and bricks.

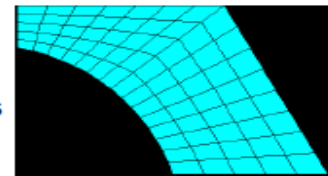

Problem 44. Obtain Stress concentration factor for a Plate with hole under tension, Young's modulus=200GPa, PRXY=0.3

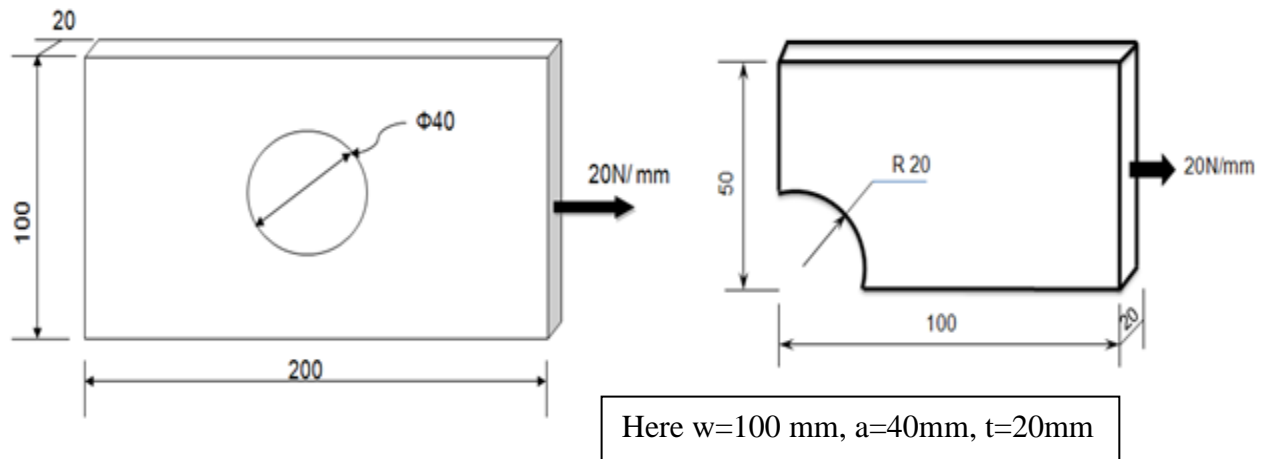

Preprocessing: Defining the Problem:-

Step-1 Preprocessor Menu > Element Type > Add/Edit/Delete > add Solid and Quad 4node 182>Ok> Option>K3-Plane strs w/thk>Ok>Close

Step 2 Preprocessor > Real Constants > Add/Edit/Delete >Add>Ok>thk 20>Ok>Close

Step 3 Preprocessor > Material Props > Material models > Structural > Linear > Elastic > Isotropic > EX20e4, PRXY 0.3>OK> Close

Step 4 Preprocessor > Modeling > Create > Areas > Rectangle > By 2 Corners>X0,Y0 Width 100 and Height 50>OK

Step 5 Preprocessor > Modeling > Create > Areas > Circle > Solid Circle > X0, Y0, R20 >Ok

Step 6 Preprocessor > Modeling > Operate > Booleans > Subtract > Areas

Therefore, select the base area (the rectangle) by clicking on it. Note: The selected area will turn pink once it is selected. The following window may appear because there are 2 areas at the location you clicked.

Ensure that the entire rectangular area is selected (otherwise click 'Next') and then click 'OK'. Click 'OK' on the 'Subtract Areas' window. Now you will be prompted to select the areas to be subtracted, select the circle by clicking on it and then click 'OK'.

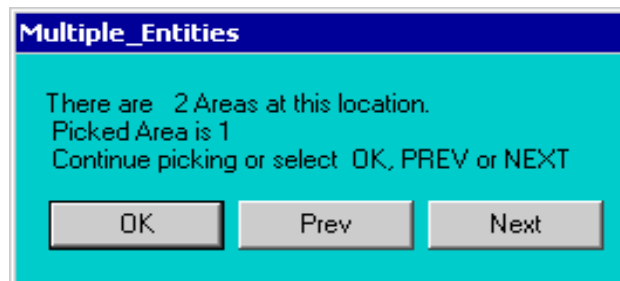

Step 7 **Preprocessor > Meshing > Size Cntrl > Manual Size > Areas > All Areas > 25>OK**

NOTE: Deciding the mesh size/element size is based on the geometry, level of accuracy required and type of element used. Here, element size must be such that mesh includes at least 2 elements at the arc of the hole. Later, this number is increased to improve the accuracy of the solution (convergence study).

Step 8 **Meshing > Mesh > Areas > Free> Pick the rectangle>Ok> li**

Note down the total number of elements and nodes

Solution Phase: Assigning Loads and Solving:-

Step 09 **Define Analysis Type :Solution > Analysis Type > New Analysis>Static> OK**

Step 10 **Apply Constraints :Solution > Define Loads > Apply > Structural > Displacement > Symmetric B.C> on Lines> Select Left side and bottom> OK**

Step 11 **Apply Loads :Solution > Define Loads > Apply > Structural > Pressure > On Lines> Select the Right end of the plate and click on 'Apply'>Load PRES value = (-1) > OK**

Note: a) **Calculate the pressure on the plate end by dividing the distributed load by the thickness of the plate (1 MPa).**

b) **The pressure is uniform along the surface of the plate, therefore the last field is left blank.**

c) **The pressure is acting away from the surface of the plate, and is therefore defined as a negative pressure**

Step 12 **Solving the System : Solution > Solve > Current LS> Ok**

Postprocessing: Viewing the Results

Step 13 **ANSYS : Utility Menu > Plot > Nodes>Utility Menu > PlotCtrls > Numbering**

(The plot should look similar to the one shown below. Make a note of the node closest to the top of the circle (ie. #25))

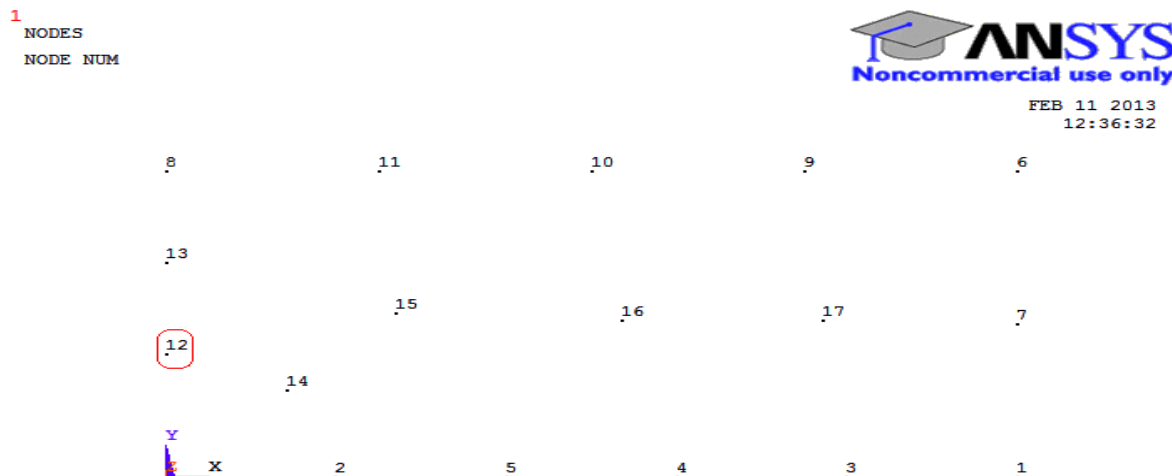

Step 14 Postproc > List Results > Nodal Solution > Stress, von Mises stress>Ok

```

LOAD STEP=      1  SUBSTEP=      1
TIME=      1.0000  LOAD CASE=      0
NODAL RESULTS ARE FOR MATERIAL      1

```

NODE	S1	S2	S3	SINT	SEQU
1	0.96987	0.75055E-01	0.00000	0.96987	0.93461
2	0.49240	0.00000	-0.74372	1.2361	1.0779
3	0.91856	0.37804E-01	0.00000	0.91856	0.90026
4	0.78626	0.00000	-0.12634E-01	0.79889	0.79265
5	0.65121	0.00000	-0.26332	0.91452	0.81540
6	1.0376	0.33397E-01	0.00000	1.0376	1.0213
7	1.0061	0.55093E-01	0.00000	1.0061	0.97973
8	1.1453	0.15475E-01	0.00000	1.1453	1.1376
9	1.0985	0.37623E-01	0.00000	1.0985	1.0802
10	1.2367	0.56760E-01	0.00000	1.2367	1.2093
11	1.1673	0.00000	-0.12180	1.2891	1.2327
12	2.7101	0.35964	0.00000	2.7101	2.5494
13	1.4967	0.44246E-01	0.00000	1.4967	1.4751
14	1.4621	0.00000	-0.98759E-01	1.5608	1.5139
15	1.0761	0.00000	-0.64700E-01	1.1408	1.1098
16	1.0715	0.43484E-01	0.00000	1.0715	1.0505
17	1.0070	0.36442E-01	0.00000	1.0070	0.98923

MINIMUM VALUES					
NODE	2	2	2	4	4
VALUE	0.49240	0.00000	-0.74372	0.79889	0.79265

MAXIMUM VALUES					
NODE	12	12	1	12	12
VALUE	2.7101	0.35964	0.00000	2.7101	2.5494

The Von Mises Stress was found to be **2.5494 MPa** at this point. We will use smaller elements to try to get a more accurate solution.

```

1
DISPLACEMENT
STEP=1
SUB =1
TIME=1
DMX =.588E-03

```



FEB 11 2013
12:45:48

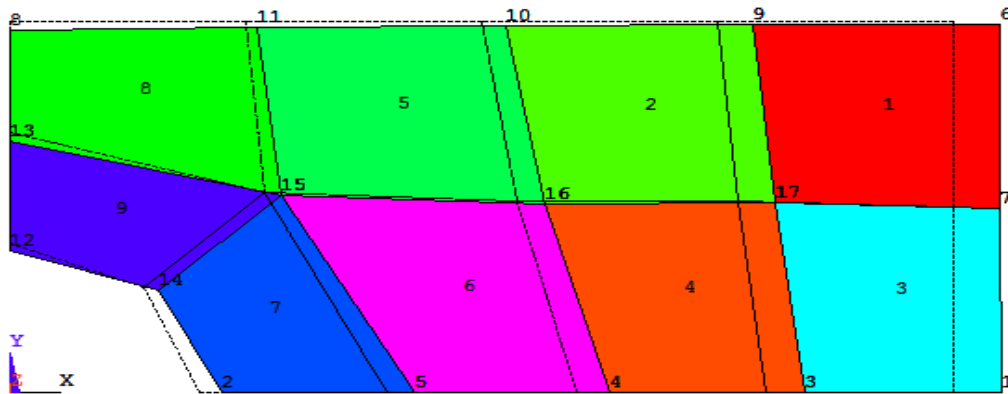

Step 15 Deformation: Genrl Postproc > Plot Results > Deformed Shape > Def + undeformd > Ok

Step 16 Deflection : General Postproc > Plot Results > Contour plot > Nodal Solution > DOF > Solution > Displacement vector sum > OK

1
 NODAL SOLUTION
 STEP=1
 SUB =1
 TIME=1
 USUM (AVG)
 RSYS=0
 DMX =.588E-03
 SMN =.103E-03
 SMX =.588E-03

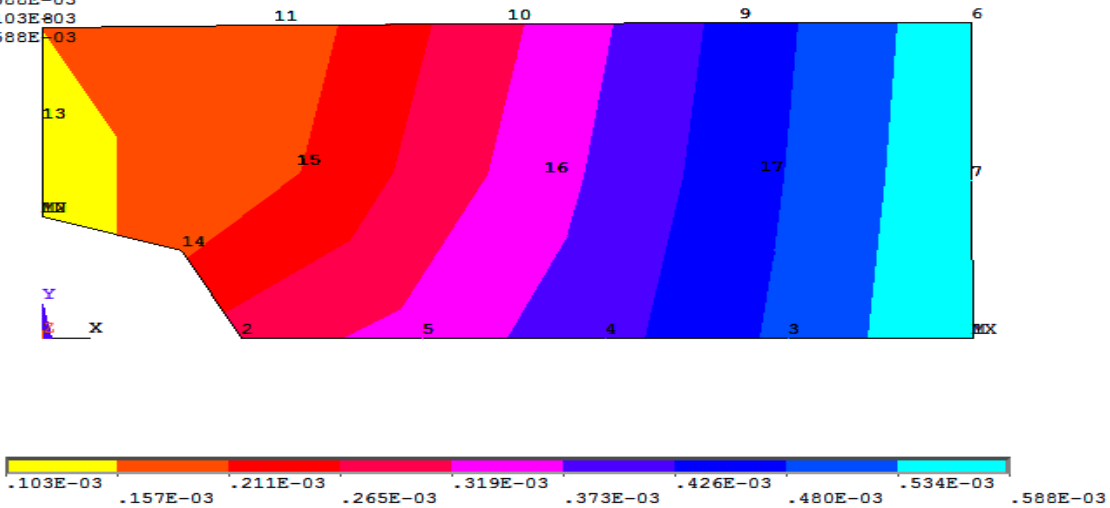

Step17 Stresses: General Postproc > Plot Results > Nodal Solution> Stress> von Misesstress.

Contour Plot of Mises Equivalent

The Mises equivalent stress, stress_bar, is given by the equation :

$$\sigma_{mises_eq} = \left(\sigma_{xx}^2 + \sigma_{yy}^2 + \sigma_{zz}^2 - \sigma_{xx}\sigma_{yy} - \sigma_{xx}\sigma_{zz} - \sigma_{yy}\sigma_{zz} + 3\tau_{xy}^2 + 3\tau_{xz}^2 + 3\tau_{yz}^2 \right)^{0.5}$$

In applying the Von Mises yield criterion, yielding is predicted to occur when $\sigma_{mises_eq} = \sigma_y$ where σ_y is the yield stress measured under uniaxial tension.

Viewing results for the Mises Equivalent Stress can provide insight into the load causing initial yielding and the initial shape of yielding zones.

MAIN MENU -> **General Postproc -> Plot Results-> Contour Plot-nodal solu...**

COUNTOUR NODAL SOLUTION DATA -> **Highlight Stress**

COUNTOUR NODAL SOLUTION DATA -> **Highlight von Mises SEQV**

COUNTOUR NODAL SOLUTION DATA -> **OK**

Note down the maximum stress and location .Predict Stress concentration factor

NODAL SOLUTION
 STEP=1
 SUB =1
 TIME=1
 SEQV (AVG)
 DMX =.588E-03
 SMN =.792653
 SMX =2.5494



FEB 11 2013
 13:01:59

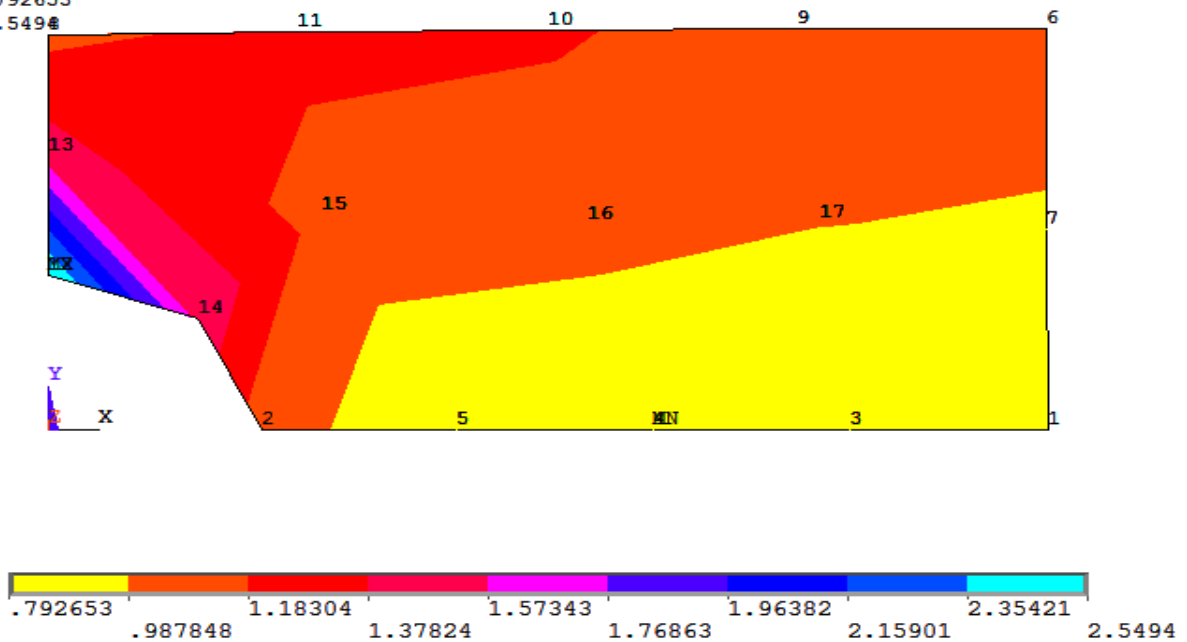

For full expansion of the plate

Utility Menu > PlotCtrls > Style > Symmetry Expansion > periodic /cyclic symmetry > ¼
 Dehydral sym OK

Convergence studies

Step18 Step 7> now decrease the element edge length (**ie 20**) and then >Ok, repeat the steps 8,12...
 Step19 Step 7> now decrease the element edge length (**ie 15**) and then >Ok, repeat the steps 8,12...

Sl.No	Edge Length	No of Nodes	No of Elements	Critical Node number	Von Mises stress at critical point	Stress concentration factor	Maximum deformation at load line(mm)
1	25	17	9	12	2.5494		0.588E-3
2	20	23	14	14	2.53158		0.587E-3
3	15	37	25	19	2.8412		0.606E-3
4	10	61	45	25	3.16908		0.614E-3
5	5	220	190	48	3.36129		0.625E-3
6	1	4677	4532	232	3.71987		0.629E-3

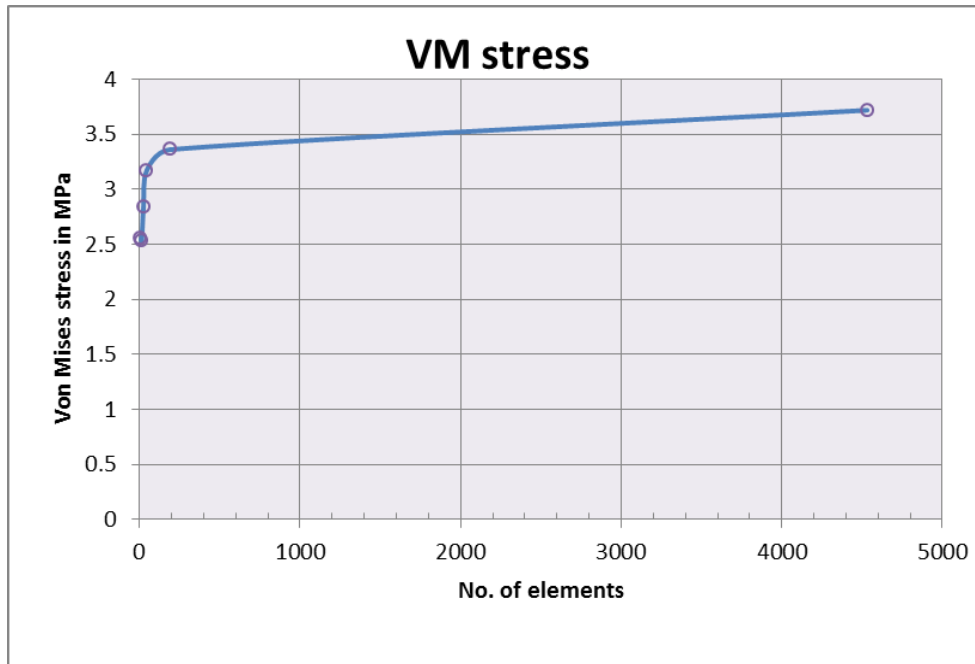

As the number of elements in the mesh increases (i.e. the element edge length decreases), the values converge towards a final solution.

Graph Stresses in Cross Section

- MAIN MENU -> General Postproc -> Path Operations -> Define Path-By Nodes
- DEFINE PATH -> Pick nodes along the left edge of the plate towards the hole. Click OK.
- In the Define Path Name box, type: 1, click OK.
- PATH OPERATIONS -> Map Onto Path, MAP RESULTS ITEMS ONTO PATH -> Highlight Stress, MAP RESULTS ITEMS ONTO PATH -> Highlight X-Direction SX or whichever stress component is relevant.
- MAP RESULTS ITEMS ONTO PATH -> OK
- PATH OPERATIONS -> Plot Path Items -On Graph
- PATH PLOT OF PATH ITEMS -> Highlight SX
- PATH PLOT OF PATH ITEMS -> OK

Calculated net stress concentration factor (SCF):

$$\text{Load, } F = P \times w \times t =$$

$$\sigma_{\text{nominal}} = F / [(w-a)t] =$$

$$K_{\sigma} = \sigma_{\text{max}} / \sigma_{\text{nominal}} =$$

$$\sigma_{\text{max}} = \text{Maximum value of } S_{xx} \text{ on hole boundary at } \theta = 90^{\circ} =$$

Compare this value with that obtained from Data Hand Book.

The von Mises stress at the top of the hole in the plate was found to be approximately 3.8 MPa. This is a mere 2.5% difference between the analytical solution and the solution found using ANSYS.

Note: Refer appendix on the page No 233

Problem 45 : Plate with a Hole

Material : The plate is made of steel with Modulus of elasticity $E = 200 \text{ GPa}$, and Poisson's ratio = 0.25

Unit : SI Units ONLY. It is important to convert pressure to "Pa" and all dimensions to "meters".

Boundary Conditions : We will use symmetry conditions to solve this problem, by considering only the top right quarter of the plate. Therefore, the boundary conditions for the plate are symmetry conditions on the left and bottom parts of the plate.

Loading : Uniform tensile Load with magnitude 1 MPa acting on both left and right sides of the plate (Since we're using symmetry, we will apply pressure to only the right side of the top right quarter of the plate) Because we are performing a linear analysis, a uniform load/area of 1 MPa is appropriate. Stresses, strains and displacements for any other magnitude of loading can be determined by simply re-scaling the results from this model. (eg. To obtain results for a 100MPa load, simply multiply results from this model by 100)

Objectives:

1. To use symmetry conditions to determine magnitudes of maximum stress, minimum stress and their locations on the plate after the load is applied.
2. To model the plate using a default mesh (coarse mesh) and using mesh size control to increase element resolution (fine mesh). You will then determine how element resolution affects the maximum and minimum stresses.

Things to hand in:

1. Contour plot
2. Query of maximum stress
3. Query of minimum stress
4. Plot of stress σ_{xx} and stress σ_{yy} Vs y along $y=0$

Figure and Dimensions:

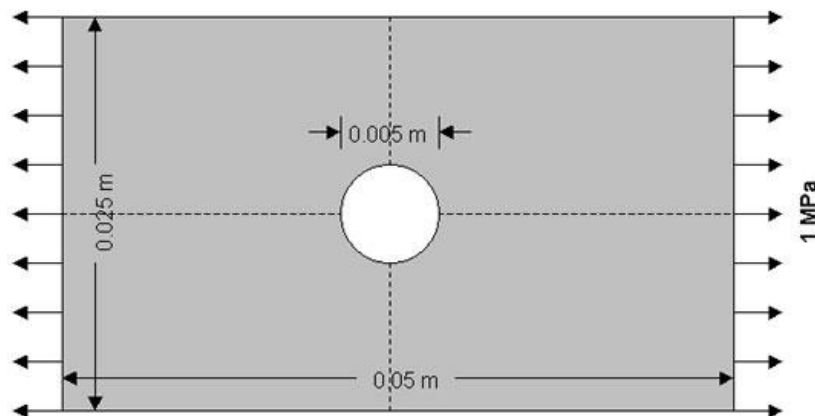

1. Specify Geometry(Quarter domain)

There are several ways to create the model geometry in ANSYS. For this problem, we will use two ways to create the specified object. The first method is to define keypoints then create area rectangles through these keypoints. The second method is to define key points and create lines. After we have the boarder of the object, we will then create an area.

However, in order to see their numbers when creating keypoints, we will need to turn on the keypoint numbers.

ANSYS UTILITY MENU -> **PlotCtrls -> Numbering>on**

check the box next to "Keypoint numbers" to turn it on. Then click **OK** to close the dialog box.

The First Method: Merging Areas

1.1 CREATE KEYPOINTS

In this step, we will create 6 keypoints needed to create the plate areas.

PREPROCESSOR -> **-Modeling – Create -> -Keypoints -> In Active CS...**

The input box "Create Keypoints in Active Coordinate System" should appear on the screen

Then create 6 keypoints at 6 different locations by enter the Keypoint numbers and locations as following:

Keypoint number 1 : (0, 0, 0) -> Click **Apply**

Keypoint number 2 : (0.0125, 0, 0) -> Click **Apply**

Keypoint number 3 : (0.025, 0, 0) -> Click **Apply**

Keypoint number 4 : (0.025, 0.0125, 0) -> Click **Apply**

Keypoint number 5 : (0.0125, 0.0125, 0) -> Click **Apply**

Keypoint number 6 : (0, 0.0125, 0) -> Click **OK**

1.2 CREATE AREA THROUGH KEYPOINTS

The next step, we will create three areas through the keypoints we have created. These three areas are arranged to allow improvements in element resolution which will also improve the accuracy of the analysis.

PREPROCESSOR -> **-Modeling – Create -> -Area –Arbitrary -> Through KPs**

The Create Area Thru KPs window pops up. Pick Keypoints to create areas as followings:

1. Pick Keypoint numbers 1, 5, 6 (Pick in that order). Then click **OK**.

2. Pick Keypoint numbers 1, 5, 2. Click **OK**.

3. Pick Keypoint numbers 2, 3, 4, 5. Click **OK**.

Then you would have the connected area of a rectangle with three different areas in it.

1.3 CREATE CIRCULAR AREA (HOLE)

PREPROCESSOR -> **-Modeling – Create -> -Area –Circle -> Partial Annulus.**The Part Annular Circ Area window should now appear on the screen. Fill in the fields Enter

WP X = 0 Circle center X-Coordinate

WP Y = 0 Circle center Y-Coordinate

Rad-1 =0 Inner radii of the circle or cylinder. A value of zero or blank, or the same value for both Rad-1 and Rad-2, defines a solid circle or cylinder.

Theta-1 = 0 Starting angles of the circle or faces of the cylinder.

Rad-2 =0.0025 Outer radii of the circle or cylinder.

Theta-2 =90 Ending angles of the circle or faces of the cylinder.

Click OK.

1.4 SUBTRACT THE HOLE FROM PLATE

PREPROCESSOR -> **-Modeling – Operate -> -Booleans –Subtract -> Areas.** Pick the base areas from which you want to subtract first (The two triangular areas) First, click on one triangle. **Do not**

click OK yet. Then click on another triangle. Now click **OK**. ANSYS will know that the two area is the base area where the next input area will be subtracted from. Now pick the area to be subtracted (Circular area) Click **OK**. You should now have a plate with a hole as shown :

1.5 MERGE GEOMETRY

To connect all parts together, we will have to merge the keypoints.

PREPROCESSOR -> **Numbering Controls** -> **Merge Items...** Choose Keypoints in the label pick list. Then click OK to merge keypoints and close the dialog box.

Second Method: Creating Area through Key Points

1.1 Create Key Points

PREPROCESSOR-> **-Modeling – Create > -Keypoints** -> **In Active CS...**Then, pick the following 8 points:

Keypoint number 1 : (0, 0, 0) -> Click **Apply**

Keypoint number 2 : (0.0025,0,0) ->Click **Apply**

Keypoint number 3(0.0125, 0, 0) -> Click **Apply**

Keypoint number 4 : (0.025, 0, 0) -> Click **Apply**

Keypoint number 5 : (0.025, 0.0125, 0) -> Click **Apply**

Keypoint number 6 : (0.0125, 0.0125, 0) -> Click **Apply**

Keypoint number 7 : (0, 0.0125, 0) -> Click **Apply**

Keypoint number 8 : (0, 0.0025, 0) -> Click **OK**

Then, you will see the figure which indicates every key points created with its label.

1.2 Create Lines--Straight Lines and Arc.

Here, we have to create straight lines as well as an arc so that we get the same area as from the previous method.

PREPROCESSOR -> **Modeling** -> **Create** -> **Lines** -> **Lines** -> **Straight Lines**

Then, select every line that composes the circumference of the specified object. Now, we will have to create an arc.

PREPROCESSOR -> **Modeling** -> **Create** -> **Lines** -> **Arcs** -> **By End KPs & Radius**

The window will prompt you to pick points which are the end points of your arc. So pick point 2 and 8. Then click **OK**. You will see the same window again. Now, you have to enter any point which is inside the circle. In this case, you just pick point 1. You will then see the window. Enter 0.0025 for radius. 8 and 2 for p1 and p2 and 1 for pc Click **OK**. Then you will get the connected lines needed to define an area. We will move on to creating an area through lines.

1.3 Create Area

PREPROCESSOR -> **Modeling** -> **Create** -> **Areas** > **Arbitrary** -> **By Lines**

Pick all lines by clicking on each of them. Remember that you can unpick the line. But we will not need to do that since we have to select every line. After you selected a line, that line will be highlighted. Click **OK**. Then, you will see the figure on screen

Now, we have defined an area that has the same shape as from the first method. However, when you mesh the area using Free command, the result will be different because ANSYS freely meshed the area which we have defined as the connected piece. If we look at the area created by the first

method, we will see that there were separated areas which will help the software determines the boundary where the meshes start and end. After you mesh the area created by the second method, you should get the following result.

STEP2 Specify Element Type and Material Properties From the drop down menu

PREPROCESSOR -> **Element Type** -> **Add/Edit/Delete...** -> **Add**

Then, you will see the window, LIBRARY OF ELEMENT TYPES, choose structural Solid Quad 4node 182 and type 1 for Element type reference number. Then click **OK**.

Now, we have specified the structural element type.

PLANE182 is now defined and assigned to reference 1.

Note: PLANE182 is used for 2-D modeling of solid structures. The element can be used either as a plane element (plane stress or plane strain) or as an axisymmetric element. The element is defined by four nodes having two degrees of freedom at each node: translations in the nodal x and y directions.

For more details about this or other Element types, see ANSYS help.

The next step is to specify the material properties of the plate. There are 2 ways of doing this.

Method 1

PREPROCESSOR -> **Material Props** -> **Material Models** >**Structural** -> **Linear** -> **Elastic** -> **Isotropic**

After you double click on Isotropic, enter the value for Young Modulus and Poisson Ratio given in this problem. Click **OK**

Method 2

PREPROCESSOR -> **Material Props** -> **Material Library** -> **Import Library**

Click on BIN and **OK**.

Following is the directory where the material property files for different types of materials are.
C:/Program Files/ANSYS Inc/v70/ANSYS/Matlib/fileStd_AISI-304.BIN_MPL

Then, the following window should appear.

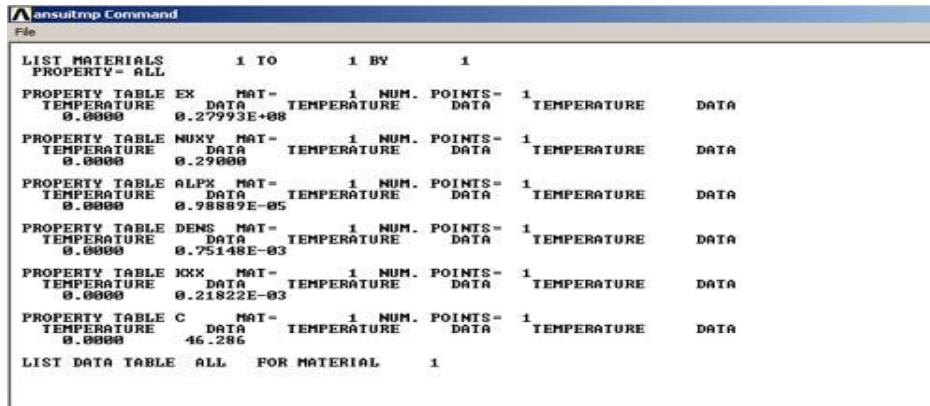

3. Mesh the Object

We will first have ANSYS automatically mesh the model for us (Free Mesh). Then later, we will improve the mesh quality by specifying mesh sizes, which will help improving the accuracy of the results.

MAIN MENU -> **Preprocessor** -> **-Meshing** -> **Mesh** > **Area** -> **Free**

MESH AREAS WINDOW-> Click on **Pick All**. Then click **OK**.

Wait for the program to mesh the part - this may take several seconds. Your meshed plate should appear

4. Apply Boundary Conditions and External Loads

A. Apply Boundary Conditions

In this step we will apply symmetry boundary conditions to left and bottom sides of the plate.

PREPROCESSOR -> **Loads > Apply-> Structural -Displacement -> Symmetry B.C. -On Lines**
ANSYS GRAPHICS WINDOW -> Pick the line on the left edge and 2 lines on the bottom of the plate. Click **OK**.

Then you will see the resulting figure. There will be letter S's appear beside the lines:

4B. Apply External Loads

In this step, we will apply the pressure load to the plate.

PREPROCESSOR -> **Loads -> Define Loads -> Apply -> Structural -> Pressure> On Lines**

ANSYS GRAPHICS WINDOW -> Pick the line on the right edge of the plate. Then click **APPLY** in the APPLY PRES ON LINES Window.

APPLY PRES ON LINES -> Enter -1e6 for the Load PRES value. The value is negative, because it is a tensile load (A negative pressure). Note that value of the pressure entered in this problem is in Pa. (see Figure on screen)

Click **OK**.

The red arrows should now appear on the right side of the beam.

5. Generate a Solution

In the drop down menu, instead of clicking on "Preprocessor", click

SOLUTION > Analysis Type > New Analysis on **Static** Then,SOLUTION -> **Solve -> Current LS**
Click **OK**.

Then the *Note* window will appear. "Solution Done"

Click on **Close**.

6. Postprocessing and Analysis

A. Contour Plot

MAIN MENU -> **General Postproc -> Plot Results -> Contour Plot-Nodal solu...>**
COUNTOUR NODAL SOLUTION DATA ->

Item to be contoured -> Highlight **Stress -> X-direction SX**

Items to be plotted -> **Def + undeformed**

COUNTOUR NODAL SOLUTION DATA -> **OK**.

This displays the results data as contoured lines across the model. You should now have a color representation of the normal stress xx in your plate similar to the Figure below.

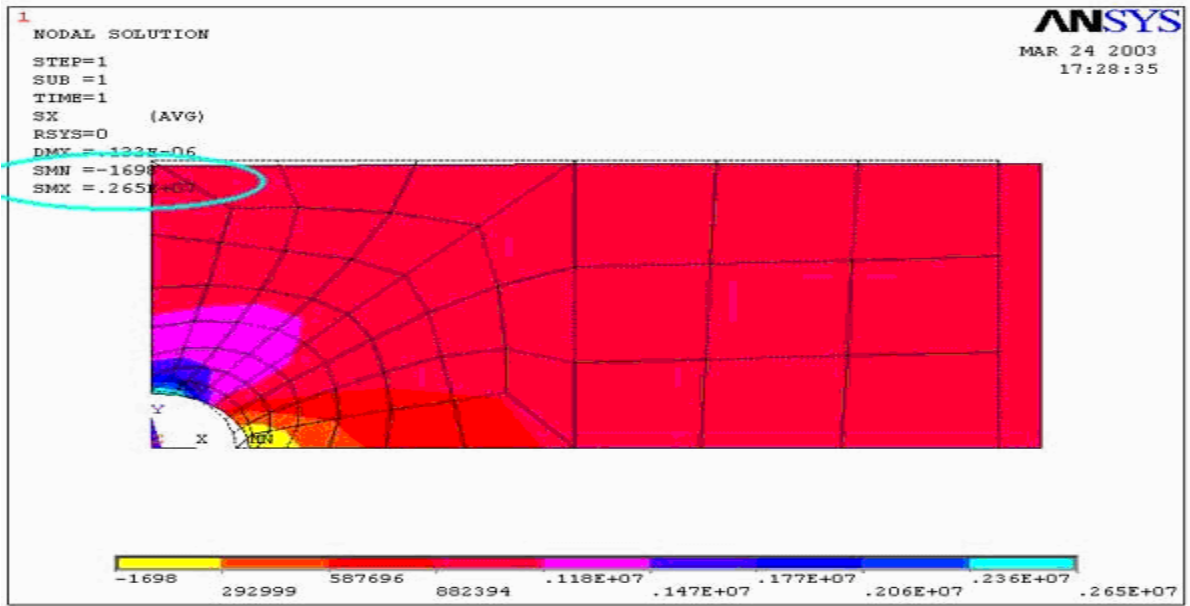

B. Contour Plot of Mises Equivalent

The Mises equivalent stress, σ_{bar} , is given by the equation :

$$\sigma_{\text{mises_eq}} = \left(\sigma_{xx}^2 + \sigma_{yy}^2 + \sigma_{zz}^2 - \sigma_{xx}\sigma_{yy} - \sigma_{xx}\sigma_{zz} - \sigma_{yy}\sigma_{zz} + 3\tau_{xy}^2 + 3\tau_{xz}^2 + 3\tau_{yz}^2 \right)^{0.5}$$

In applying the Von Mises yield criterion, yielding is predicted to occur when $\sigma_{\text{mises_eq}} = \sigma_y$ where σ_y is the yield stress measured under uniaxial tension.

Viewing results for the Mises Equivalent Stress can provide insight into the load causing initial yielding and the initial shape of yielding zones.

MAIN MENU -> **General Postproc** -> **Plot Results**-> **Contour Plot-nodal solu...**

COUNTOUR NODAL SOLUTION DATA -> Highlight **Stress**

COUNTOUR NODAL SOLUTION DATA -> Highlight **von Mises SEQV**

COUNTOUR NODAL SOLUTION DATA -> **OK**

Note down the maximum stress and location .Predict Stress concentration factor

C. Graph Stresses in Cross Section

MAIN MENU -> **General Postproc** -> **Path Operations** -> **Define Path-By Nodes**

DEFINE PATH -> Pick nodes along the left edge of the plate toward the hole.Click **OK**.

In the Define Path Name box, type: **1**, click **OK**. **PATH OPERATIONS** -> **Map Onto Path**

MAP RESULTS ITEMS ONTO PATH -> Highlight **Stress**

MAP RESULTS ITEMS ONTO PATH -> Highlight **X-Direction SX** or whichever stress component is relevant.

MAP RESULTS ITEMS ONTO PATH -> **OK**

PATH OPERATIONS -> **Plot Path Items -On Graph**

PATH PLOT OF PATH ITEMS -> Highlight **SX**

PATH PLOT OF PATH ITEMS -> **OK**

A graph of the stresses along the chosen path will appear as shown in the figure below.

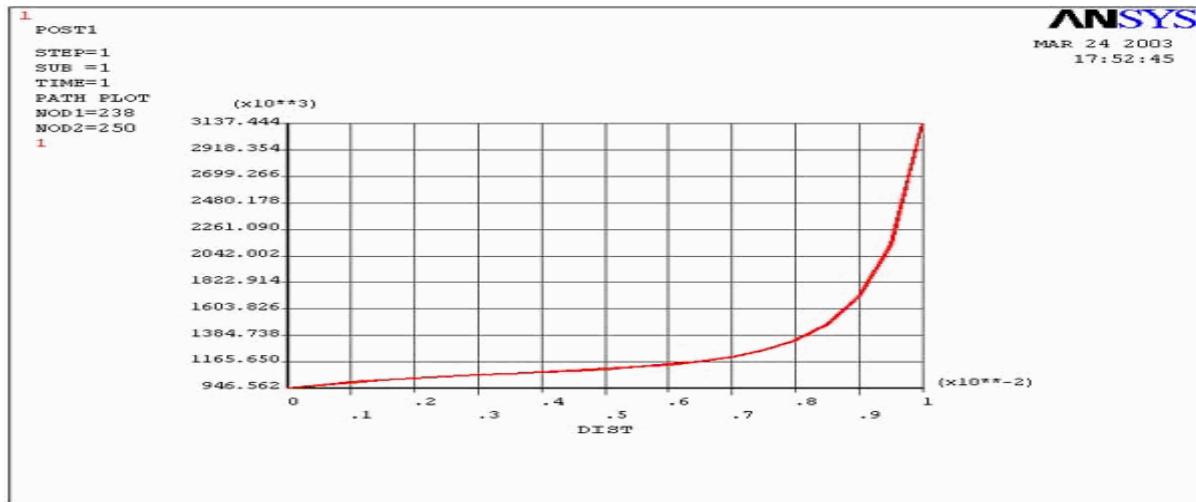

You can also get plots of Sigma yy vs. y by the steps similar to those listed above. Close PLOT RESULTS window.

7. Refine the Mesh

In order to obtain more accurate results, we will refine the previous mesh by assigning mesh sizes to the lines on the plate. Since the area around the hole is of greatest interest, when specifying element sizes, it is better to decrease the line division size as the hole is approached. (More elements near the hole)

However, before refining the mesh, you will have to clear the previous mesh :

PREPROCESSOR -> **-Meshing - Clear> Areas** -> Pick all areas.

You have just cleared your previous mesh. Now we will assign new mesh sizes to the line to create a finer mesh.

PREPROCESSOR -> **-Meshing - Size Cntrls -> Lines -Picked Lines**

ELEMENT SIZE ON PICKED LINES -> There are altogether 10 lines on the plate. In the following 4 steps, we will assign the number of element divisions per line and spacing ratio to each line so that there will be more elements on the area around the hole, and also to arrange the elements in a nice order.

- 1) Pick 2 lines on the edge of the hole, and 2 lines on the opposite sides. Then click APPLY

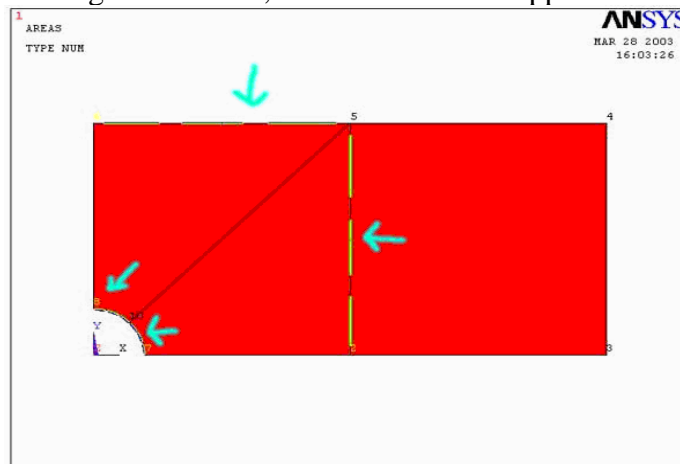

Enter 12 for number of element divisions per line and 1 for Spacing ratio. Then click APPLY. **NDIV** = If positive, NDIV is the number of element divisions per line. If -1, NDIV is **SPACE** = Spacing ratio. If positive, nominal ratio of last division size to first division size (if > 1.0, sizes

increase, if < 1.0 , sizes decrease). If negative, $|\text{SPACE}|$ is nominal ratio of center division(s) size to end divisions size. Ratio defaults to 1.0 (uniform assumed to be zero element divisions per line

2) Pick the three lines that radiate from the hole. Then click **APPLY**.

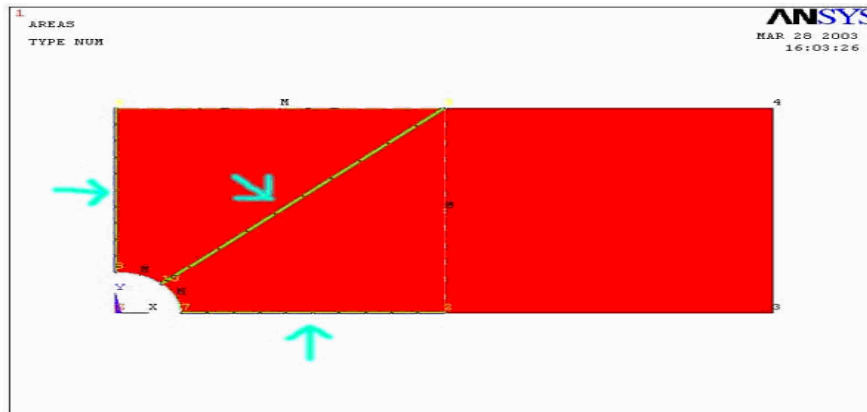

Enter 16 for number of element divisions per line and 0.5 for Spacing ratio. Then click **APPLY**.

(More number of element divisions means more elements near the hole. Also, specifying a Spacing ratio less than 1 means that the element sizes decrease as the hole is approached.)

3) Pick the line on the right most edge of the plate. (See Figure) Then click **APPLY**.

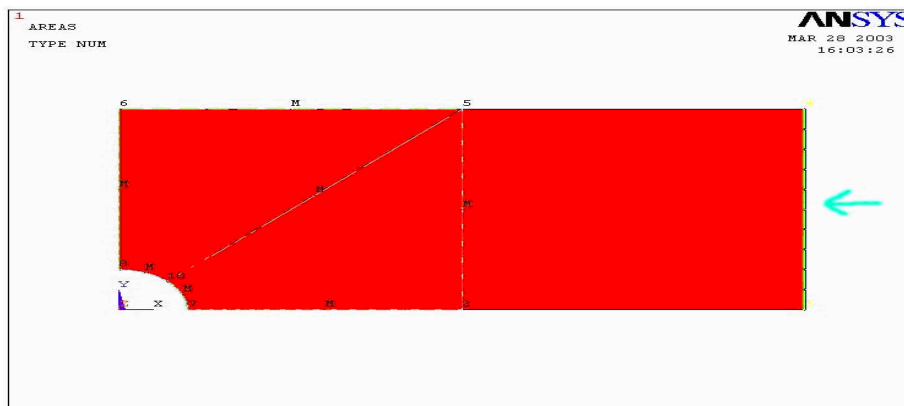

Enter 12 for number of element divisions per line and 1 for Spacing ratio. Then click **APPLY**.

4) Pick the remaining 2 lines. (See Figure) Then click **APPLY**.

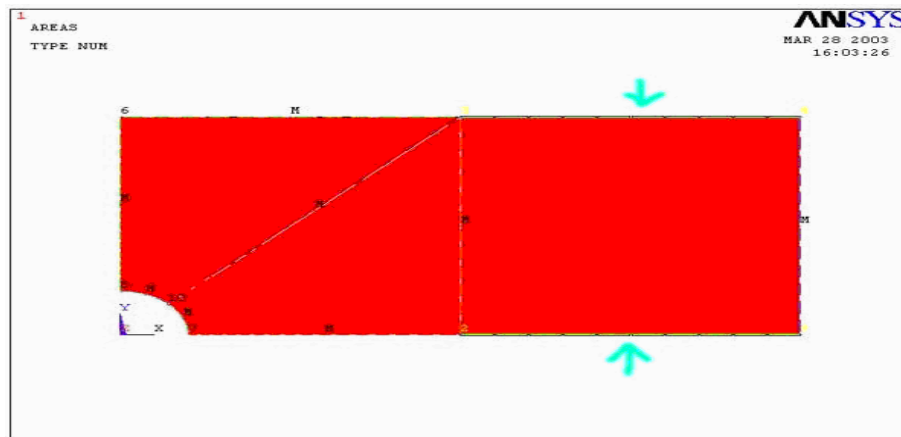

Enter 16 for number of element divisions per line and 0.5 for Spacing ratio. Then click **OK**.

Note that the division sizes on the bottom line decrease as the hole is approached. This is because the number of keypoints on the left of the bottom line is less than of the one on the right, when 0.5 was input for the spacing ratio, ANSYS decreased the division sizes from the left to the right on the line. But since we need the opposite result, the next step will lead you to flip the line division which is what we will do next.

After meshing, you should see the figure below.

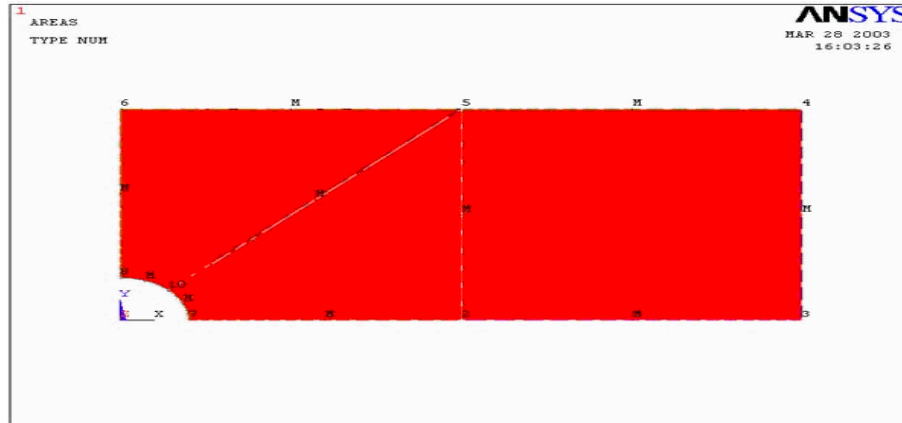

Note that after the lines are meshed, there will be letter **M**'s located beside the lines indicate that they are already meshed. Also notice that when the lines are picked, ANSYS shows the numbers of keypoints of those lines in blue. These numbers are important when you assign the spacing ratio. If the spacing ratio is less than one, element sizes decrease along the line from the former keypoint to latter keypoint.

Now, we will flip the line division using the flip bias command.

SIZE CNTRLS -> **Flip Bias**

FLIP LINE BIAS -> Pick the bottom line that needs to be flipped.

Click **OK**. Now the plate is ready to be meshed.

PREPROCESSOR -> **-Meshing -Mesh -> Areas -Mapped 3 or 4 sided**

MESH AREAS -> Pick all areas.

MESH AREAS -> **OK**.

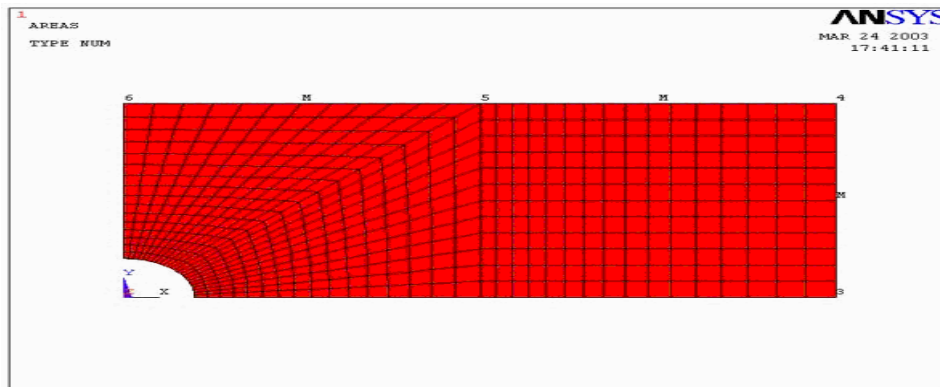

Generate a solution, then obtain results as in steps 6a - 6e. Compare results with the ones previously obtained from auto-meshed model. Observe how the results changed with mesh resolution.

<-----Contour Plot of Mises Equivalent

<-----Stress xx V.S. y

<-----Stress yy V.S. y

8. Interpreting Your Results

In this step, we will compare the results of the coarse-meshed plate with those of the fine-meshed plate. The results we are going to consider are:

1. Contour Plots of the Stress xx: Maximum and Minimum Stresses xx
2. Contour Plots of the Mises Equivalent Stress : Relate to Von Mises Yield Criterion
3. Stress xx across the cross section (At x=0)
4. Stress yy across the cross section (At x=0)

Maximum and Minimum Stresses xx :

Result of free mesh (coarse) model :<--- Contour Plot of Stress xx

Maximum Stress xx = 0.265E+7 Pa

Minimum Stress xx = -1698

Result of mapped mesh (refined) model : <--- Contour Plot of Stress xx

Maximum Stress xx = 0.314E+7 Pa

Minimum Stress xx = -25771 Pa

Interpretation of the Results:

1. As shown in both figures above, the top point of the hole (The red area) has positive (tensile) stress, while the point on the right edge of the hole has a compressive stress. This is consistent with what is seen in the closed-form solution for a hole in an infinitely large plate under far-field uniform tension. Note that the dash lines represent undeformed shape of the plate.
2. With higher mesh resolution, it is clear that the stress contour lines are smoother.
3. According to The Stress-concentration factor chart of a finite-width plate with a circular hole (Peterson, 1974), $K = 3.14$, where $K = \text{Stress_max}/P$, where $P = \text{Pressure Load}$ and $a/w = 0.2$. The stress-concentration factors K for both cases obtained using maximum stresses obtained from the contour plots are:

$$K_{\text{free}} = 2.65$$

$$K_{\text{map}} = 3.14$$

From these results, it is clear that the higher mesh resolution gives more accurate results.[UP](#)

Von Mises Equivalent Stress :

Result<--- Contour plot of Mises Equivalent Stress

Maximum SEQV = 0.270E+7 Pa of free mesh (coarse) model :

Result of mapped mesh (refined) model : <--- Mises Equivalent Stress

Maximum SEQV = 0.305E+7 Pa

Interpretation of the Results:

1. As with the stress xx, with higher mesh resolution, the lines separating the Von Mises Stress contours are smoother.
2. In each case, the maximum Von Mises Stress occurs at the edge of the hole as expected. At this point, the stress state is uniaxial, so that the Von Mises Stress equals the stress xx. The differences between the Von Mises Stress and the stress xx in the FEA models is due to the models not precisely picking up the traction-free boundary condition at the hole boundary.
3. In applying the Von Mises Yield criterion, yielding is predicted to occur when Mises Equivalent Stress(maximum) = Yield Stress.

$$\text{Yield Stress}_{\text{free}} = 0.270\text{E}+7 \text{ Pa}$$

$$\text{Yield Stress}_{\text{map}} = 0.305\text{E}+7 \text{ Pa}$$

This for a yield stress of 350 MPa, initial yielding will occur when the applied load equals :

$$10^6 \cdot \frac{350 \cdot 10^6}{0.305 \cdot 10^7} = 1.148 \times 10^8$$

$$\frac{\text{Current Applied Load} \times \text{Yield Stress}}{\text{Current Maximum Von Mises Stress}} = 115 \text{ MPa}$$

4. Note also that the initial yielded zone near the top edge of the hole will look like the Von Mises contour lines. There will be some difference, though, because an actual yielded plate will experience some load redistribution due to yielding. The only way to precisely track the boundary between yielded and unyielded material as the load is increased is to perform a more complicated elastic-plastic analysis.

Stress xx across the cross section :

Interpretation of the Results:

1. With higher mesh resolution, the graphed line is smoother and the maximum value is larger.
2. The average stress xx across the cross section can be calculated by using the following formula :

$$\sigma_{\text{ave}} = \frac{P \cdot \frac{w}{2}}{\frac{(w-a)}{2}}$$

Where
 P = Pressure Load
 w = Width of the plate
 a = Diameter of the hole

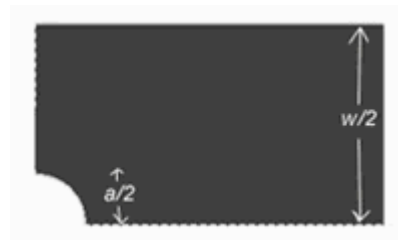

With values P=1000000 Pa, w = 0.025, a = 0.005, The average Stress is 1,250,000 Pa. This is also the "average" stress in the plots of the stress xx VS y. The effect of the hole is to elevate the stress to a value above the average for locations near the hole, and to reduce the stress to a value below the average for locations away from the hole. Another way of thinking of this is that the area under the stress xx VS y curve is the total load carried by the unit-thickness plate, i.e.

$$\text{Load} := \int \sigma_{xx} dA$$

For a given applied load, introducing a stress concentration simply changes the distribution of the stress xx, but the area under the curve is the same.

Interpretation of the Results:

1. As for the stress xx, with higher mesh resolution, the graphed lines of the stress yy is smoother.
2. From your knowledge of boundary conditions, you know that the stress yy is zero at the edge of the plate and at the edge of the hole. The FEA solution will capture this boundary condition only in the limit of a highly refined mesh. You can see that the refined mesh is doing a better job at capturing the traction-free boundary condition at both edges. Although the refined model is still showing significant stress yy at the hole boundary, this discrepancy does not seem to be significantly affecting values of the stress xx or the Von Mises Equivalent Stress.

9. Exit the Program

Exercise: Do the convergence study on Von Mises stress, for the previous problem by increasing the number of elements (plot VM stress vs no. of elements):

Problem46: Consider the square plate of uniform thickness with a circular hole with dimensions shown in the figure below. The thickness of the plate is 1 mm. The Young's modulus $E = 10^7$ MPa and the Poisson ratio is 0.3. A uniform pressure $p = 1$ MPa acts on the boundary of the hole. Assume that plane stress conditions prevail. The stress and displacement fields are to be determined using ANSYS.

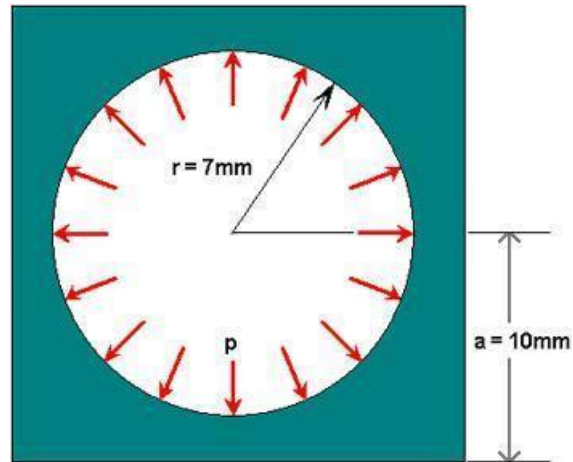

Step 2 Main Menu > Preferences > Structural > OK

Step 3 Utility Menu > Parameters > Scalar Parameters

Enter the parameter value for $a = 10 \times 10^{-3}$ Click *Accept*. Similarly, enter the other parameter

values and click *Accept* after each. $r = 7 \times 10^{-3}$, $p = 1 \times 10^6$, $E = 1 \times 10^{13}$, $\nu = 0.3$ > Close

Step 4 Main Menu > Preprocessor > Element Type > Add/Edit/Delete > Add > Solid Quad 4 node 182 > Ok > close

Step 5 Main Menu > Preprocessor > Real Constants > Add/Edit/Delete > Add

You should get a note saying "Please check and change keyopt setting for element PLANE42 before proceeding." Close the yellow warning window and the *Real Constants* menu.

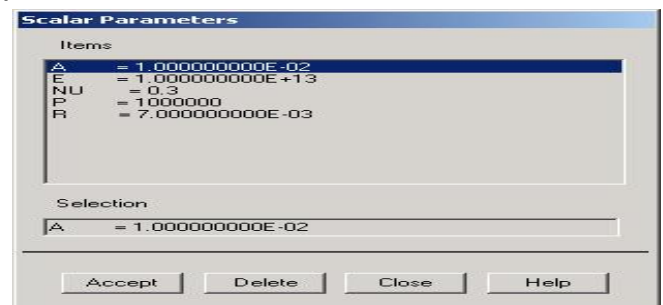

Toolbar > SAVE_DB

Step 6 Main Menu > Preprocessor > Material Props > Material Models > *Structural* > *Linear* > *Elastic* > *Isotropic* > EX=E, PRXY= ν > OK > close

Toolbar > SAVE_DB

Step 7 Main Menu > Preprocessor > Modeling > Create > Areas > Rectangle > By Dimensions > "0" for X_1 , and "a" for X_2 , "0" for Y_1 , and "a" for Y_2 . > Ok

Step8 Main Menu > Preprocessor > Modeling > Create > Areas > Circle > Partial Annulus>

X=0, Y=0, Rad1=0, $\theta_1=0$, Rad2=r, $\theta_2 =90$ > Ok

Step 8 Main Menu > Preprocessor > Modeling > Operate > Booleans > Subtract > Areas> pick base areas from which to subtract > ok> pick areas to be subtracted

Toolbar > SAVE_DB

Mesh geometry:

Step 9 Main Menu > Preprocessor > Mesh Attributes> default Attributes> ok>mesh tool>check smart size-5>mesh> Toolbar > SAVE_DB

Step 10 Main Menu > Preprocessor > Loads > Define Loads > Apply > Structural > Displacement > Symmetry B.C. > On Lines> Left end and bottom end>ok

Step 11 Main Menu > Preprocessor > Loads > Define Loads > Apply > Structural > Pressure > On Lines> Arc> Enter p for Value and click OK ok>Toolbar > SAVE_DB

Step 12 Main Menu > Solution > Solve > Current LS>ok

Step 13 Main Menu > General Postproc > Plot Results > Deformed Shape>OK

Step 14 Main Menu > General Postproc > Plot results > Contour Plot > Nodal Solution>stress> von mises Stress> ok

Step 15 Main Menu > General Postproc > Plot results > Contour Plot > Element Solu> stress> von mises Stress> ok

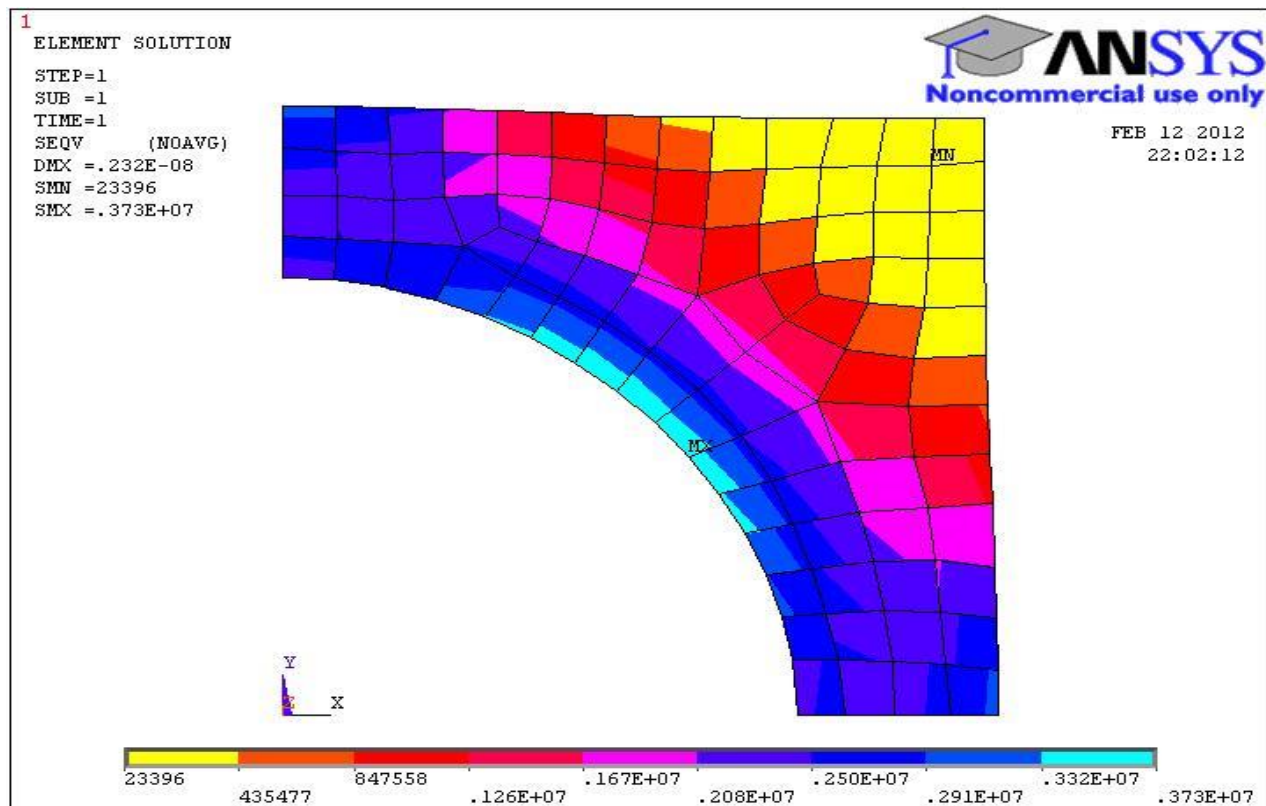

Step16 Main Menu > General Postproc > List Results > Reaction Solution>All Struc forc F>ok

```

PRRSOL Command
File
PRINT F REACTION SOLUTIONS PER NODE
***** POST1 TOTAL REACTION SOLUTION LISTING *****
LOAD STEP= 1 SUBSTEP= 1
TIME= 1.0000 LOAD CASE= 0
THE FOLLOWING X,Y,Z SOLUTIONS ARE IN THE GLOBAL COORDINATE SYSTEM
NODE FX FY
1 -1043.5 -1040.0
3 -697.78 -693.60
4 -2007.8
44 -1764.8
45 -1493.9
46 -2004.4
47 -1764.9
48 -1489.3
TOTAL UALUES
VALUE -7000.0 -7000.0
    
```

Refine Mesh

Let's repeat the calculations on a mesh with overall element size level under *SmartSize* set to 4 instead of 5 and Compare the results on the two meshes. Delete the current mesh:

Step17: Main Menu > Preprocessor > Mesh *Attributes*> *default Attributes*> *ok*>*mesh tool*>*check smart size-4*>*mesh*> Toolbar > SAVE_DB
 Step19; follow step10 to step 17 for better result

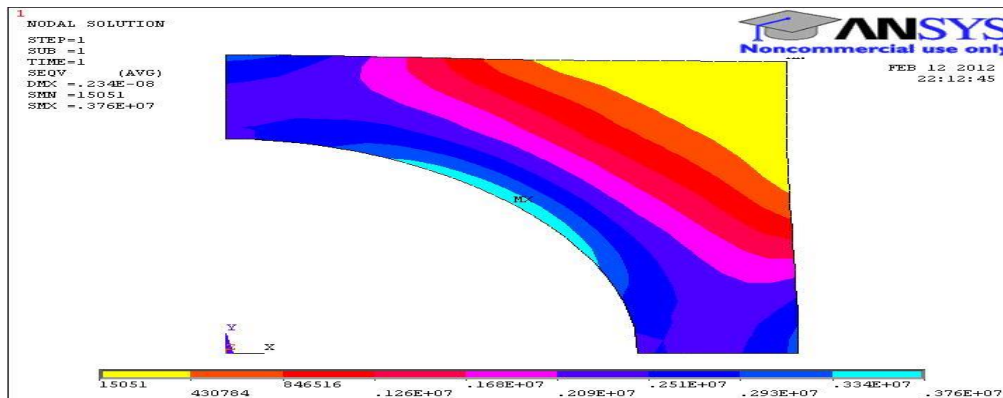

The two results Compare well with the finer mesh contours being smoother as expected. Compare the maximum stress and displacement values:

	Coarser Mesh-5	Finer Mesh-4
DMX	0.232e-8m	0.234e-8m
SMX	3.73MPa	3.76MPa

The maximum displacement value and Maximum Von Mises Stress Value changes by less than 1%. This indicates that the meshes used provide adequate resolution.

Problem 47: Find the stress concentration for the steel plate subjected to different load cases as mentioned in the table.

Assume the dimensions of the plate to be 100mm square and hole dia 25 mm

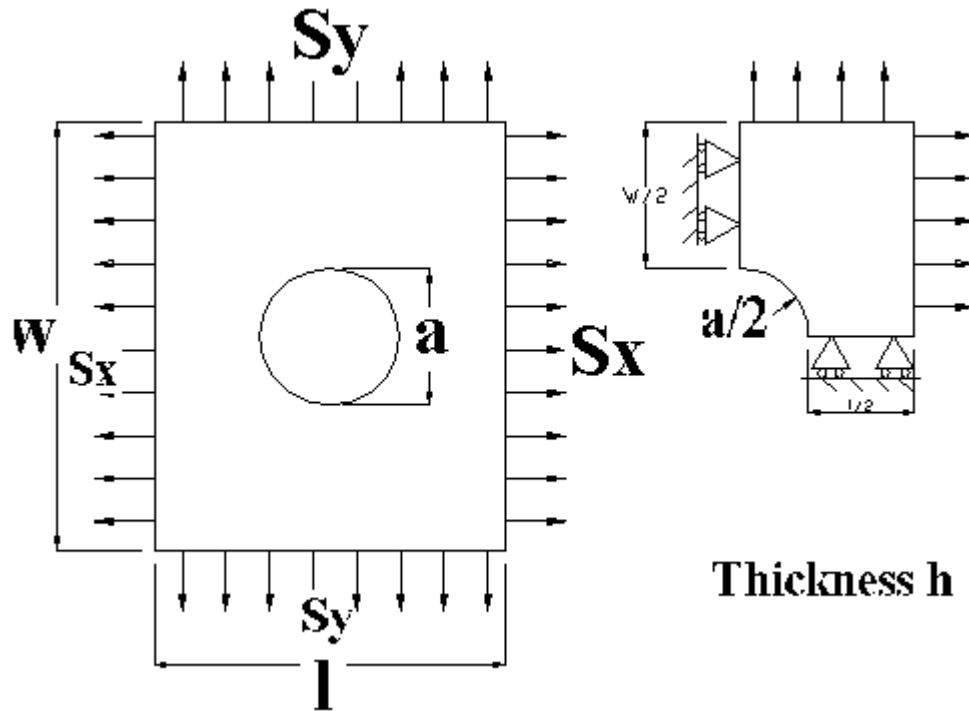

Sl. No	Load case	W (mm)	a (mm)	a/W	h	Load F in (N)	Max. Stress	Nominal stress $\sigma_{nom} = F / ((W-a) * h)$ N/mm ²	Stress Concentration Factor
1	$S_x = 1000 \text{ N/mm}^2$ $S_y = 0$								
2	$S_x = 0$ $S_y = 800 \text{ N/mm}^2$								
3	$S_x = 1000 \text{ N/mm}^2$ $S_y = 800 \text{ N/mm}^2$								

* Compare the stress concentration factor with the values mentioned in the design data hand book

Problem 48: Find the stress concentration for the plate subjected to pure shear. Equivalent loading is shown. $S_x = -S_y = S = 100\text{MPa}$

Assume the dimensions of the plate to be 100mm square and hole dia 25 mm

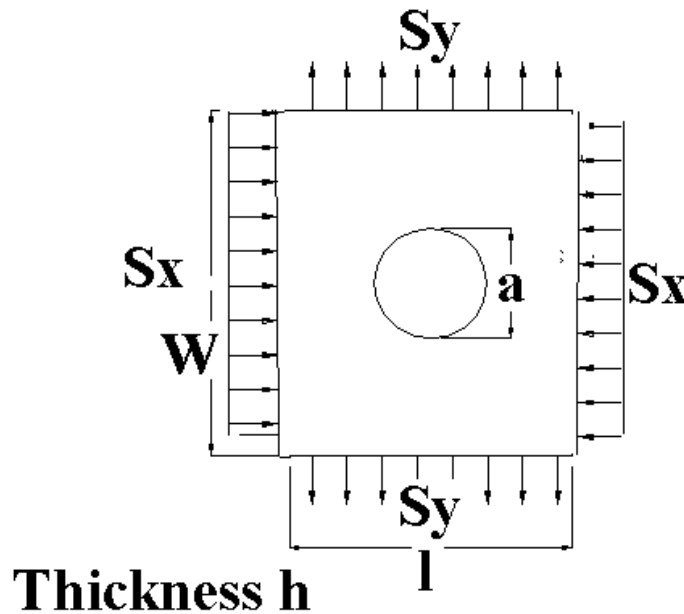

Sl. No	W (mm)	a (mm)	a/W	h	Load F in (N)	Max. Stress	Nominal stress $\sigma_{nom} = F/(W-a)*h$ N/mm ²	Stress Concentration Factor
1								

* Compare the stress concentration factor with the values mentioned in the design data hand book

Problem 49: Determine the location and magnitude of Maximum Von-Mises stress in a plate as shown in figure. Also find the stress concentration factor (Use **mapped mesh with element size of 2mm or less**)

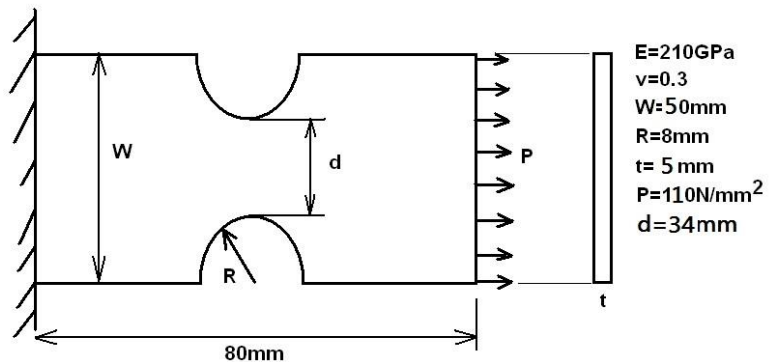

FE Model

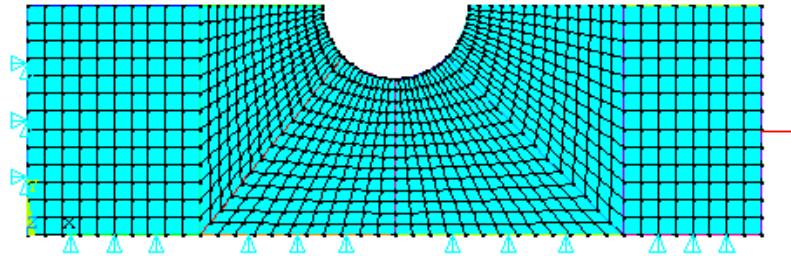

VM Stress Plot

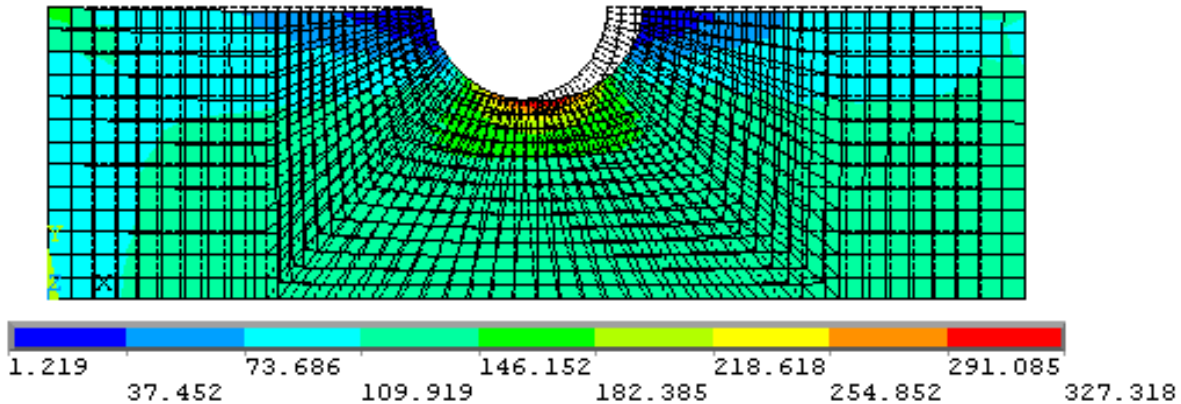

Max Von Mises stress from ANSYS, $\sigma_{\max}=327.318\text{MPa}$

$$\text{Nominal stress, } \sigma_{\text{nom}} = \frac{F}{A_{\text{min}}} = \frac{110 \times (50 \times 5)}{(50 - 16) \times 5} = 161.765\text{MPa}$$

$$K_{\sigma} = \frac{\sigma_{\max}}{\sigma_{\text{nom}}} = \frac{327.318}{161.765} = 2.023$$

Problem 50:

Solve the following problem using symmetric model with mapped mesh approach. Determine the maximum deformation and stress.

E=210GPa, v=0.3, Plate thicknes=0.05m

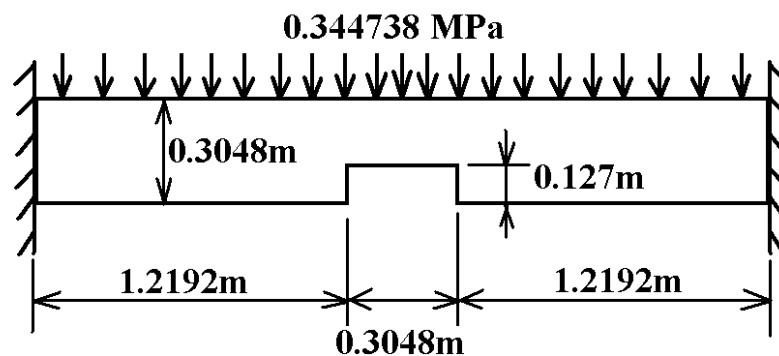

Solution:

Chapter 09: Introduction to Axisymmetric Analysis

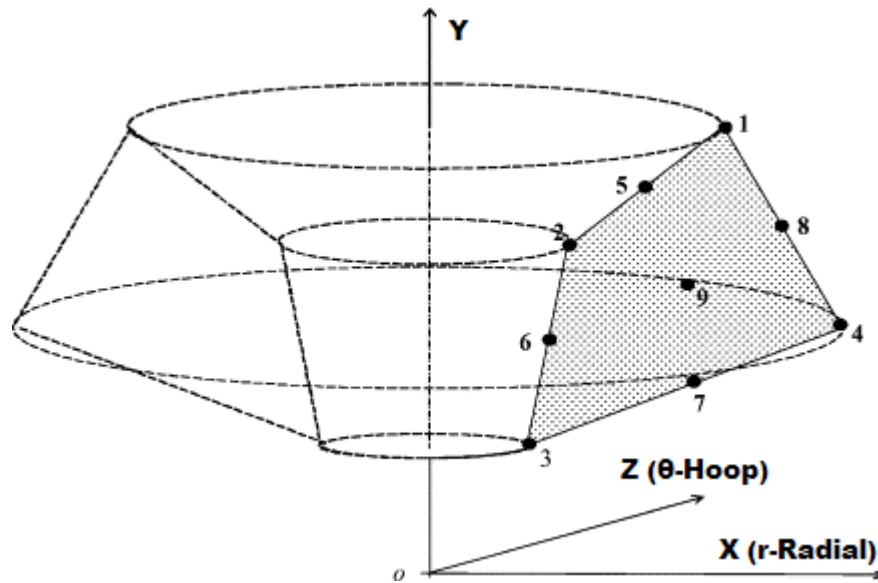

Problems involving three-dimensional axisymmetric solids or solids of revolution, subjected to axisymmetric loading, reduce to simple two-dimensional problems. Because of total symmetry about the Y axis, as seen in the fig. all deformations and stresses are independent of the rotational angle θ . Thus the problem needs to be looked at as a two-dimensional problem in XY, define on the revolving area. Examples: Pressurized cylinders, cooling towers and revolving bodies like Disk type Flywheel, Shafts.

Problem 51: A pipe of 100mm external dia. And 20mm thickness carries water at a pressure of 20MPa. Determine the maximum and minimum intensities of hoop stresses in the section of pipe. Also plot the variation of hoop and radial stresses across the thickness of pipe.

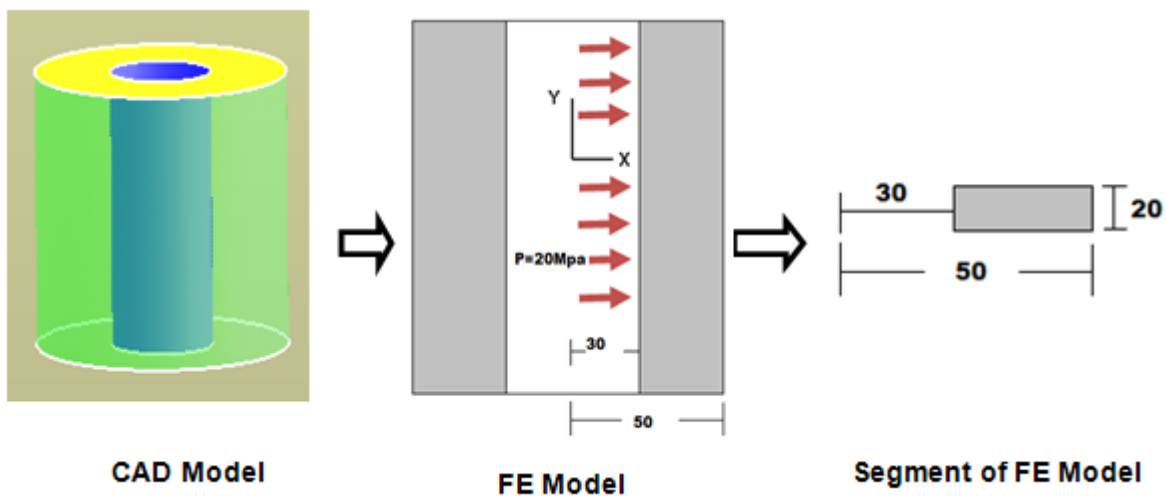

1. Preprocessor > Element Type > Add/Edit/Delete > Add > Solid > select Quad 4 Node 182 > OK > Options (Element Behavior)> Axisymmetric > OK > Close

2. Preprocessor > Material Props > Material Models > Structural > Linear > Elastic > Isotropic >Enter Ex = 2.e5 and PRXY = 0.3 > OK > Close.

Note: In ANSYS the Y axis is always the axis of symmetry for axisymmetric problems.

3. Preprocessor -> Create -> Areas -> Rectangle ->By 2 Corners

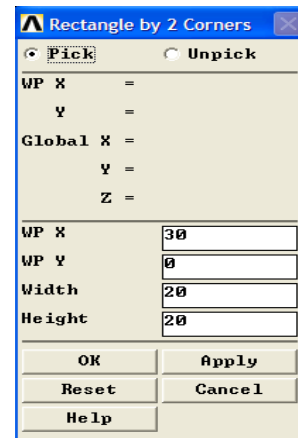

4. Preprocessor -> Meshing -> mesh tool -> (Click on smart size and reduce to fine mesh-3) >pick the rectangular area>ok

5. Solution -> Loads ->Apply ->Displacement -> On Lines (Pick the bottom line of the rectangle) $u_y = 0$ along this line. This simply prevents rigid body motion in the Y direction. No other displacement boundary conditions are required. The radial movement is prevented by the 'hoop' tension in the cylinder.

6. Solutions -> Loads ->Apply ->Pressure -> On Lines (Pick the left hand line of the rectangle). Enter a pressure of 20

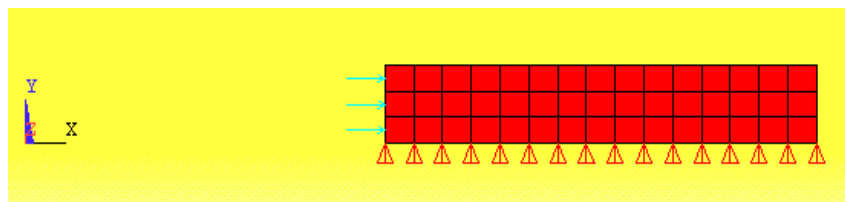

7. Solution -> Solve -> Current LS ->OK

8. General Post Processor -> Plot Results -> Deformed Shape . . . ->Def +undeformed -> OK

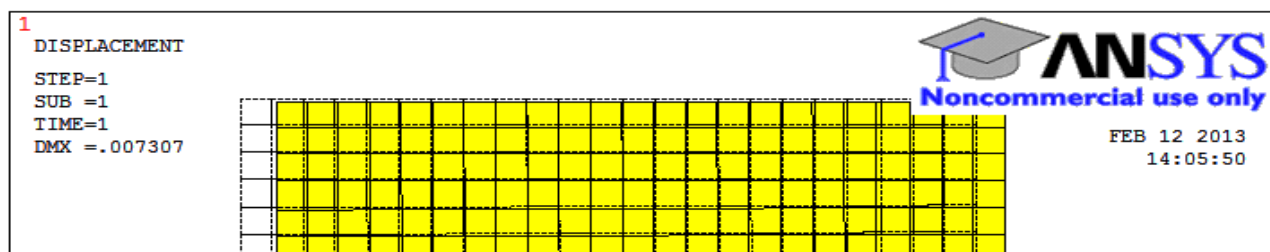

9. General Postprocessor -> Plot Results ->Contour plot> Element Solu >Stress>X component of stress>ok (Pick Sx, Sz and examine each).

Sx (Radial stresses).....

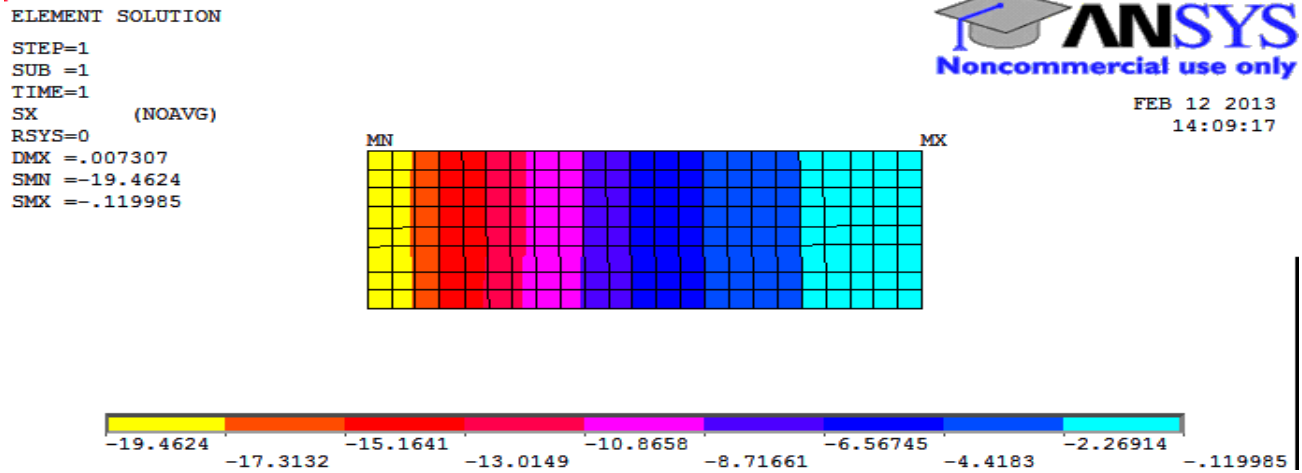

The SX stress is the radial stress that is equal to the pressure (20MPa) on the interior of the cylinder and is zero on the exterior. We will need to examine the computed values more closely evaluate this further.

10. General Postprocessor -> Plot Results ->Contour plot> Element Solu >Stress>Z component of stress>ok (Pick Sx, Sz and examine each).

Sz (hoop stresses).....

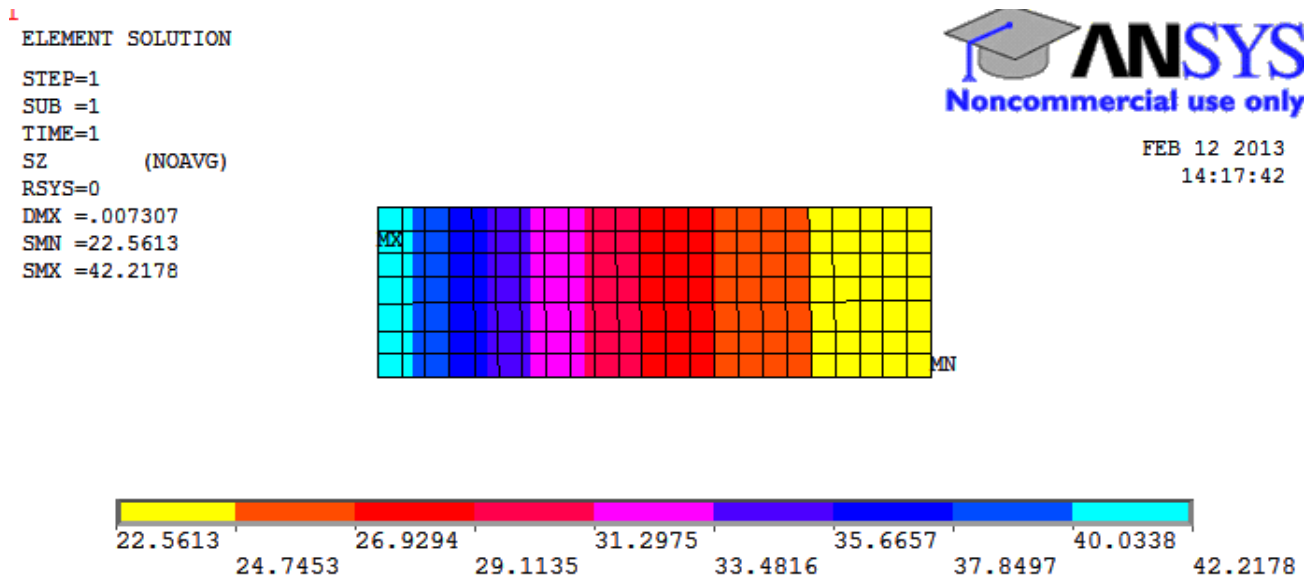

SZ is the 'hoop' stress perpendicular to the plane of this rectangle and varies from **22.5613 to 42.2178 MPa** in the legend above.

11.Graph Stresses in Cross Section:

MAIN MENU: General Postproc > Path Operations > Define Path-By Nodes

DEFINE PATH: Pick nodes along the Radius (Horizontal) from inner radius to outer radius. Click OK.

In the Define Path Name box, type: Dist, click OK.

PATH OPERATIONS: Map Onto Path> Highlight Stress

MAP ONTO PATH: User Label Item >Hoop> StressHighlight Z-Direction SZ(Hoop) >OK

MAP ONTO PATH: User Label Item >Radial> StressHighlight X-Direction SX(Radial) >OK

PATH OPERATIONS: Plot Path Items -On Graph > Highlight SZ & SX > OK

A graph of the stresses along the chosen path will appear as shown in the figure below.

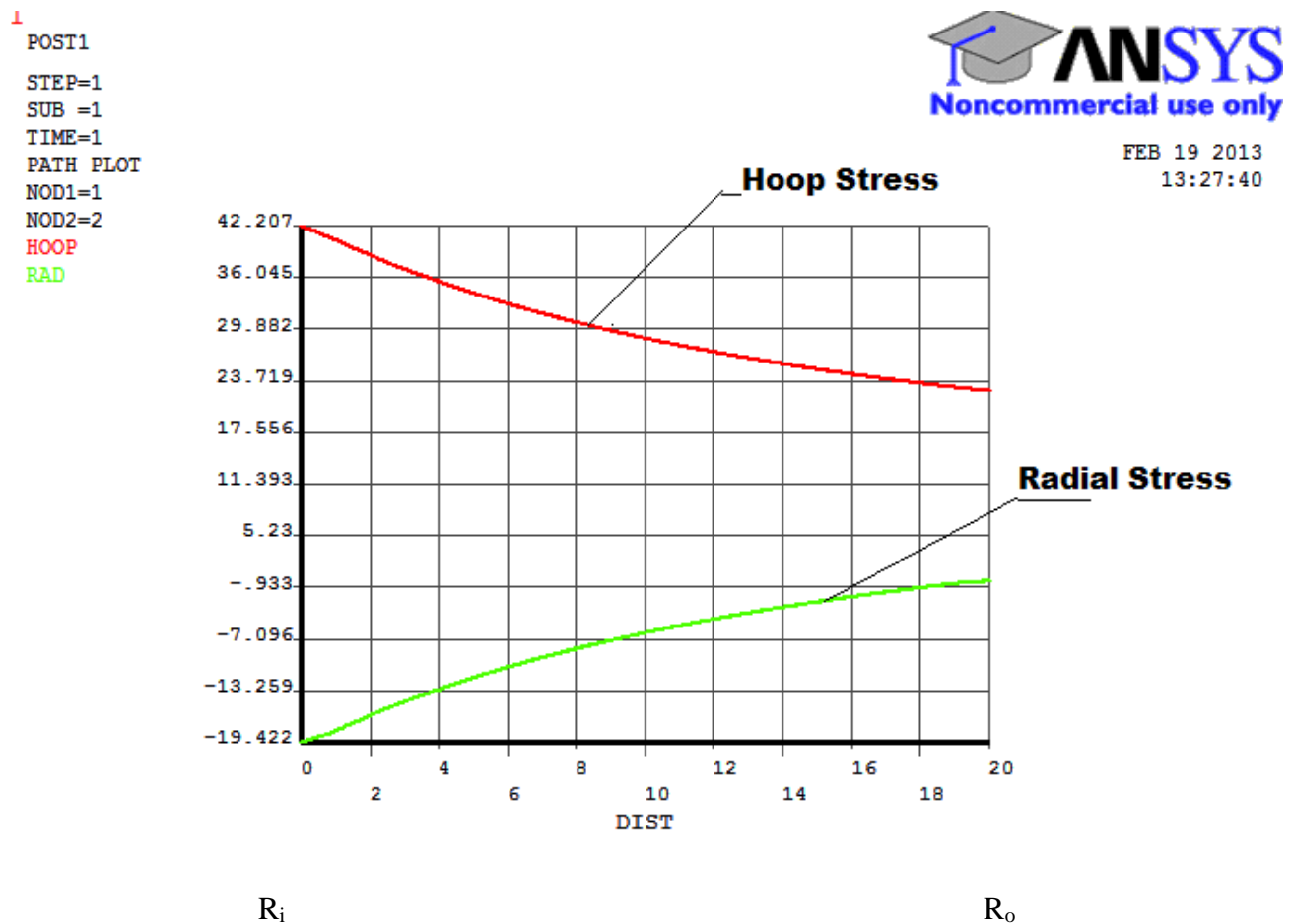

Variation of Hoop and Radial Stress across thickness

We can calculate SX and SZ from solid mechanics formulas for thick walled cylinders. These equations are given by

$$\sigma_{\theta} = \frac{p_i r_i^2 - p_o r_o^2 - r_i^2 r_o^2 (p_o - p_i) / r^2}{r_o^2 - r_i^2}$$

$$\sigma_r = \frac{p_i r_i^2 - p_o r_o^2 + r_i^2 r_o^2 (p_o - p_i) / r^2}{r_o^2 - r_i^2}$$

$$\sigma_i = \frac{p_i r_i^2}{r_o^2 - r_i^2}$$

for thin walled sections

$$\sigma_{t,w} = \frac{p_i d_i}{2t}; \quad \sigma_{t,max} = \frac{p_i (d_i + t)}{2t}; \quad \sigma_i = \frac{p_i d_i}{4t}$$

At the inside of the cylinder SX(Radial Stresses) = 20MPa and SZ(Hoop Stresses) = 42.2178

At the outside of the cylinder SX = 0 MPa and SZ = 22.5613

Thus the ANSYS calculated results agree pretty well with the theory. Here, **radial stress is negative and Hoop stress is positive.**

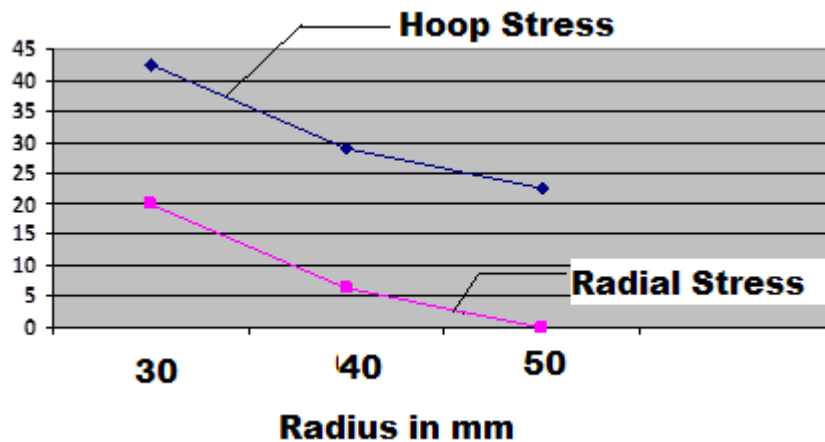

Variation of hoop and Radial stress in MPa across radius

Problem 52: A thick cylinder has inner and outer dia as 120mm and 180mm respectively, it is subjected to an external pressure of 9MPa. Determine the maximum and minimum intensities of Hoop stresses in the section of pipe also plot the variation of hoop and radial stresses across the thickness of pipe.

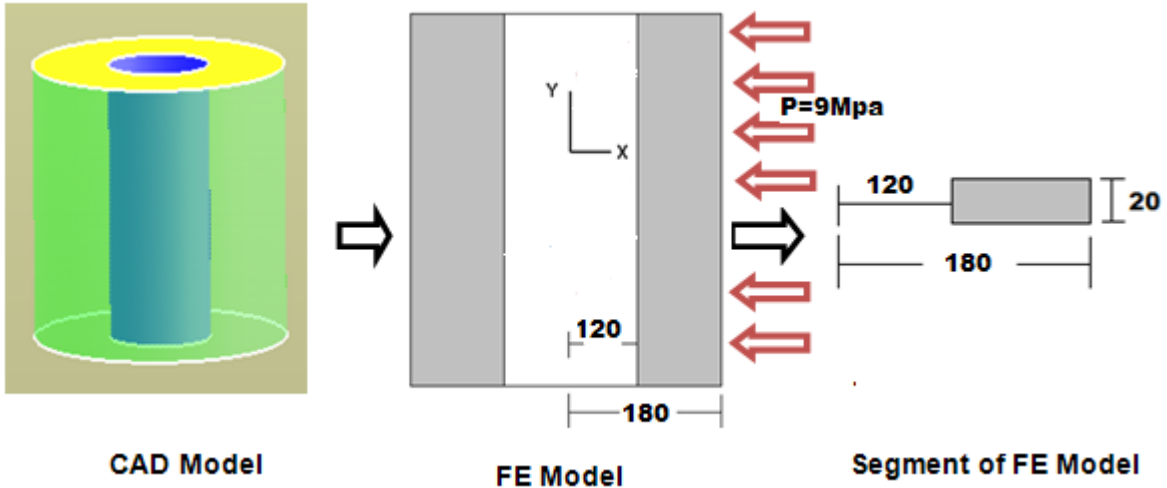

Problem 53: A disk of uniform thickness and of dia 600mm rotates at 1800rpm, if a hole of dia 100mm is made at the center of the disk. Find the Hoop stresses in the section of pipe also plot the variation of hoop and radial stresses across the thickness of pipe for Case (a) and Case (b).
 $E=2e5$ MPa, $\nu=0.3$, Density= 7700Kg /m^3

Case a) Solid Rotating Disc

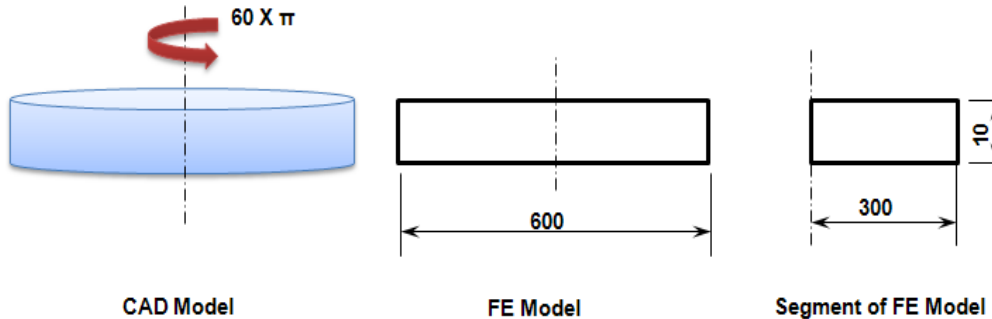

- Preprocessor > Material props > Material models > Structural > Density = 7700 > OK
- Define loads > Apply > Structural > Inertia > Ang.velocity > Global > Global Cartesian Y Comp = 60×3.142 (rad/s)

NOTE: Create axis symmetric model. For consistency it is better to keep all the parameters in terms of meter.

Analytical equations:

$$\sigma_r = \frac{3 + \nu}{8} \rho \omega^2 (b^2 - r^2) \qquad \sigma_\theta = \frac{3 + \nu}{8} \rho \omega^2 b^2 - \frac{1 + 3\nu}{8} \rho \omega^2 r^2$$

These stresses attain their maximum values at the centre of the disk, where

$$\sigma_r = \sigma_\theta = \frac{3 + \nu}{8} \rho \omega^2 b^2$$

RESULT:

Case b) Hollow Rotating Disc

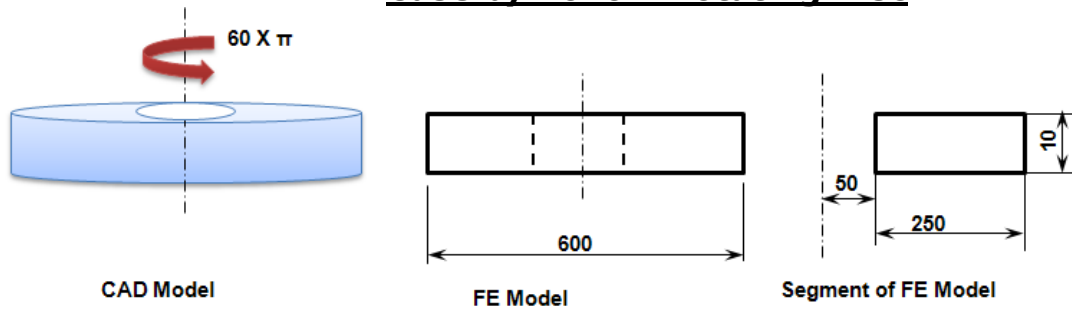

Analytical equations:

$$\sigma_r = \frac{3 + \nu}{8} \rho \omega^2 \left(b^2 + a^2 - \frac{a^2 b^2}{r^2} - r^2 \right)$$

$$\sigma_\theta = \frac{3 + \nu}{8} \rho \omega^2 \left(b^2 + a^2 + \frac{a^2 b^2}{r^2} - \frac{1 + 3\nu}{3 + \nu} r^2 \right)$$

The radial stress σ_r reaches its maximum at $r = \sqrt{ab}$ where

$$(\sigma_r)_{\max} = \frac{3 + \nu}{8} \rho \omega^2 (b - a)^2$$

The maximum circumferential stress is at the inner boundary, where

$$(\sigma_\theta)_{\max} = \frac{3 + \nu}{4} \rho \omega^2 \left(b^2 + \frac{1 - \nu}{3 + \nu} a^2 \right)$$

RESULT:

Chapter 10: INTRODUCTION TO DYNAMIC ANALYSIS

Structural Analysis involves determining the stresses and strains in a structure, when subjected to a variety of loading conditions, under static or dynamic conditions. The term structural (or structure) implies not only naval, aeronautical and mechanical structures such as ship hulls, aircraft bodies and machine housings, as well as mechanical components such as pistons, machine parts, and tools but also civil engineering structures such as bridges and buildings.

The primary unknowns (nodal degrees of freedom) calculated in a structural analysis are displacements. Other quantities, such as strains, stresses, and reaction forces are then derived from the nodal displacement

The large size problems handled by modern digital computers connected with static and dynamic analysis of complicated structures are generally of the form

$$[M]\{\ddot{u}\} + [C]\{\dot{u}\} + [K]\{u\} = F(t)$$

Where [M] is the global mass matrix, [C] the global damping matrix and [K] the global stiffness matrix. {F(t)} is a given forcing function vector in time,

{ \ddot{u} } is the resultant acceleration vector, { \dot{u} } and {u} represent its velocity and displacement vectors respectively. Generally, [M], [C] and [K] are banded. Depending upon the nature of these coefficients, the problems are classified as static, dynamic, linear and non-linear. The following are some of the specific classifications:

When [C] = 0, [M] = 0, [K] and {F(t)} are constants, the result is a static linear problem.

When [M] and [C] are absent, and [K] is a function of {u} and {F(t)} a constant the result is a non-linear static problem.

If {F(t)} and [C] are absent, and [M] and [K] are constants, it is an Eigen value problem.

If [M], [C] and [K] are constants and {F(t)} is a periodic forcing function, the result is a multi-degree of freedom steady state vibration problem

If [M], [C] and [K] are constants and {F(t)} is a function of time, the result is a transient vibration problem.

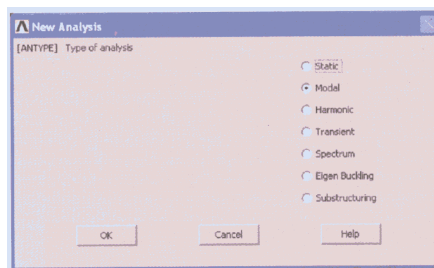

External excitation and the response are time dependent.

Modal Analysis(Eigen Value Problems)

-Used to calculate the natural frequencies and mode shapes of a structure. Different mode extraction methods are available.

Transient Dynamic Analysis-Used to determine the response of a structure to arbitrarily time-varying loads. All nonlinearities mentioned under Static Analysis are allowed.

Harmonic Analysis -Used to determine the response of a structure to harmonically time-varying loads.

Spectrum Analysis -An extension of the modal analysis, used to calculate stresses and strains due to a response spectrum or a PSD input (random vibrations).

Eigen Value Problems

Let $[A]\{u\} = \lambda\{u\}$, where [A] is a symmetric square matrix of size (n x n). There exist 'n' non-trivial solutions for {u} of size (n x 1) each corresponding to 'n' distinct λ values. Values of ' λ '

are known as Eigen values and corresponding $\{u\}$ are the Eigen vectors. Eigen value problems arise in the following cases:

Buckling: $[M] \{\ddot{u}\} + [K] \{u\} = 0$, ' λ_i ' indicates critical/ buckling load and $\{u_i\}$ is the corresponding buckling mode.

Heat Transfer $[K] \{\phi\} = \lambda [C] \{\phi\}$, where $[K]$ is the heat conduction matrix, $[C]$ is the heat capacitance matrix, ' λ ' is the thermal Eigen value and $\{\phi\}$ is the thermal mode shape.

Vibration $\{[K] - \lambda [M]\} \{Q\} = 0$, where $\sqrt{\lambda_i} = \omega_i$ is the i^{th} natural frequency and $\{Q_i\}$ the i^{th} vibration mode.

Eigen values and Eigen vectors can be estimated from the following methods

a. Determinant based methods :

In this method the standard Eigen equation is rewritten as:

$$[A - \lambda I] \{u\} = 0, \{u\} = 0 \text{ is a trivial solution.}$$

For non trivial solution, $\det(A - \lambda I) = 0$

If ' λ ' is a known value and if RHS is replaced by a column vector $\{f\}$ then this gets modified as follows:

$[A - \lambda I] \{u\} = \{f\}$, The displacement vector $\{u\}$ can be evaluated by Cramer's rule.

b. Transformation based

All transformation methods use the same basic formulation. Given $[A] \{u\} = \lambda[U]$, transform $[A]$ into diagonal matrix or tri-diagonal matrix, using a series of matrix transformations of the type $[A] = [T]^T [A] [T]$, where $[T]$ the transformation matrix, is usually an orthogonal matrix, i.e $[T]^T = [T]^{-1}$. If we are able to transform $[A]$ completely into a diagonal matrix, then the elements on the diagonal themselves are the required Eigen values. Transformation methods include Jacobi's method, Given's transformation, Householder's method

c. Vector integration based methods: Vector iteration methods are performed by assuming a trial vector $\{X1\}$. Vector iteration methods include Inverse iteration, Subspace iteration, Power iteration

Free vibration takes place when a system oscillates under the action of forces integral in the system itself due to initial deflection, and under the absence of externally applied forces. The system will vibrate at one or more of its natural frequencies, which are properties of the system dynamics, established by its stiffness and mass distribution. In case of continuous system the system properties are functions of spatial coordinates. The system possesses infinite number of degrees of freedom and infinite number of natural frequencies.

In actual practice there exists some damping (e.g., the internal molecular friction, viscous damping, aero dynamical damping, etc.) inherent in the system which causes the gradual dissipation of vibration energy, and it results in decay of amplitude of the free vibration. Damping has very little influence on natural frequency of the system, and hence, the observations for natural frequencies are generally made on the basis of no damping. Damping is of great significance in restraining the amplitude of oscillation at resonance.

The comparative displacement alignment of the vibrating system for a particular natural frequency is known as the Eigen function in continuous system. The mode shape of the lowest natural frequency (i.e. the fundamental natural frequency) is termed as the fundamental (or the first) mode frequency. The displacements at some points may be zero which are called the nodal points. Generally n^{th} mode has $(n-1)$ nodes excluding the end points. The mode shape varies for different boundary conditions of a beam.

Modal analysis has become a major technique to determine dynamic characteristics of engineering structures and its components. It is a process by which the natural frequencies, mode shapes and damping factor of structures can be determined with a relative ease. The modal analysis process has two types of method to analysis the structures. First is theoretical modal analysis and second is experimental modal analysis.

In the theoretical modal analysis method (fig.1) the spatial properties of the modal (mass, stiffness and damping) are given and using them modal and response modal are obtained. In theoretical modal analysis one cannot forecast accurate boundary conditions, actual rigidity and damping for complex engineering structures and component. So the calculated results often have certain error with actual result. The Numerical modal analysis method using the Finite element modeling softwares like NASTRAN, ANSYS enables engineers to get a better understanding of dynamic properties of structures

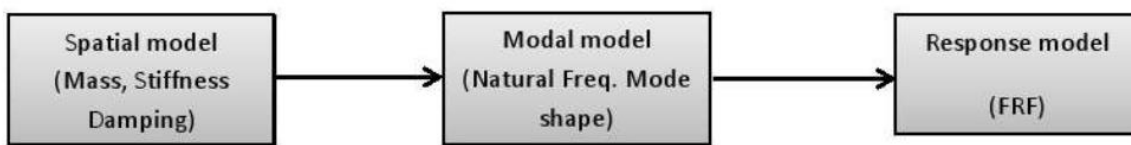

Fig. 1 Theoretical route to vibration analysis

The experimental modal analysis path from response modal (fig 2) and not so often ending with spatial modal. Experimental modal analysis used to derive the modal of a linear time-invariant vibratory system. Modal analysis using vibrometer is non- destructive testing, based on vibration response of the structures. For excitation impact hammer is widely used in modal analysis. It is well known that for structures falling under resonant conditions small force can result in large deformation, and possibly, damage can be induced in the structure. The interaction between the inertial and elastic properties of the materials causes resonant vibration in the structures. Modal is frequently used to find mode of vibration of machine component in the structure.

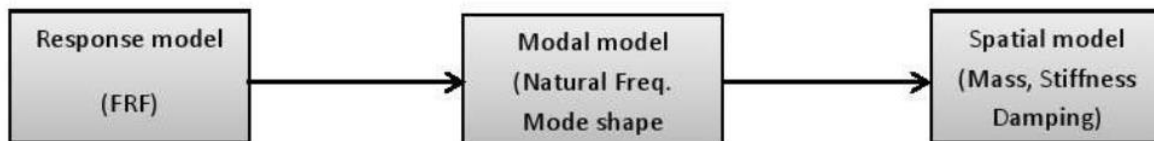

Fig. 2 Experimental route to vibration analysis

In this exercise the modal parameters i.e. natural frequencies and mode shape for the beam are determined using finite element modeling software ANSYS 14.5. The result of thus obtained natural frequencies is then compared with theoretically calculated values.

II. THEORETICAL MODAL ANALYSIS OF BEAM

2.1 Cantilever beam: fixed - free

Consider an Euler-Bernoulli uniform cantilever beam undergoing transverse vibration condition as shown in Fig.3.

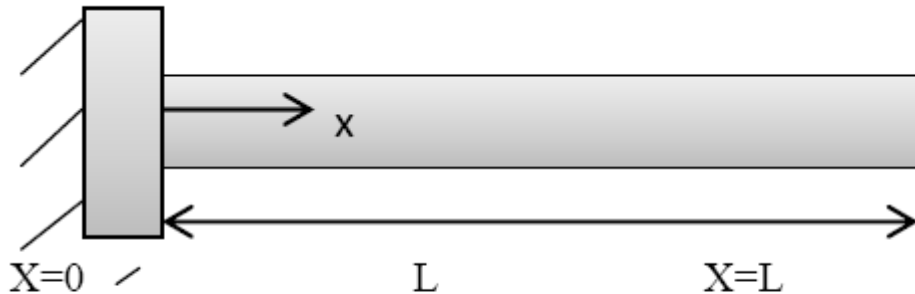

Fig.3 Cantilever Beam

For free vibrations the equation of motion of beam can be given as [6]

$$EI \frac{d^4 w}{dx^4} + \rho A \frac{\partial^2 w}{\partial t^2} = 0 \quad (1)$$

$$c^2 \frac{d^4 w}{dx^4} + \frac{\partial^2 w}{\partial t^2} = 0 \quad (2)$$

$$\text{where } c = \sqrt{\frac{EI}{\rho A}} \quad (3)$$

$$w(x, t) = w(x)T(t) \quad (4)$$

$$\frac{c^2}{w} \frac{d^4 w}{dx^4} T = -\frac{1}{T} \frac{d^2 T}{dt^2} = a \quad (5)$$

Where $\alpha = \omega^2$ can be shown as a constant. The equation (5) can be written as two equations

$$\frac{d^4 w(x)}{dx^4} - \beta^4 w(x) = 0 \quad (6)$$

Where

$$\beta^4 = \frac{\rho A \omega^2}{EI} \quad (7)$$

$$\frac{d^2 T(t)}{dt^2} + \omega^2 T(t) = 0 \quad (8)$$

From the equation (7) the natural frequency of beam ω can be written as

$$\omega = (\beta L)^2 \sqrt{\frac{EI}{\rho A L^4}} \quad (9)$$

The solution of equation (8) is

$$T(t) = A \cos \omega t + B \sin \omega t \quad (10)$$

Where A and B are constant that can be determined from the initial boundary conditions.

Assuming the solution of equation (6) as

$$W(x) = C e^{\beta x} \quad (11)$$

Using (6) and (11) one can obtain the general solution

$$W(x) = C_1(\cos \beta x + \cosh \beta x) + c_2(\cos \beta x - \cosh \beta x) \\ + c_3(\sin \beta x + \sinh \beta x) + c_4(\sin \beta x - \sinh \beta x) \quad (12)$$

Where, the constants $C_1, C_2, C_3,$ and C_4 can be determined from the boundary conditions. For a **cantilever beam** the

transverse deflection and its slope must be zero at the fixed end and at free end the bending moment and shear force must be zero.

Thus the boundary conditions become

$$W(0) = 0 \quad (13)$$

$$\frac{dW}{dx}(0) = 0 \quad (14)$$

$$\frac{d^2W}{dx^2}(L) = 0 \quad (15)$$

$$\frac{d^3W}{dx^3}(L) = 0 \quad (16)$$

Substituting the equation from (13) to (16) in equation (12) to obtain

$$\cos\beta L + \cosh\beta L + 1 = 0 \quad (17)$$

Equation (17) is the frequency equation. This transcendental equation can be solved to obtain the value of $(\beta L)^2$ and for the cantilever beam the values are given in Table 1 [5].

Table1 The value of βl^2

Mode	$(\beta L)^2$
Mode 1	1.875104
Mode 2	4.694091
Mode 3	7.854757

Note: Refer appendix on the page No 234

2.2 Free-Free beam

The beam is free at both end as shown in fig. 4. At a free end, the bending moment and shear force are zero. Hence, the boundary condition of the beam can be stated as

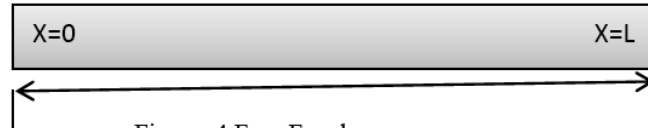

Figure: 4 Free-Free beam

$$EI \frac{d^2 w(0)}{dx^2} = 0 \text{ or } \frac{d^2 w(0)}{dx^2} = 0 \quad (18)$$

$$EI \frac{d^3 w(0)}{dx^3} = 0 \text{ or } \frac{d^3 w(0)}{dx^3} = 0 \quad (19)$$

$$EI \frac{d^2 w(L)}{dx^2} = 0 \text{ or } \frac{d^2 w(L)}{dx^2} = 0 \quad (20)$$

$$EI \frac{d^3 w(L)}{dx^3} = 0 \text{ or } \frac{d^3 w(L)}{dx^3} = 0 \quad (21)$$

$$\frac{d^2 w(x)}{dx^2} = \beta^2 [c_1(-\cos\beta x + \cosh\beta x) + c_2(-\cos\beta x - \cosh\beta x) + c_3(-\sin\beta x + \sinh\beta x) + c_4(-\sin\beta x - \sinh\beta x)]$$

$$\frac{d^3 w(x)}{dx^3} = \beta^3 [c_1(-\sin\beta x + \sinh\beta x) + c_2(\sin\beta x - \sinh\beta x) + c_3(-\cos\beta x + \cosh\beta x) + c_4(-\cos\beta x - \cosh\beta x)]$$

Equation(18)and(19) require that

$$c_2 = c_4 = 0 \quad (24)$$

In equation(18) , (20)and(21) lead to

$$c_1(-\cos\beta l + \cosh\beta l) + c_3(-\sin\beta l + \sinh\beta l) = 0 \quad (25)$$

$$c_1(\sin\beta l + \sinh\beta l) + c_3(-\cos\beta l + \cosh\beta l) = 0 \quad (26)$$

c_1 and c_3 in equation (25) and (26) the determine formed by their coefficient is set equal to zero.

$$\cos\beta l \cosh\beta l - 1 = 0 \quad (27)$$

Equation (27) is the frequency equation. This transcendental equation can be solved to obtain the value of $(\beta L)^2$ and for the free-free beam the values are given in Table 2[5].

Table:2 The Value of $(\beta l)^2$

Modal	$(\beta l)^2$
Modal 1	0
Modal 2	4.730041
Modal 3	7.853205

2.3 Fixed-Fixed Beam

At a fixed end, the transverse of the displacement are zero hence, the boundary condition are given by

$$W(0)=0 \quad (28)$$

$$\frac{dw}{dx}(0) = 0 \quad (29)$$

$$W(L)=0 \quad (30)$$

$$\frac{dw}{dx}(l) = 0 \quad (31)$$

Equation (28) and (29)

$$c_1 = c_2 = 0 \quad (32)$$

Equation (30) and (31)

$$c_2(\cos\beta l - \cosh\beta l) + c_4(\sin\beta l - \sinh\beta l) = 0 \quad (33)$$

$$c_2(\sin\beta l + \sinh\beta l) + c_4(\cos\beta l - \cosh\beta l) = 0 \quad (34)$$

Equation (33)and(34) denote a system of two homogeneous algebraic equation determine of the coefficients of c_2 and c_4 in equation (33) and(34) to zero.

Frequency equation as

$$\cos\beta l \cosh\beta l - 1 = 0 \quad (35)$$

Equation (35) is the frequency equation. This transcendental equation can be solved to obtain the value of $(\beta L)^2$ and for the fixed-fixed beam the values are given in Table 3 [5].

Table:3 The Value of $(\beta l)^2$

Modal	$(\beta l)^2$
Modal 1	4.730041
Modal 2	7.853205
Modal 3	10.995608

The material and geometric parameter used for theoretical and FEM analysis of beam are tabulated in Table 4.

Table 4: Material and geometric parameter

Material Parameter	Geometric Parameter
$E = 20.5 \times 10^{10} N/M^2$	$L = 2m$
$\rho = 7830 kg/m^3$	$B=0.3m$
$V=0.33$	$H=0.1m$

Table: 5 Theoretical and numerically natural frequency of beam

End conditions	Mode	Analytically frequency (Hz)	Natural frequency (Hz)	FEMNatural frequency (Hz)
Free - Free	1	0		0
	2	130.90		130.59
	3	356.3339		356.00
Fixed - Free	1	20.54		20.818
	2	129.24		129.25
	3	357.56		357.05
Fixed - Fixed	1	132.04		132.04
	2	357.3022		357.80
	3	687.72		687.19

The numerical mode shape and corresponding natural frequency obtained using ANSYS are shown in fig.5-7.

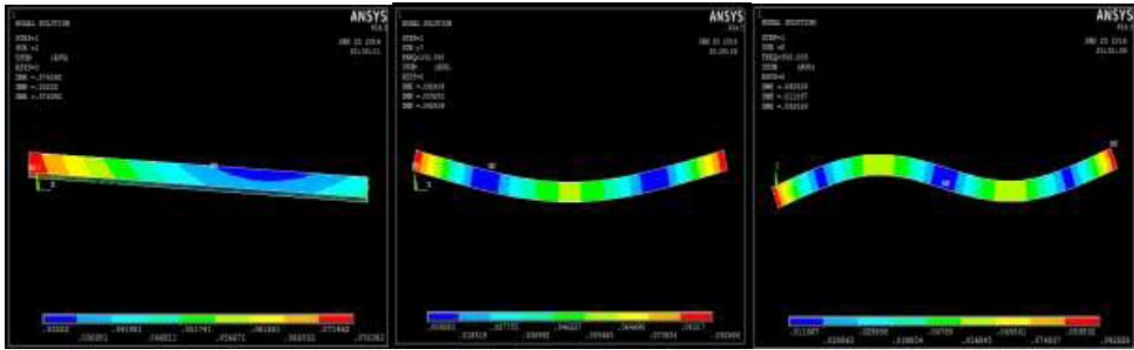

(1) (2) (3)

Figure 5: Mode shape and corresponding frequency for free - free boundary condition

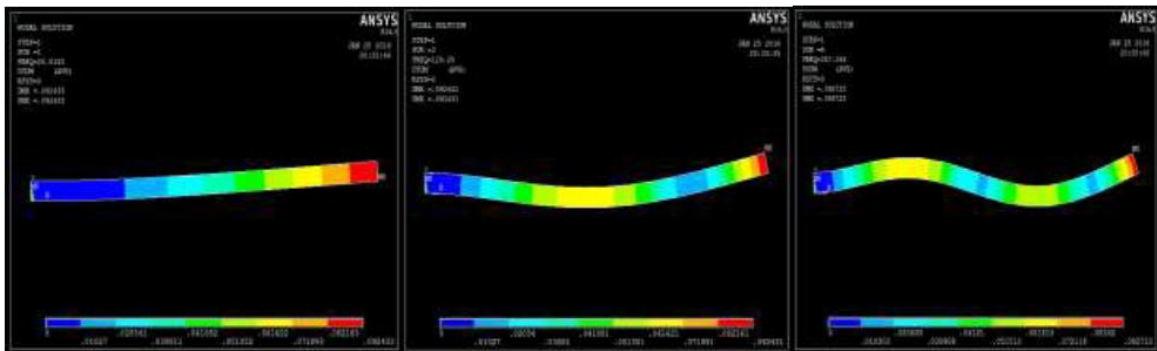

(1) (2) (3)

Figure 6: Mode shape and corresponding frequency for fixed - free boundary condition

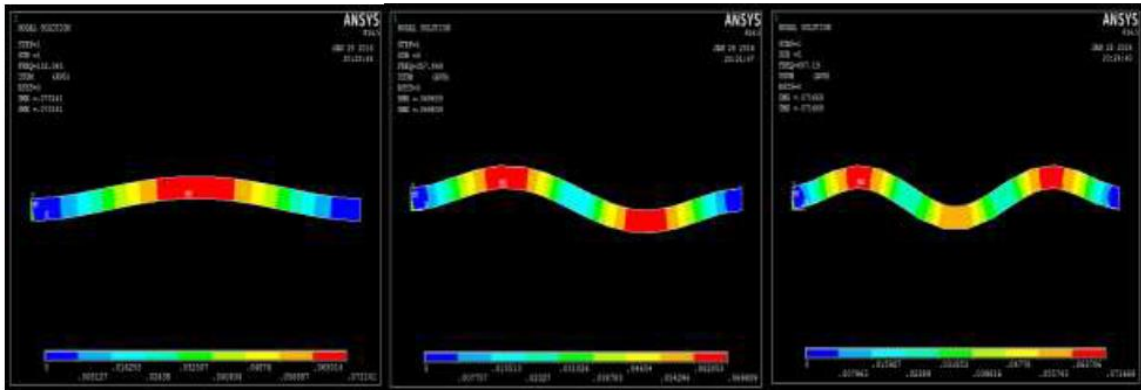

(1) (2) (3)

Figure 7: Mode shape and corresponding frequency for fixed - fixed boundary condition

IV. NUMERICAL MODAL ANALYSIS OF BEAM

The three-dimensional finite element model of beam is constructed in ANSYS 14.5 and then computational modal analysis is performed to generate natural frequencies and mode shapes [10]. The geometric and material parameter is taken from the Table 4 [8]. Solid 185 element are adopted for beam analysis. Relevant boundary conditions are applied at the end of beam [9]. The FEM results are compared to theoretical results.

V. RESULTS AND DISCUSSION

The results of the theoretical natural frequencies and FEM obtained natural frequencies of mild steel, beam are calculated using the material properties and dimensions of the beam given in Table 4. The theoretical natural frequencies are calculated using the equation (9) and the finite element natural frequencies are determined using ANSYS 14.5. Table 5 depicts the theoretical, numerical and natural frequencies of the beam. To validate FEM result theoretical modal analysis carried out.

Table: 5 Theoretical and numerically natural frequency of beam

End conditions	Mode	Analytically frequency (Hz)	Natural frequency (Hz)	FEMNatural frequency (Hz)
Free - Free	1	0		0
	2	130.90		130.59
	3	356.3339		356.00
Fixed - Free	1	20.54		20.818
	2	129.24		129.25
	3	357.56		357.05
Fixed - Fixed	1	132.04		132.04
	2	357.3022		357.80
	3	687.72		687.19

The numerical mode shape and corresponding natural frequency obtained using ANSYS are shown in fig.5-7.

Steps in a Modal Analysis :

Modal analysis is to determine the vibration characteristics (natural frequencies and mode shapes) of a structure or a Machine Component while it is being designed. Modal analysis outputs can be used as input for the following analysis. Transient dynamic analysis, Harmonic response analysis, Spectrum analysis.

The procedure for a modal analysis consists of four main steps:

Build the model > Apply loads and obtain the solution > Expand the modes > Review the results.

Build the model

The geometry can either be created within ANSYS or imported. Only linear behavior is valid in a modal analysis. Define both Young's modulus (EX) (or stiffness in some form) and density (DENS) (or mass in some form) for a modal analysis

Apply Loads and Obtain the Solution

Define Analysis Type: Modal

Analysis option

Choose one of the extraction methods listed below.

Block Lanczos method (default) -used for large symmetric eigenvalue problems. It uses the sparse matrix solver, overriding any solver specified already

Subspace method -used for large symmetric eigenvalue problems.

When doing a modal analysis with a large number of constraint equations, use the subspace method with the frontal solver instead of the JCG solver.

The Power Dynamics method -used for very large models (100,000+DOFs), and is especially useful to obtain a solution for the first several modes to learn how the model will behave. You can then choose the most appropriate extraction method (subspace or Block Lanczos) for running the final solution.

Reduced method is faster than the subspace method because it uses reduced (condensed) system matrices to calculate the solution. However, it is less accurate because the reduced mass matrix is approximate.

Unsymmetric method -used for problems with unsymmetrical matrices, such as fluid-structure interaction problems.

Damped method -used for problems where damping cannot be ignored, such as bearing problems

QR Damped method -faster and achieves better calculation efficiency than the damped method. It uses the reduced modal damped matrix to calculate complex damped frequencies in modal coordinates.

For most applications, you will use the Block Lanczos, subspace, reduced, or Power Dynamics method. The unsymmetric, damped, and QR damped methods are meant for special applications.

Apply Loads

The only "loads" valid in a typical modal analysis are zero-value displacement constraints. You can specify forces, pressures, temperatures, accelerations, and so on in a modal analysis, but they are ignored for the mode extraction. However, the program will calculate a load vector and write it to the mode shape file (Jobname.MODE), so that it can be used in a subsequent mode-superposition harmonic or transient analysis.

Output

The output from the solution consists mainly of the natural frequencies, which are printed as part of the printed output (Jobname.OUT) and also written to the mode shape file (Jobname.MODE).The printed output may include reduced mode shapes and the Participation factor table, depending on the analysis options and output controls. The mode shapes are not written to the database or to the results file, so you need to expand the modes to post process the results.

Expand Mode

The term "expansion" means expanding the reduced solution to the full DOF set. The "reduced solution" is usually in terms of master DOF. In a modal analysis, however, we use the term "expansion" to mean writing mode shapes to the results file. That is, "expanding the modes" applies not just to reduced mode shapes from the reduced mode extraction method, but to full mode shapes from the other mode extraction methods as well. Thus, if you want to review mode shapes in the postprocessor, you must expand them (that is, write them to the results file).Expanded modes are also required for subsequent spectrum analyses Number of modes to expand can be defined in many ways.

Choose **Preprocessor > Loads>~ Analysis option**. In the Modal Analysis dialog box, enter the "No. of modes to expand" value;

Or Choose **Solution > Load Step Opts > Expansion Pass > Single Expand > Expand Modes**

Review the Results

Results from a modal analysis (that is, the model expansion pass) are written to the structural results file, Job name, RST.

The Results consist of:

Natural frequencies

Expanded mode shapes

Relative stress and force distributions (if requested)

You can review these results in POST1, the general postprocessor. Some typical post processing operations for a modal analysis are described below.

Listing All Frequencies

To list the frequencies of all modes expanded, choose **General Postproc >List Results**

Plotting deformed shape

To define mode shape (deformed shape), choose **General Postproc>Plot Results>Deformed Shape** from the Main menu.

Problem 54: Obtain the first ten natural frequencies of the Fixed –Fixed beam shown in figure and Compare them with theoretical values. Also plot their mode shapes

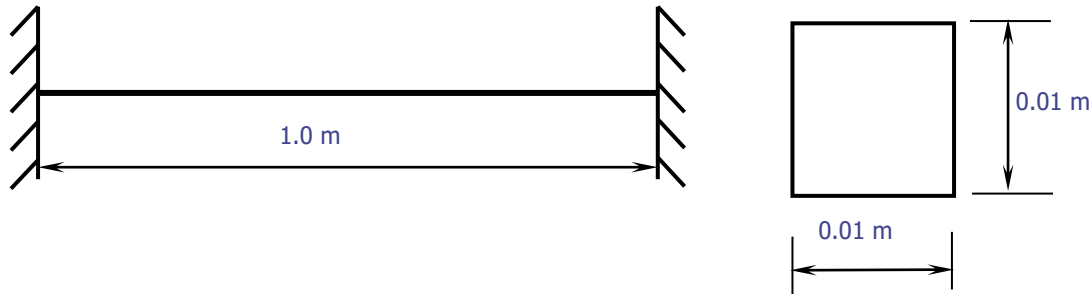

Modulus of elasticity, $E = 2.068 \times 10^{11}$ N/m², Poisson's ratio, = 0.3, Density, = 7830 kg/m³
M.I of I section = , C/S Area =

Preprocessor

1. Define Element Types

Preprocessor > Element Type > Add/Edit/Delet > Beam > 3D Finite Strain > Ok > Options > K3 > select **Cubic Form.** > Ok

2. **Define Area:** Preprocessor > Sections > Beam > Common Sections > B-0.01, H-0.01 > Ok

3. Define Element Material Properties

Preprocessor > Material Props > Material Models > Structural > Linear > Elastic > Isotropic, EX: 2.068e11, Poisson's Ratio, PRXY: 0.3, Density: 7830

4. Preprocessor > Modeling > create > Keypoints > in Active CS

Create 2 Keypoints with the following coordinates

Keypoint	X,Y,Z coord.
1	0,0,0
2	1,0,0

5. Preprocessor > Modeling > Create > Lines > Lines > Straight Line

Click on Keypoint 1 and keypoint 2.

6. Preprocessor > Meshing > Size Cntrls > Manual Size > Lines > All Lines. *For this example 10 element divisions are specified along the line.*

7. Preprocessor > Meshing > Mesh > Lines > Click 'Pick All' in the small window appears

8. Solution > Analysis Type > New Analysis > Modal > Ok > Analysis Options

The following window will appear

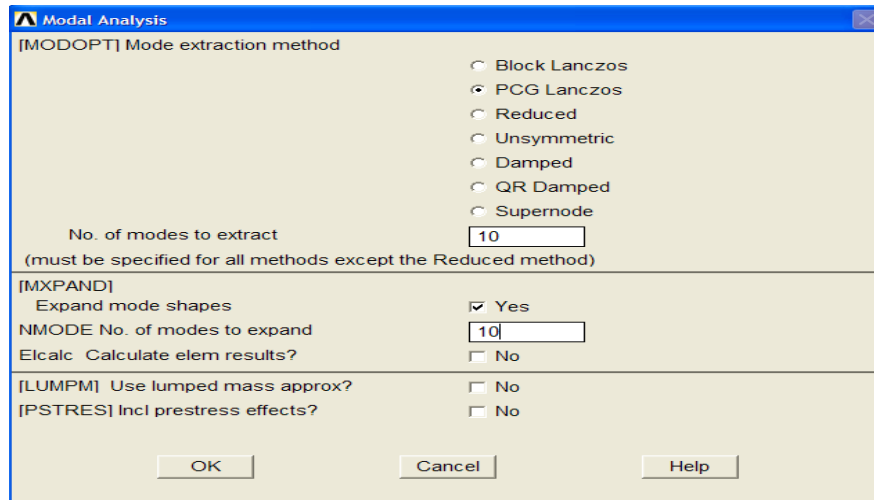

Select the **PGC lanczos** method.
 Enter 10 in the 'No. of modes to extract'
 Check the box beside 'Expand modes shapes'
 Enter 10 in the 'No. of modes to expand'
 Click 'OK'.
 The following window will then appear

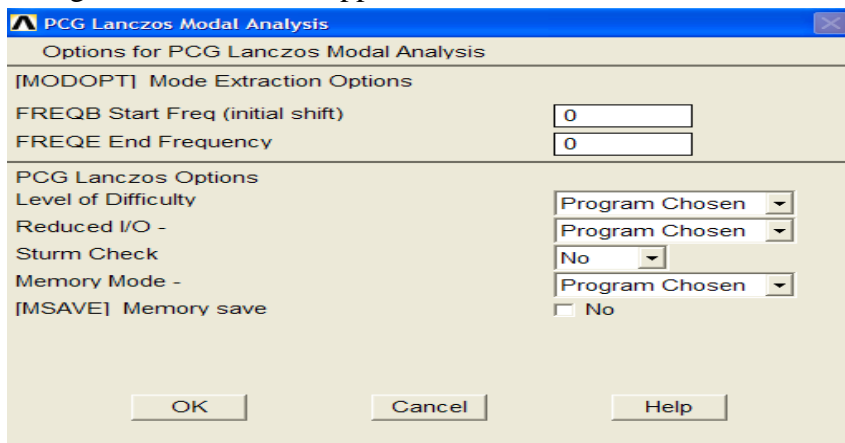

Keep default options in the above window and click on 'OK'.

9. Solution>Define Loads>Apply >Structural>Displacement> On Keypoints

Fix all DOFs constraints on Keypoint 1 and click 'Apply' in a small window that appears. Once you click apply in a small window another window will appear, select 'All DOF' and click apply.

Fix keypoint 2 also for fixed-fixed beam and click 'OK' in small window.

10. Solution>Solve>Current LS

11. General Postproc > Results Summary ...

```

ANSYS,LIST Command
File

***** INDEX OF DATA SETS ON RESULTS FILE *****
SET      TIME/FREQ      LOAD STEP      SUBSTEP      CUMULATIVE
 1      52.790          1              1             1
 2      52.790          1              2             2
 3      145.39          1              3             3
 4      145.39          1              4             4
 5      284.68          1              5             5
 6      284.68          1              6             6
 7      469.89          1              7             7
 8      469.89          1              8             8
 9      700.77          1              9             9
10      700.77          1             10            10

```

The results are compared with theoretical values as shown

$$f_i = (n_i/2\pi) \sqrt{EI/\rho AL^4}$$

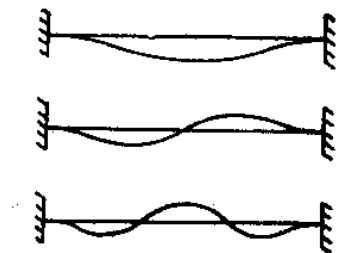

$$\omega_1 = \frac{22.0 a}{l^2}$$

$$\omega_2 = \frac{61.7 a}{l^2}$$

$$\omega_3 = \frac{121.0 a}{l^2}$$

where, $a = \sqrt{\frac{EI}{\rho A}}$

$$f_i = \frac{1}{2\pi} \omega_i \text{ Hz } \quad i = 1,2,3$$

Mode	Natural Frequencies in Hz		Percent Error
	Theory	ANSYS	
1	51.935	52.790	1.7
2	145.654	145.39	0.04
3	285.642	284.68	0.02

12. View Mode Shapes: General Postproc > Read Results > First Set

This select the results for the first mode shape.

General Postproc > Plot Results > Deformed Shapes > Select Def + Undef + edge

The first mode shape is now appear in the graphic window.

To view the next mode shapes, select

General Postproc > Read Results > Next set

General Postproc > Plot Results > Deformed Shapes > Select Def + Undef +edge.

Repeat the above steps for the remaining mode shapes.

13. Animate Mode Shapes: Select Utility Menu (Menu at the top) > PlotCtrls >Animate >Mode Shapes. Then the following window will appear.

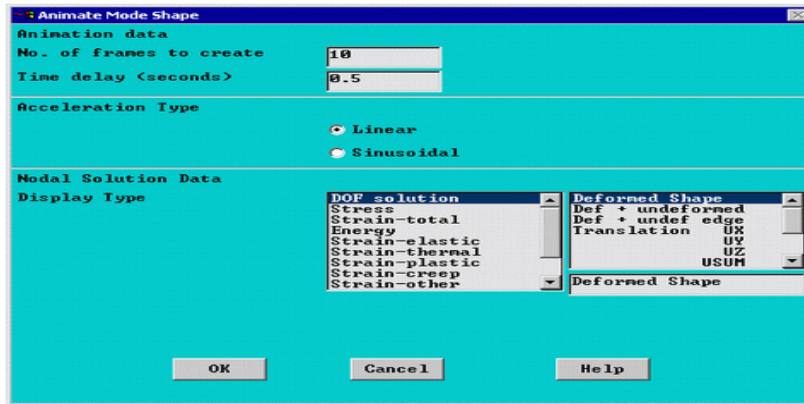

Keeps the default setting and click 'OK', animated window will appear

- Identify the mode of vibration like axial, bending or torsional

Problem 55: Obtain the first three natural frequencies of the Fixed –Fixed beam shown in figure and Compare them with theoretical values. Also plot their mode shapes

Modulus of elasticity, $E = 2.068 \times 10^{11} \text{ N/m}^2$, Poisson's ratio, $= 0.3$, Density, $= 7830 \text{ kg/m}^3$

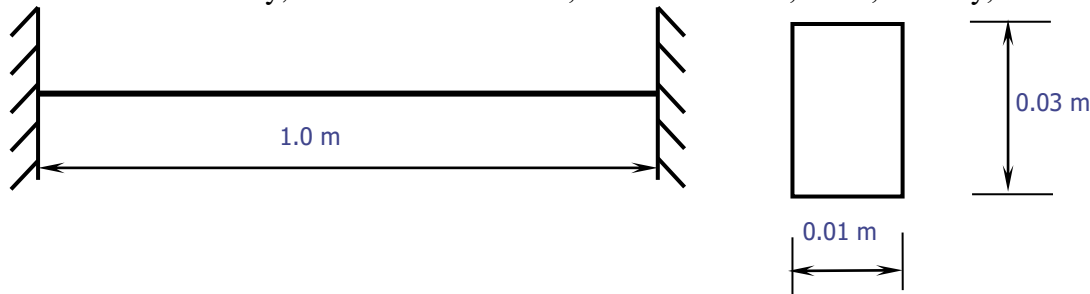

Mode	Natural Frequencies in Hz		Percent Error	Mode Shape
	Theory	ANSYS		
1				
2				
3				

Problem 56: Obtain the first five natural frequencies of the Fixed –Fixed beam having an I cross section with a total depth of 150mm, flange width of 100mm, thickness of flange and web being 25mm. Length of the beam is 1000 mm. Also compare with theoretical values

Modulus of elasticity, $E = 0.7 \times 10^{11} \text{ N/m}^2$, Poisson's ratio, $= 0.3$, Density, $= 2700 \text{ kg/m}^3$

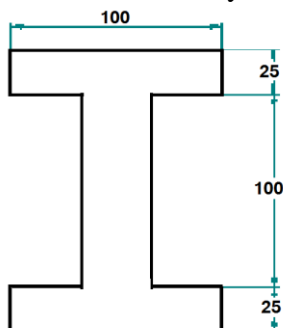

Mode	Natural Frequencies in Hz		Percent Error	Mode Shape
	Theory	ANSYS		
1				
2				
3				

Problem 57: Perform Modal Analysis and find first 3 natural frequencies and mode shapes of the I-Section beam pinned at both ends. Compare the natural frequencies with theoretical ones
 $E = 2.0684 \times 10^5 \text{ MPa}$, $\rho = 7850 \text{ kg/mm}^3$, $\nu = 0.32$

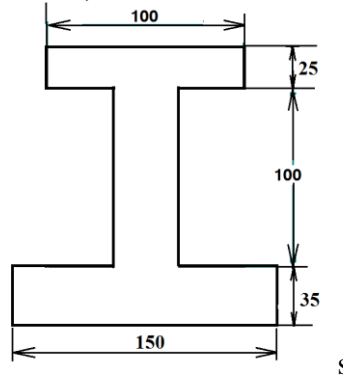

Mode	Natural Frequencies in Hz		Percent Error	Mode Shape
	Theory	ANSYS		
1				
2				
3				

LUMPED SYSTEMS:

In case of shafts and beams of negligible mass carrying concentrated mass, the force is proportional to the deflection of the mass from the equilibrium position and the relation derived for natural frequency of longitudinal vibrations holds good

$$f_n = \frac{1}{2\pi} \sqrt{g / \Delta}$$

Where $\Delta = \frac{mgl^3}{3EI}$ for cantilevers, supporting a concentrated mass at the free end.

$$= \frac{mga^2b^2}{3EI} \text{ for simply supported beams}$$

$$= \frac{mga^3b^3}{3EI} \text{ for beams fixed at both ends}$$

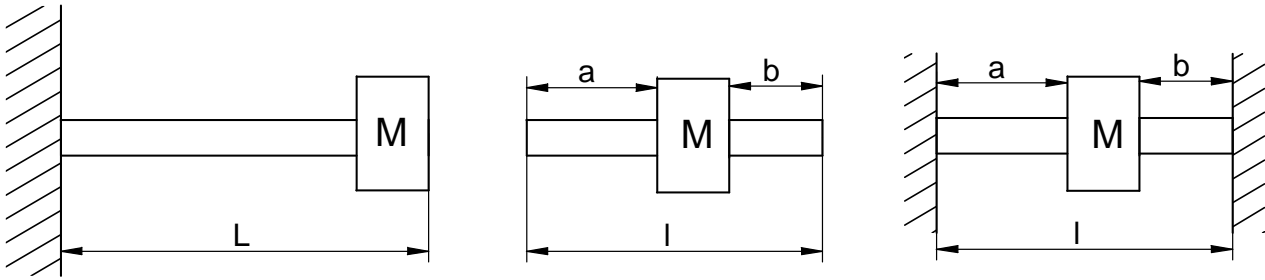

Problem 58: A shaft fixed at the ends has a mass of 120kg placed 250 mm from one end. Determine the frequency of the natural transverse vibrations if the length of the shaft is 700mm, $E = 200\text{GPa}$. and shaft diameter is 40mm. Also compare with theoretical value.

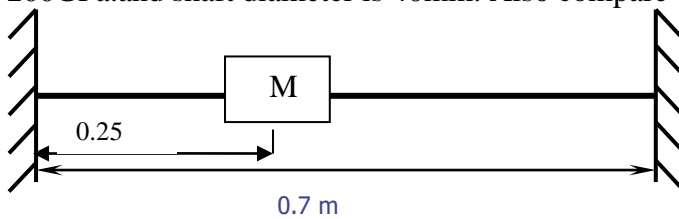

Preprocessor

1. Creation of Fixed Beam used in Modal Analysis:

Give example a Title(optional):Utility Menu > File > Change Title - , *Enter Fixed-Fixed Beam with lumped mass for the title*

Give example a Jobname(optional)::Utility Menu > File > Change Jobname - - , *Enter Modal_5 for the jobname*

2. **Define Element Types:** Preprocessor > Element Type > Add/Edit/Delete > Add > Beam – 3D finite strain > Apply > Structural Mass-3D > mass 21> ok.

Pick Type2 MASS21 > options > Rotary inertia options='2D w/o rot iner' > ok > Close

3. Real Constants> Add/Edit/Delete > Add >Type 2 MASS21 > ok > 2-D mass = 120

4. **Define shaft cross section:** Preprocessor > Sections > Common sections > subtype=circular, $R=20$, ok

5. **Define Element Material Properties:** Preprocessor >Material Props >Material Models > Structural > Linear >Elastic >Isotropic

In the window that appears, enter the following material properties

Young's Modulus, EX : $200\text{e}9$

Poisson's Ratio, PRXY: 0.3

6. **Create Nodes:**Preprocessor>Modeling>create>Nodes>in Active CS

Create 2 Keypoints with the following coordinates

Keypoint	X,Y,Z coord.
1	0,0,0
2	0.25,0,0
3	0.7,0,0

7. **Create Elements:** Preprocessor>Modeling>create>elements>auto numbered >thru nodes> pick1&2,2&3>ok> element attributes >element type number= 2Mass21> ok > auto numbered > thru nodes> pick node 2

8. **Solution > Analysis Type > new analysis > modal>ok>**

Solution > Analysis Type > Analysis Options

The following window will appear

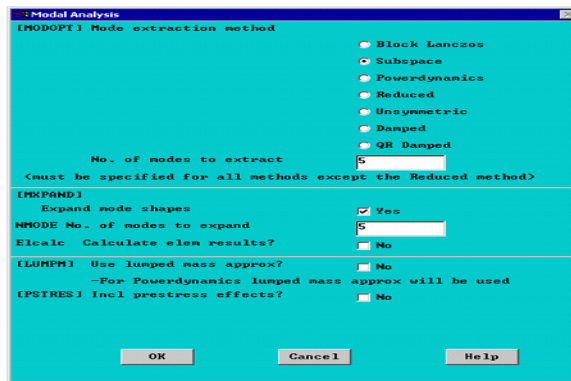

Select the **Subspace** method. Enter 1 in the ‘No. of modes to extract’ Check the box beside ‘Expand modes shapes’ Enter 1 in the ‘No. of modes to expand’ Click ‘OK’.

The following window will then appear

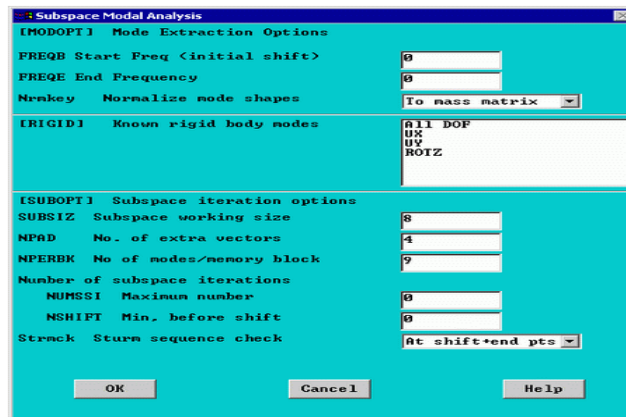

Keep default options in the above window and click on ‘OK’

9. Apply Constraints: Solution > Define Loads>Apply >Structural>Displacement> On Nodes

Fix all DOFs constraints on Nodes1 & 3 and click ok in a small window that appears.

Once you click ok in a small window another window will appear, select ‘All DOF’ and click ok

10. Solve the System: Solution>Solve>Current LS

Post processing

11. Verify Extracted Modes against Theoretical Predictions: General Post proc>Results Summary

12. View Mode Shapes: General Post proc > Read Results > First Set

This select the results for the first mode shape.

General Postproc > Plot Results > Deformed Shapes > Select Def + Undef + edge

The first mode shape will appear in the graphic window.

Mode	Natural Frequencies in Hz		Percent Error	Mode Shape
	Theory	ANSYS		
1				

Problem 59: A shaft supported freely at the ends has a mass of 120kg placed 250 mm from one end. Determine the frequency of the natural transverse vibrations if the length of the shaft is 700mm, E = 200GPa and shaft diameter is 40mm. Also compare with theoretical value.

Mode	Natural Frequencies in Hz		Percent Error	Mode Shape
	Theory	ANSYS		
1				

Problem 60: Obtain the first three natural frequencies of the Fixed –Fixed beam with a central lumped mass as shown in figure and Compare them with theoretical values. Also plot their mode shapes. Modulus of elasticity, $E = 2.068 \times 10^{11} \text{ N/m}^2$, Poisson's ratio, $\nu = 0.3$, Density, $\rho = 7830 \text{ kg/m}^3$
 $I_{NA} =$

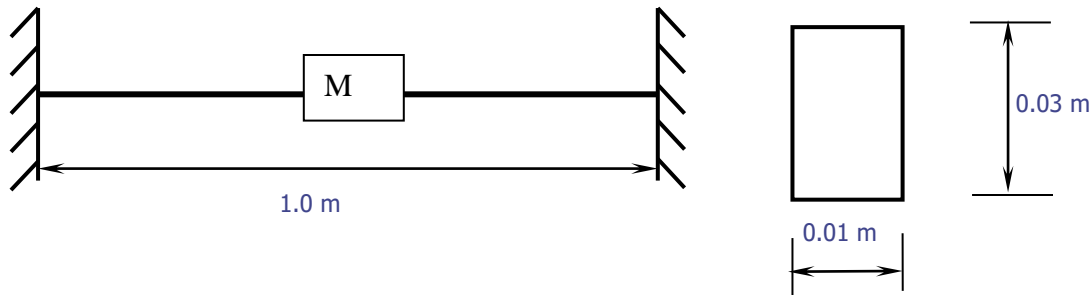

Mode	Natural Frequencies in Hz		Percent Error	Mode Shape
	Theory	ANSYS		
1				

Problem 61: A shaft 40mm diameter and 2.5m long has a mass of 15 kg per meter length. It is simply supported at the ends and carries three masses 90kg, 140kg and 60kg at 0.8m, 1.5m respectively from the left support. Taking $E = 200 \text{ GPa}$, find the frequency of the transverse vibrations.

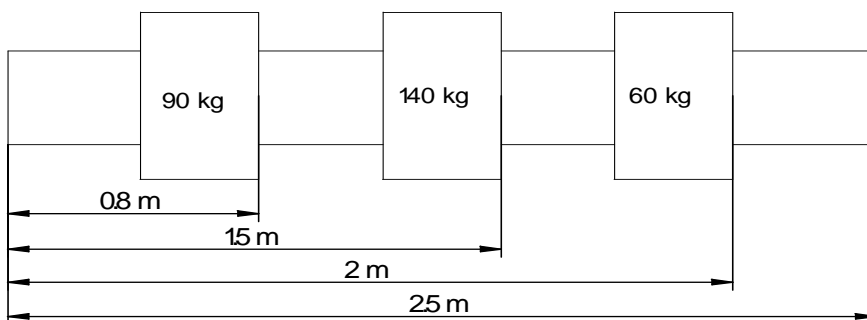

Hint: In order to account the mass of the shaft, calculate the density of the shaft and use it in material model.

Analytical Solution:

$$D = 40 \text{ mm} = 0.04 \text{ m} \quad l = 2.5 \text{ m}$$

$$I \frac{\pi}{64} X d^2 = \frac{\pi}{64} X (0.04)^4 = 0.1257 X 10^{-6} m^4$$

$$f_n = \frac{0.4985}{\sqrt{\Delta_1 + \Delta_1 + \Delta_1 + \frac{\Delta_s}{1.27}}} \quad \Delta_1 = f_n = \frac{mg a^2 b^2}{3EI}$$

Here m =90kg, a= 0.8m and b=1.7m

$$\Delta_1 = \frac{90 X 9.81 X (0.8)^2 X (1.7)^2}{3 X 200 X 10^9 X 0.1257 X 10^{-6} X 2.5} = 0.00866m$$

$$m = 140kg, \quad a = 1.5m \quad b = 1m, \quad \Delta_2 = \frac{140 X 9.81 X (1.5)^2 X (1)^2}{3 X 200 X 10^9 X 0.1257 X 10^{-6} X 2.5} = 0.1639m$$

$$\text{For } \Delta_3 \quad m = 60kg, \quad a = 2m \quad b = 0.5m \quad \therefore \Delta_3 = \frac{60 X 9.81 X (2)^2 X (0.5)^2}{3 X 200 X 10^9 X 0.1257 X 10^{-6} X 2.5} = 0.00312m =$$

$$\Delta_s = \frac{5mg l^4}{384EI} = \frac{5 X 15 X 9.81 X (2.5)^4}{384 X 200 X 10^9 X 0.1257 X 10^{-6}} = 0.00298m$$

$$F_n = \frac{0.4985}{\sqrt{0.00866 + 0.01639 + 0.00312 + \frac{0.00298}{1.27}}} = 2.85Hz$$

Mode	Natural Frequencies in Hz		Percent Error	Mode Shape
	Theory	ANSYS		
1				

Note: Refer page no

Chapter 11: TO CONDUCT HARMONIC ANALYSIS OF A GIVEN AXIAL STEPPED BAR.

Problem 62: Carry out Harmonic analysis for the stepped bar subjected to a cyclic load as shown below.

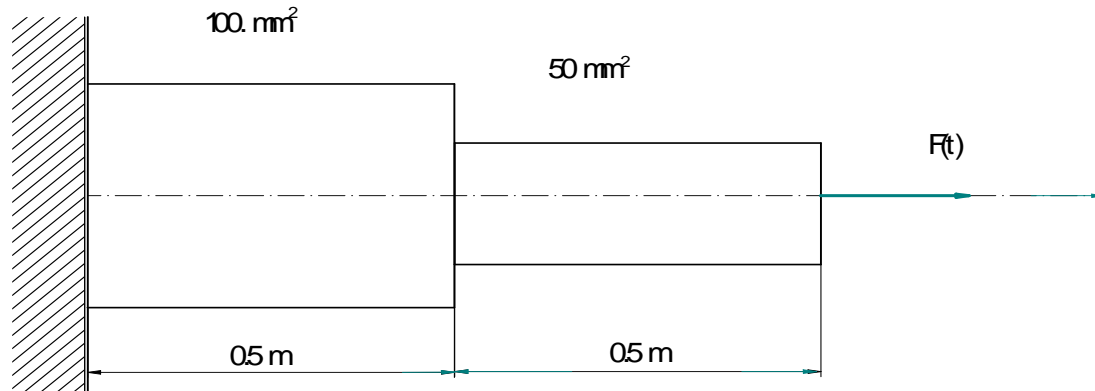

Modulus of elasticity, $E = 2.068 \times 10^{11} \text{ N/m}^2$

Poisson's ratio $\mu = 0.3$

Density, $\rho = 7830 \text{ kg/m}^3$

Load:

Cyclic Load

Magnitude = 100N

Frequency Range: 0-5000 Hz

Note: ANSYS provides 3 methods such as **Full**, **Reduced** and **Modal Superposition** methods for conducting a harmonic analysis. This example demonstrates the full method because it is simple and easy to use as Compared to other methods. However, this method makes use of full stiffness and mass matrices and thus is the slower and costlier option.

PREPROCESSING

1. Define Analysis Type : Solution > Analysis type > New analysis > Harmonic > ok

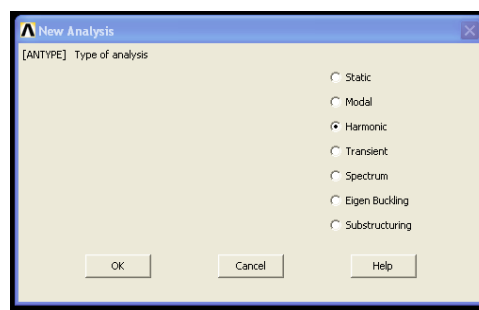

2. Creation of Stepped Bar used in Harmonic Analysis:

Creation of any beam can be obtained through GUI (Graphic User Interface) of ANSYS using the following steps:

- 1 Open preprocessor menu

2. Give example a Title: Utility menu > File > Change Job name--- Enter stepped bar for the title

3. Give example a job name: Utility menu > File > Change Job name--- Enter Dynamic for the jobname

4. Define Element Types

Preprocessor > Element Type > Add/Edit/Delete...

For the problem, the Link (3D Finite stn 180)element is used. This element has 3 d.o.f (i.e. translation along X and Y axes and rotation about Z axis)

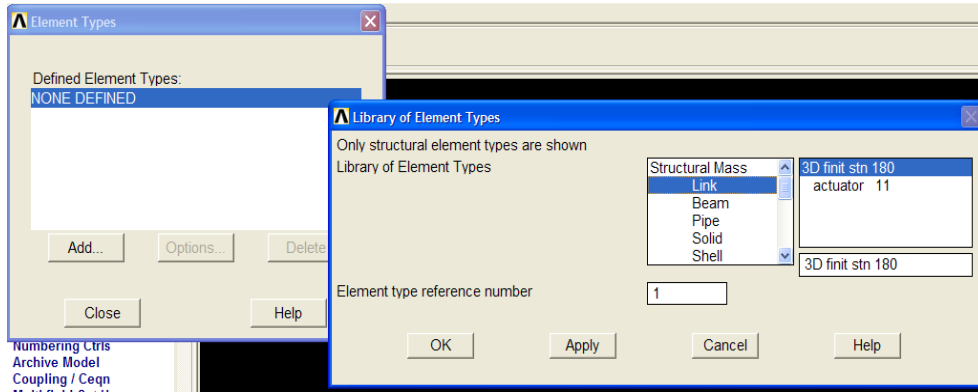

Define Real constant

Preprocessor >Real Constant .>Add. Enter the following 2 steps geometric properties for elements - 1 and 2 For Element 1) Cross sectional area 'AREA' for type 1: 0.0001m² For type 2: 0.0005m²

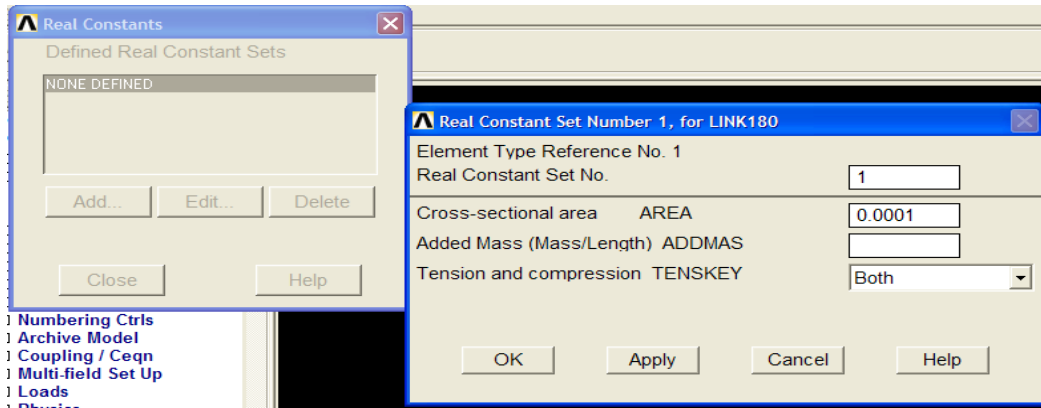

After entering area 1 0.001 click Apply

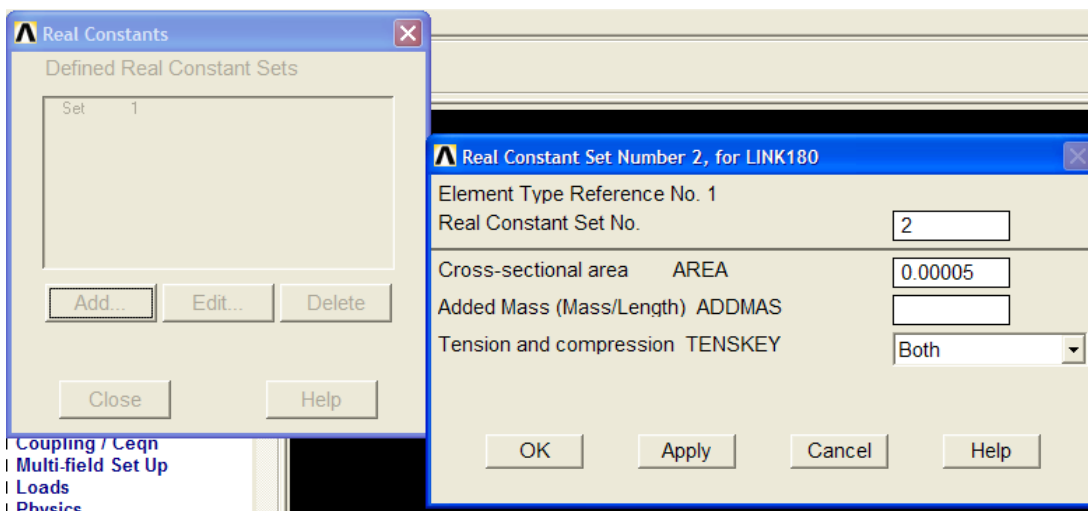

After entering area 2 0.00005 click ok

Note : For dynamic analysis the units of area, Young's modulus density should be in m² N/m² and kg/m³ respectively.

6. Define Element Material Properties

Preprocessor > Material properties > Material Models > Structural > Linear > Elastic > Isotropic in the that appears enter the following material properties of the bar (here it is steel)

- i. Young's Modulus, EX : $2.069 \times 10^{11} \text{ kg/m}^2$
- ii. Poisson's Ratio, PRXY : 0.3

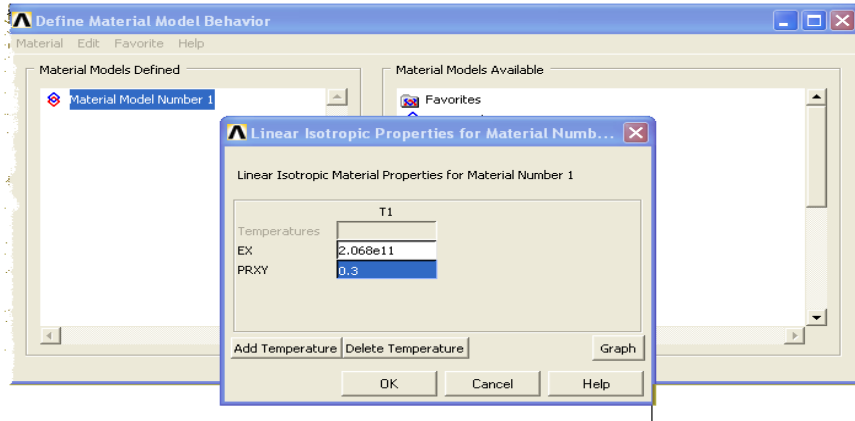

To Enter the density of material ,double click on the 'Linear' followed by 'Density' in the Define Material Model Behavior window and enter a density of 7830 kg/m^3 **divided by 9.81**

Note : If the material properties of two element, create another new model in main menu of the window and enter the material properties of the second element .

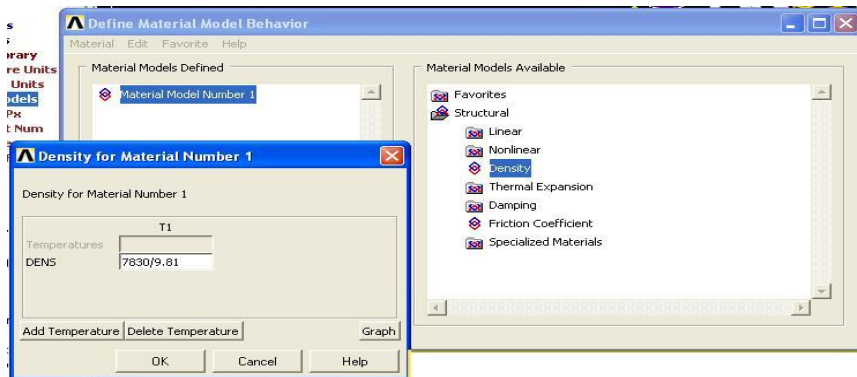

7. Create Nodes

Since the real constant such as area and /or lengths of stepped bar different and number of elements to be used are less, the creation of model through node points is simple as Compared to the creation of model through key points. Hence the model, in this example, is created through nodes.

Preprocessor > Modeling > Create > Nodes > In Active CS

Define 3 node points for this structure along with the coordinates as given in the following table

8. Create Element

Preprocessor > Modeling > Create > Elements > Element Attributes.

Check the material No. and real constant set No. for element 1 in the window that appears (for element 1, both should be 1)

Preprocessor > Modeling > Create > Elements > Auto Numbered > Thru Nodes

* click on node 1 and 2 click 'OK' in small window.

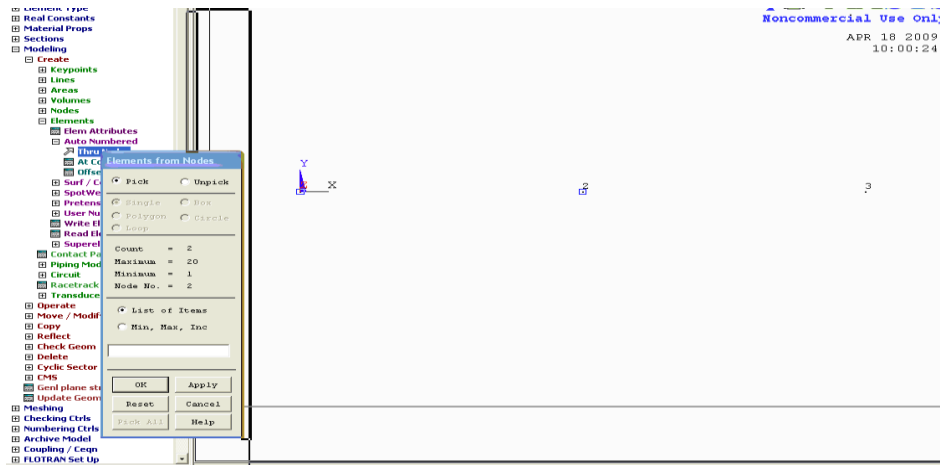
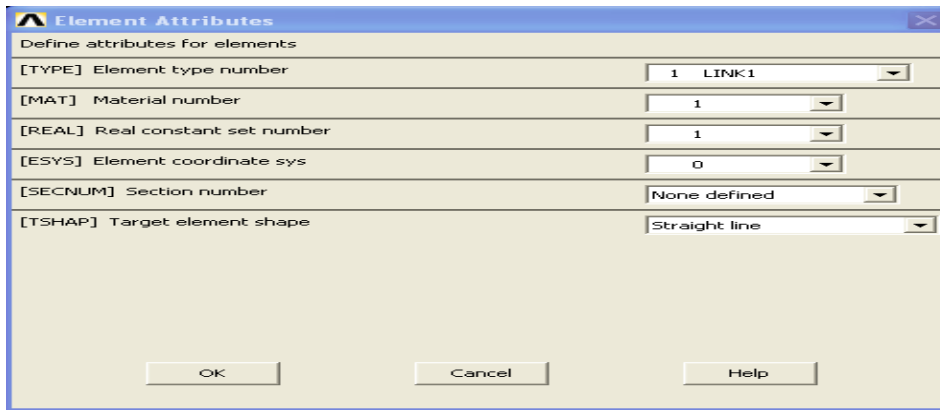

Preprocessor >Modeling >Create>Elements >Element Attributes.

Change the material No. and real constant set No. for element 2 in the window that appears for element 2,Material No.1 and Real Const.Set No.=2, in this case

Preprocessor > Modeling> Create>Elements>Auto Numbered >Thru Nodes

* click on node 2and 3 click 'OK' in small window.

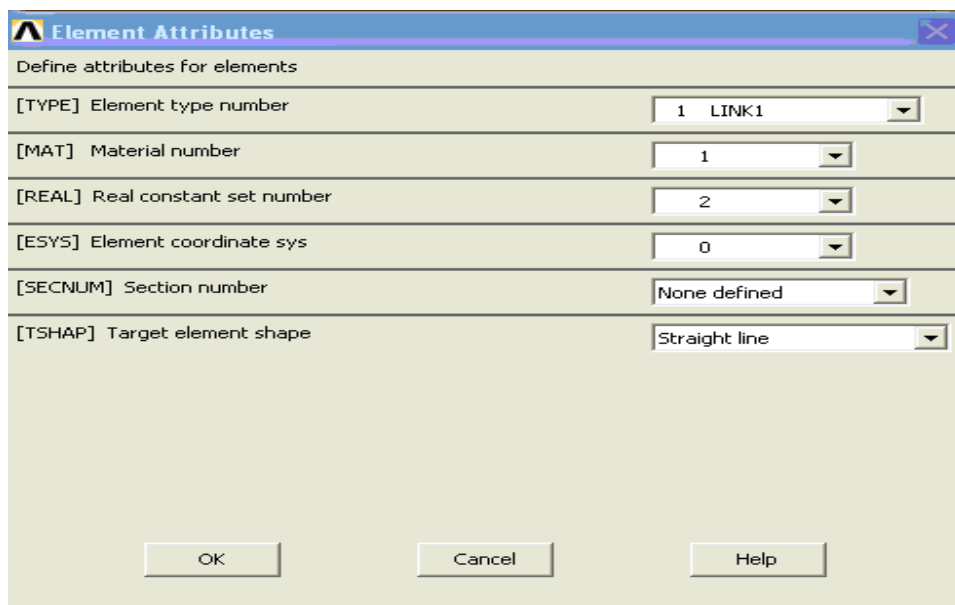

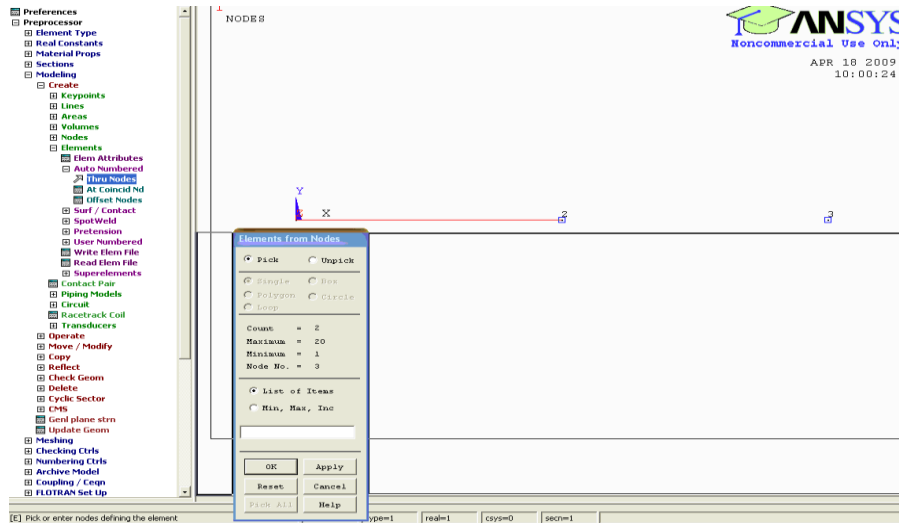

1. Set Options for Analysis Type
 Solution > Analysis Type > Analysis options.....

The following widow will appear (Set next page)

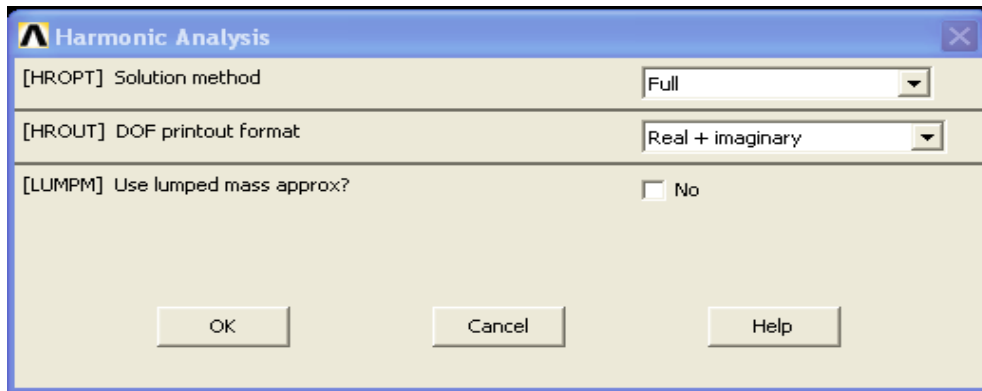

*As shown , Select the Full solution method, the Real +imaginary DOF printout Format and do not use lumped mass approximation.

*Click 'Ok'

The following widow will appear. Use the default setting (shown below)

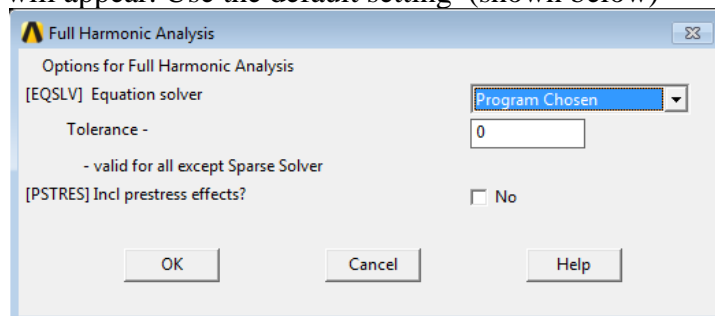

2. Apply Constraints : Solution > Define Load > apply > structural > Displacement > on Nodes
 fix all DOFs constraints on node at x = and click 'Apply' in a small window that appears. Once you click apply in small window another window will appears, select All DOF' and click apply. Fix end node at x =1 also for fixed fixed beam and click 'OK' in small window.

3. Apply Loads: Solution > Define Loads > apply > structural > force/moment > on Nodes

select the node at free-end of bar (i.e. at $x = 1.0$)

The following window will appear. Fill it as shown to apply a load with real value of 100 and an imaginary values of 0 in the positive 'x' direction

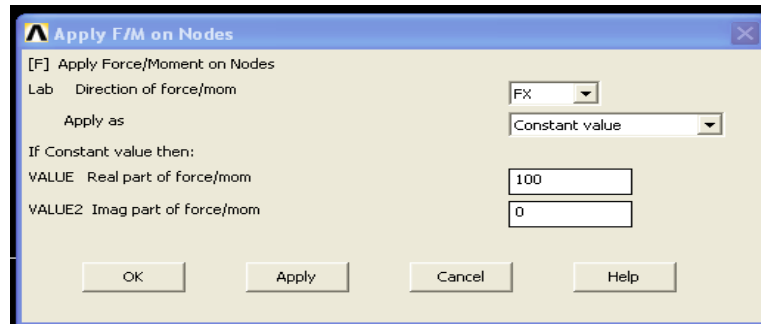

Note: By specifying a real and imaginary value of the load we are providing information on magnitude and phase of the load. In this case the magnitude of the load is 100N and its phase is 0^0 . Phase information is most important when we have two or more cyclic loads being applied to the structure as these load could be in or out phase. For harmonic analysis, all loads must have the same frequency.

4. Set the Frequency Range Solution > Load Step option > Time/Frequency > Freq and Substps....

As shown in the window below, specify a frequency range of 0-4500Hz 100 Sub steps and stepped b.c....

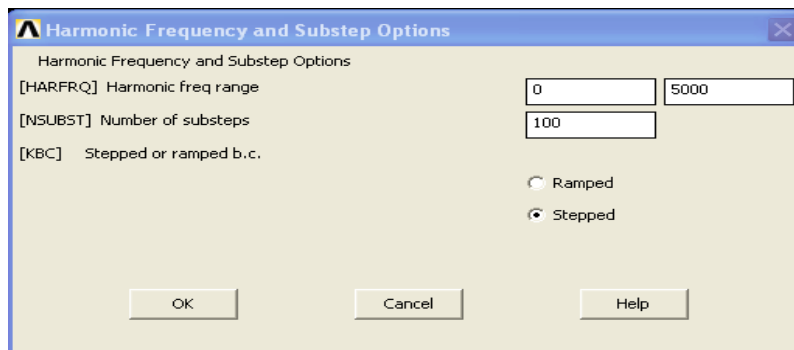

5. Solve the System : Solution > Solve Current LS

SOLVE POSTPROCESSING: Viewing the Results

We want to observe the response $x = 0.5m$ (where the load is applied) as a function of frequency. We cannot do this with General Post processing (POST1), rather we must use Time Hist Post Processing (POST26). post26 is used to observe certain variable as a function of either time or frequency.

1. Open the Time Hist Processing (POST26) Menu Select Time Hist Postprocessor from the ANSYS Main Menu

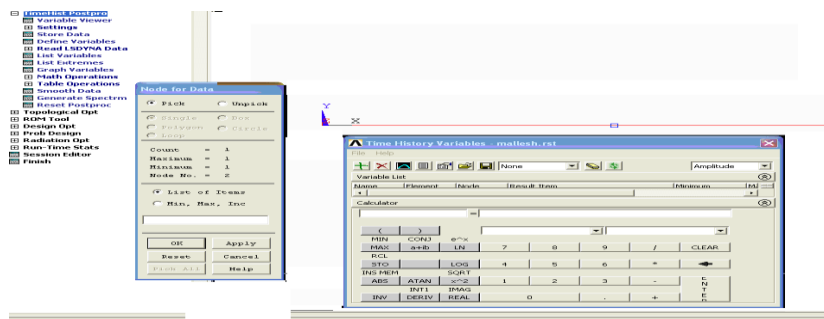

2. Define Variables

Note: Here we have to define variables that we want to see plotted. By default, Variable 1 is assigned either Time or Frequency. In this case it assigned frequency, we want to see the displacement UX at the node at x= 0.5 (To get a list of nodes and their attributes. Select Utility Menu >List Nodes). Time Hist PostPro >Variable Viewer

The following window will pop up.

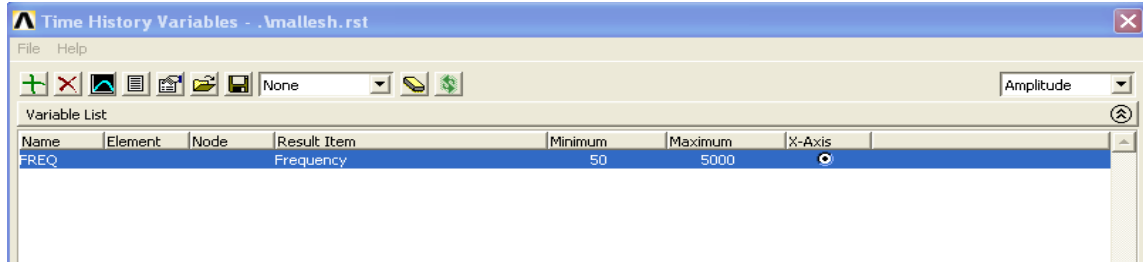

- Select Add (the green '+' sign in the upper left corner) from this window and the following window will appear.

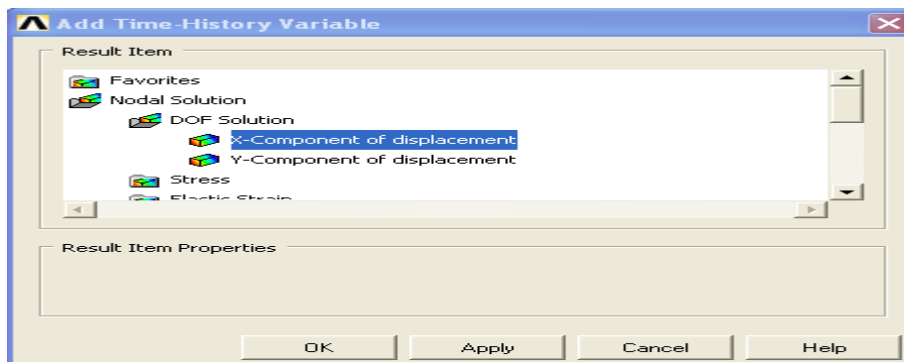

- We are interested in the Nodal Solution >DOF Solution >X-Component. Click OK.
- Graphically select node 2 when promoted and click OK. The 'Time History Variables' window should now look as follows.

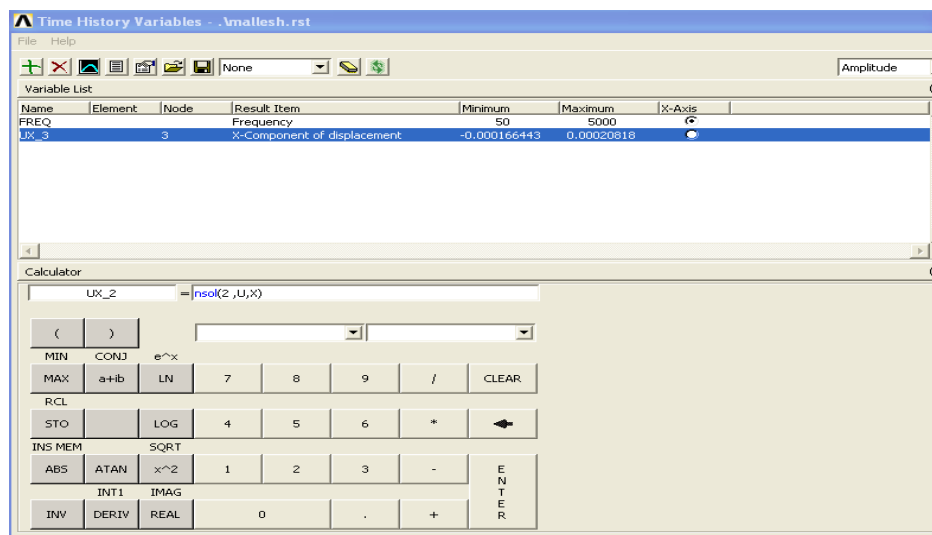

3 List Stored Variables

In the 'Time History Variable' window, click the 'List' button (3 buttons to left of 'Add' button). The following window will appear listing the data:

TIME	UX_3 AMPLITUDE	PHASE
50.000	0.725904E-05	0.000000
100.000	0.727606E-05	0.000000
150.000	0.730463E-05	0.000000
200.000	0.734508E-05	0.000000
250.000	0.739788E-05	0.000000
300.000	0.746363E-05	0.000000
350.000	0.754314E-05	0.000000
400.000	0.763740E-05	0.000000
450.000	0.774764E-05	0.000000
500.000	0.787537E-05	0.000000
550.000	0.802242E-05	0.000000
600.000	0.819106E-05	0.000000
650.000	0.838405E-05	0.000000
700.000	0.860480E-05	0.000000
750.000	0.885754E-05	0.000000
800.000	0.914758E-05	0.000000
850.000	0.948161E-05	0.000000
900.000	0.986826E-05	0.000000

4. Plot UX vs Frequency

* in the 'Time Variable' window click the 'Plot' button (2 buttons to the left of 'Add' button). The following graph will be plotted in the main ANSYS window.

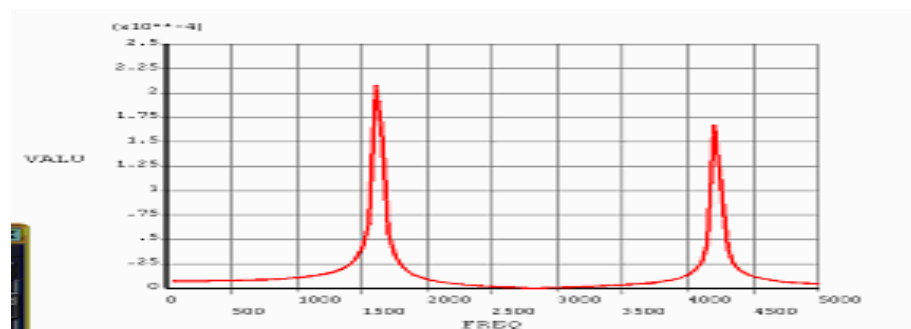

Note that we get peaks at frequencies of approximately 1650 and 4250Hz This correspondence with the predicated natural frequencies of 1627.7 and 4220.5Hz respectively during model analysis of the Same stepped bar.

Obtain the response with log scale of UX similar to the previous case. Then We will now see the response at free-end of bar for the cyclic load with frequency range 0-5000 Hz as shown below. Select Utility menu> Plot Ctrl> Style > Graphs > Modify Axes

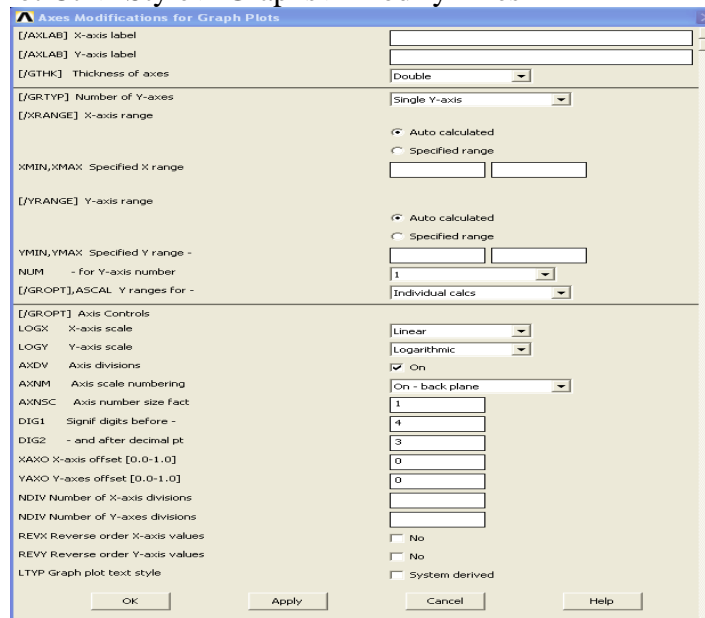

Select Utility Menu > Plot > Replot

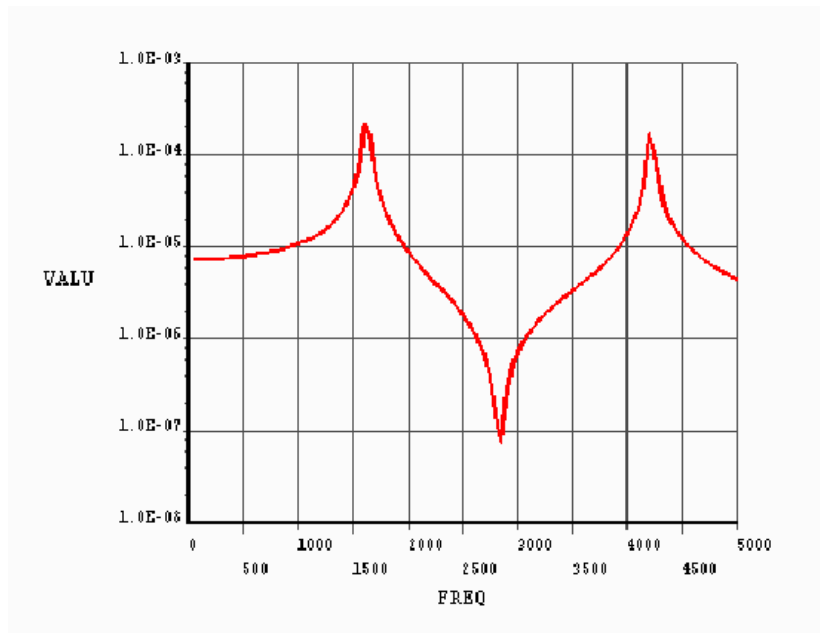

Problem 63: Conduct harmonic analysis of a given axial stepped bar.

Modulus of elasticity, $E = 2.068 \times 10^{11} \text{ N/m}^2$

Poisson's ratio $\mu = 0.3$

Density, $\rho = 7830 \text{ kg/m}^3$

Load: Cyclic Load of 300 KN as shown.

Frequency Range: 0-5000 Hz

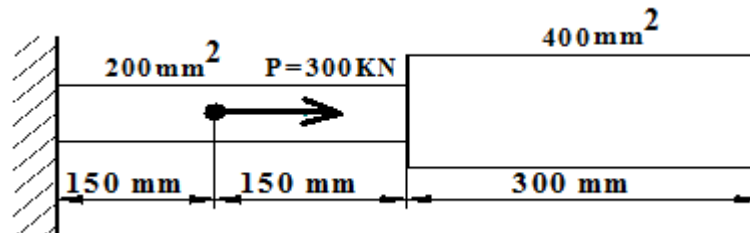

Problem 64: Conduct harmonic analysis of a given axial stepped bar.

Modulus of elasticity, $E = 2.068 \times 10^{11} \text{ N/m}^2$

Poisson's ratio $\mu = 0.3$

Density, $\rho = 7830 \text{ kg/m}^3$

Load: Cyclic Load

Magnitude = 300KN

Frequency Range: 0-800 Hz

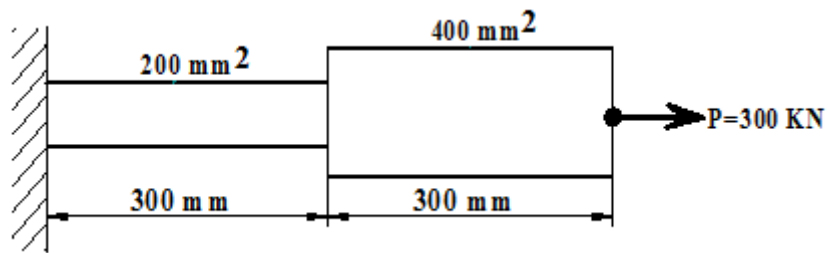

Problem 65: Harmonic analysis of fixed fixed beam

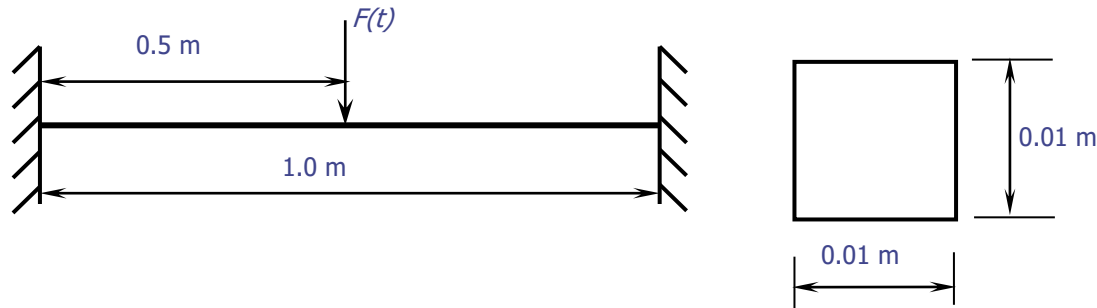

Modulus of elasticity, $E = 2.068 \times 10^{11} \text{ N/m}^2$

Poisson's ratio, $= 0.3$

Density, $= 7830 \text{ kg/m}^3$

M.I of I section $= 8.33 \times 10^{-10} \text{ m}^4$

C/S Area $= 0.0001 \text{ m}^2$

Load: cyclic Load

Magnitude, $F_0 = 100 \text{ N}$

Frequency Range $= 0 - 300 \text{ Hz}$

- 1. Define Analysis Type:** Solution > Analysis type > New analysis > Harmonic > ok
- 2. Define Element Types**
Preprocessor > Element Type > Add/Edit/Delete For this problem, the BEAM (3D Finite strain) element is used.
- 3. Define area:** Preprocessor > Sections > Beam > Common Sections B-0.01, H-0.01 > Ok
- 4. Define Element Material Properties:** Preprocessor > Material Props > Material Models > Structural > Linear > Elastic > Isotropic
In the window that appears, enter the following material properties
Young's Modulus, EX : 2.068×10^{11}
Poisson's Ratio, PRXY: 0.3
Density : 7830
- 5. Create Keypoints:** Preprocessor > Modeling > create > Keypoints > in Active CS > Create Key points with the following coordinates

Keypoint	X,Y,Z coord.
1	0,0,0
2	1,0,0
- 6. Define Lines:** Preprocessor > Modeling > Create > Lines > Lines > Straight Line Click on Keypoint 1 and keypoint 2.
- 7. Define Mesh Size:** Preprocessor > Meshing > Size Cntrl > Manual Size > Lines > All Lines .
For this example 10 element divisions are specified along the line.
- 8. Mesh the Frame:** Preprocessor > Meshing > Mesh > Lines > Click 'Pick All' in the small window appears
- 10. Set Options for Analysis Type**
Solution > Analysis Type > Analysis Options . . .

The following window will appear

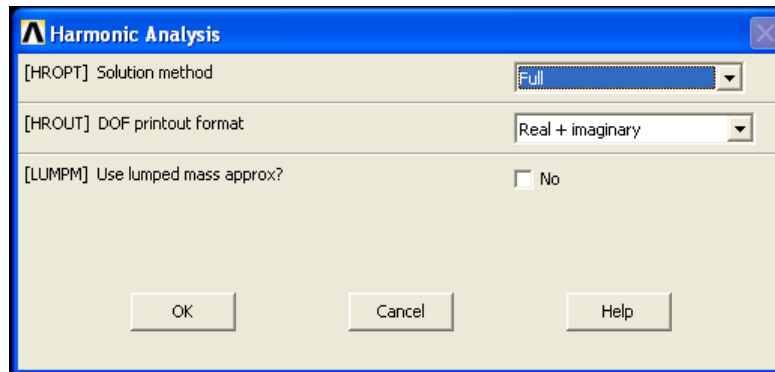

- Select the **Full** solution method, the **Real + imaginary** DOF printout format
- Do not use lumped mass approximation.
- Click 'OK'

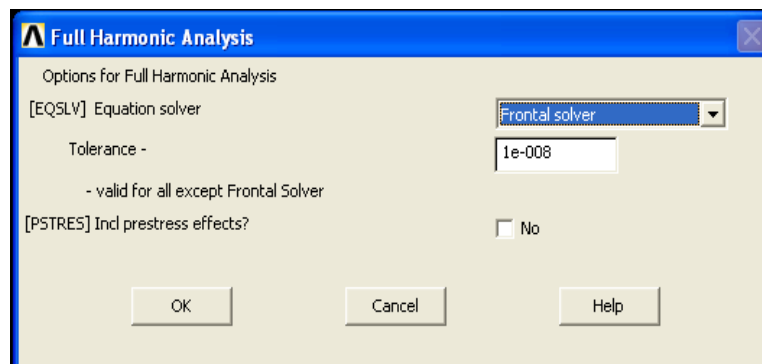

Keep default options in the above window and click on 'OK'.

Apply Constraints: **Solution > Define Loads>Apply >Structural>Displacement> On Nodes**
Fix all DOFs constraints on Keypoint 1 and Keypoint 2.

Apply Load: **Solution > Define Loads > apply > structural > Force/Moment > On Nodes**

Select the node at mid-point of the beam (i.e. at $x=0.5$)

Then the following window will appear.

Fill it as shown to apply a load with real value of 100 and an imaginary value of 0 in the positive 'y' direction.

Set the Frequency Range: **Solution > Load Steo Opts > Time/Frequency > Freq and Substps**

As shown in the window below, specify a frequency range of 0 – 300 Hz, 300 substeps and stepped b.c . . .

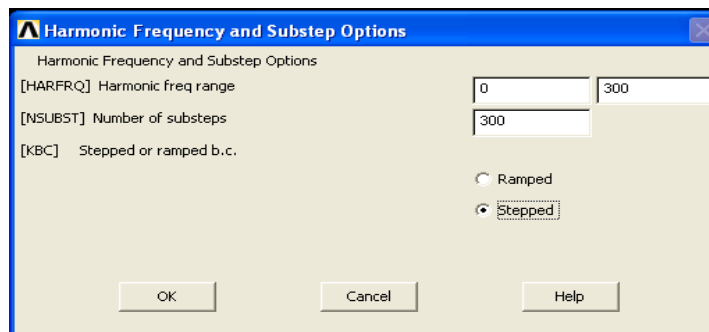

11. Solve the System: Solution > Solve > Current LS

12. Open the TimeHist Processing (POST26) Menu
Define Variables : TimeHist PostPro > Variable Viewer ...
The following window will pop up.

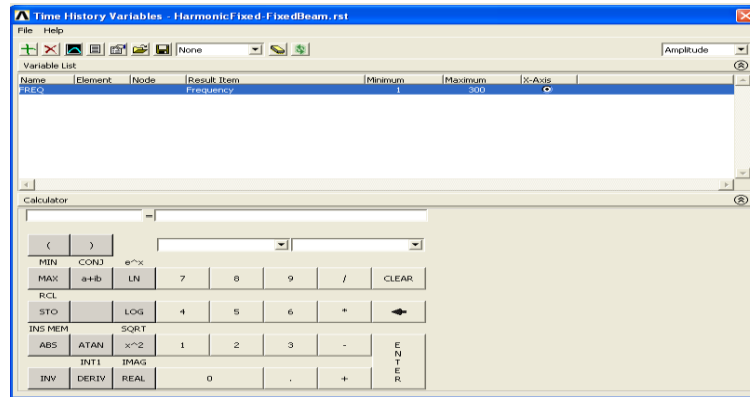

Select Add (the green '+' sign in the upper left corner) from this window and the following window will appear.

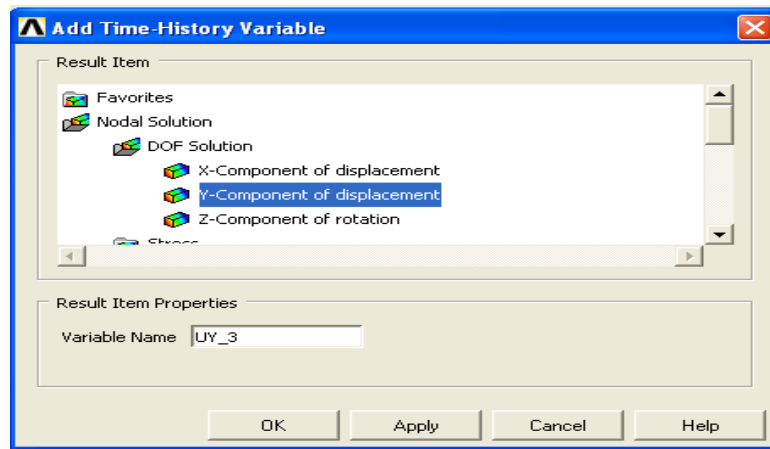

We are interested in the **Nodal solution > DOF Solution > Y – Component**.
Click OK.

Graphically select node 2 when prompted and click OK.

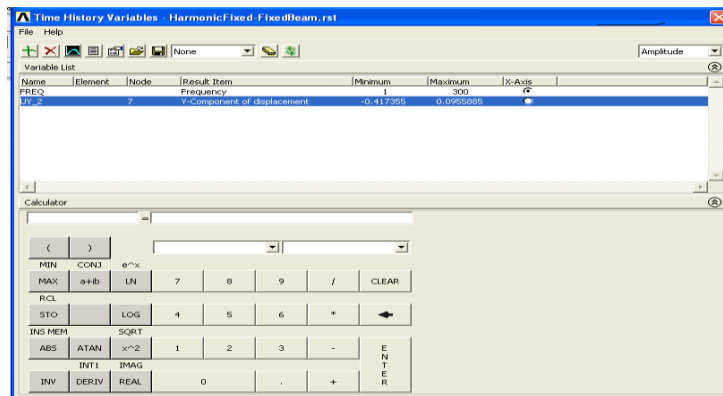

13. List Stored Variables: In the ‘Time History Variable’ window, click the ‘List’ button (3rd buttons to the left of ‘Add’ button).

***** ANSYS POST26 VARIABLE LISTING *****

FREQ	11 UY UY_2 AMPLITUDE	PHASE
1-.0000	0-.291297E-02	180-.000
2-.0000	0-.291594E-02	180-.000
3-.0000	0-.292090E-02	180-.000
4-.0000	0-.292788E-02	180-.000
5-.0000	0-.293691E-02	180-.000
6-.0000	0-.294802E-02	180-.000
7-.0000	0-.296126E-02	180-.000
8-.0000	0-.297669E-02	180-.000
9-.0000	0-.299439E-02	180-.000
10-.000	0-.301443E-02	180-.000
11-.000	0-.303690E-02	180-.000
12-.000	0-.306192E-02	180-.000
13-.000	0-.308961E-02	180-.000
14-.000	0-.312010E-02	180-.000
15-.000	0-.315335E-02	180-.000
16-.000	0-.319014E-02	180-.000
17-.000	0-.323008E-02	180-.000
18-.000	0-.327358E-02	180-.000

14. Plot UY vs Frequency: In the ‘Time Variable’ window click the ‘Plot’ button (2nd buttons to the left of ‘Add’ button).

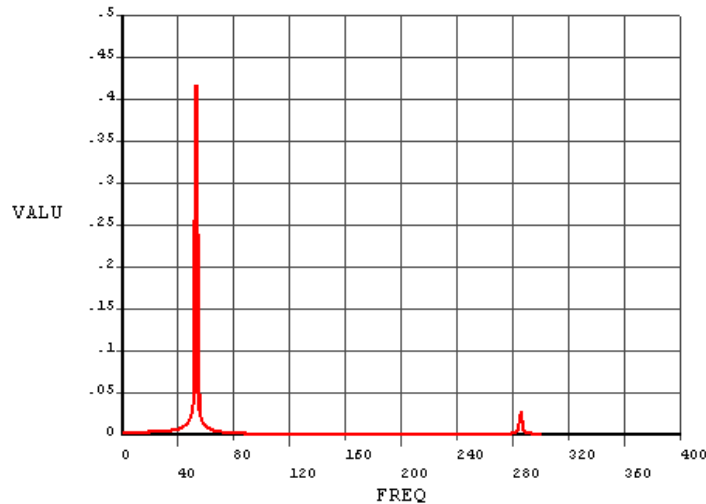

To get a better view of the response, view the log scale of UY. Select Utility Menu > PlotCtrl > Style > Graphs > Modify Axis

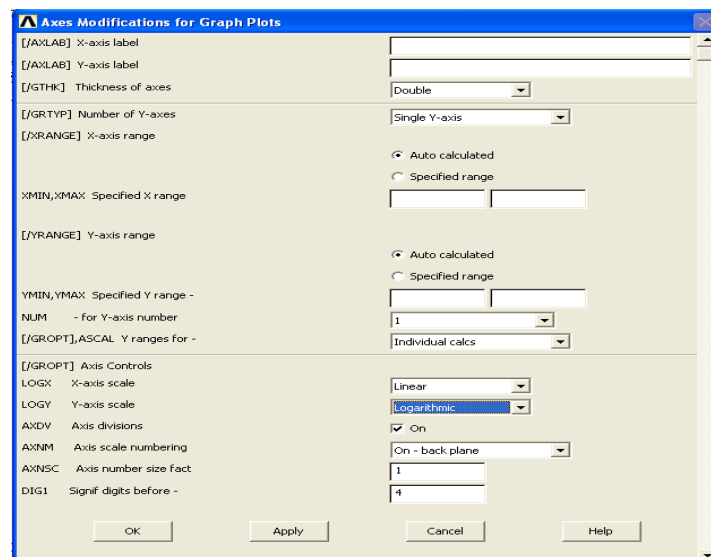

As in the above window, change the Y – axis scale (LOGY) to ‘**Logarithmic**’.

Select Utility Menu > Plot > Replot

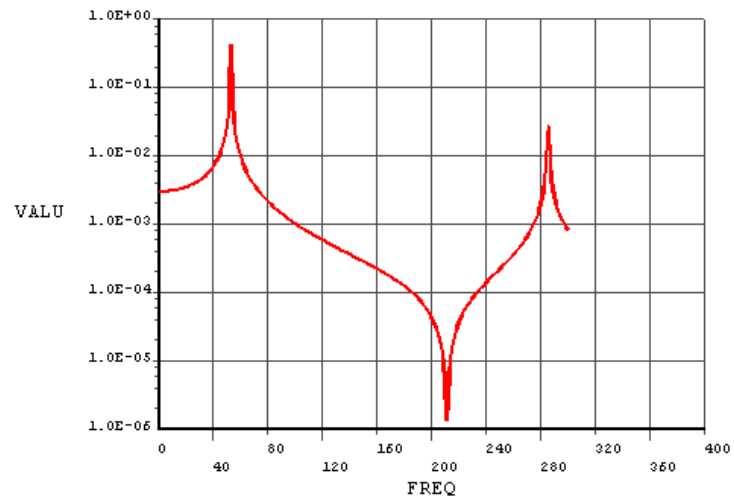

Chapter 12: THERMAL ANALYSIS

Thermal Analysis:

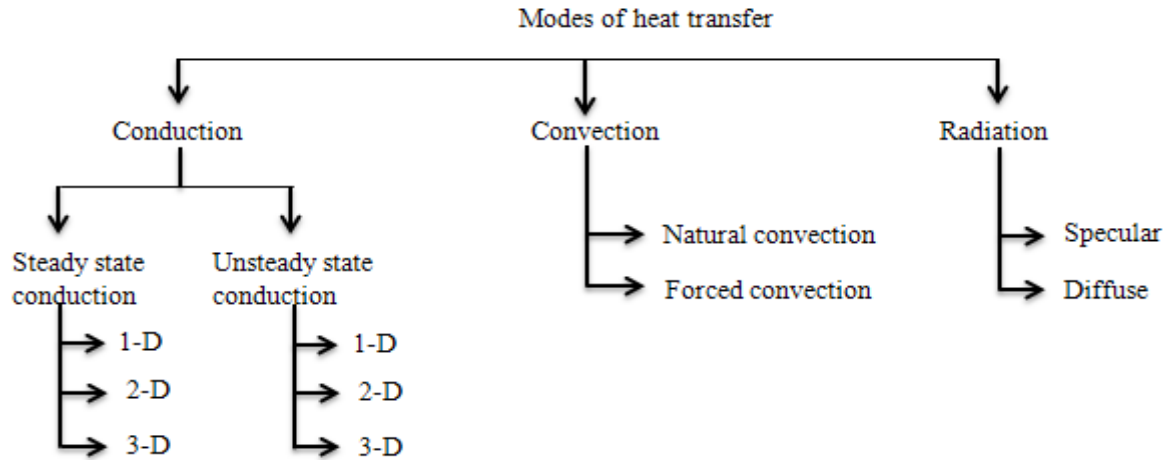

Practical application: Engine, radiator, exhaust system , heat exchangers, power plants, satellite,design.etc...

Commonly used software's: Ansys, MD Nastran, Abaqus, I-deas, NX etc....

HEAT TRANSFER:

General Steps to be followed while solving a problem by using FEM:

1. Discretize and select the element type
2. Choose a temperature function.
3. Define the temperature gradient / temperature and heat flux/ temperature gradient relationships.
4. Derive the element conduction matrix and equations by using either variational approach or by using Galerkin's approach
5. Assemble the element equations to obtain the global equations and introduce boundary conditions.
6. Solve for the nodal temperatures
7. Solve for the element temperature gradients and heat fluxes.

HEAT TRANSFER ONE DIMENSIONAL FINITE ELEMENT FORMULATION USING VARIATIONAL APPROACH STEPS TO BE FOLLOWED:

Step 1. Select element type.

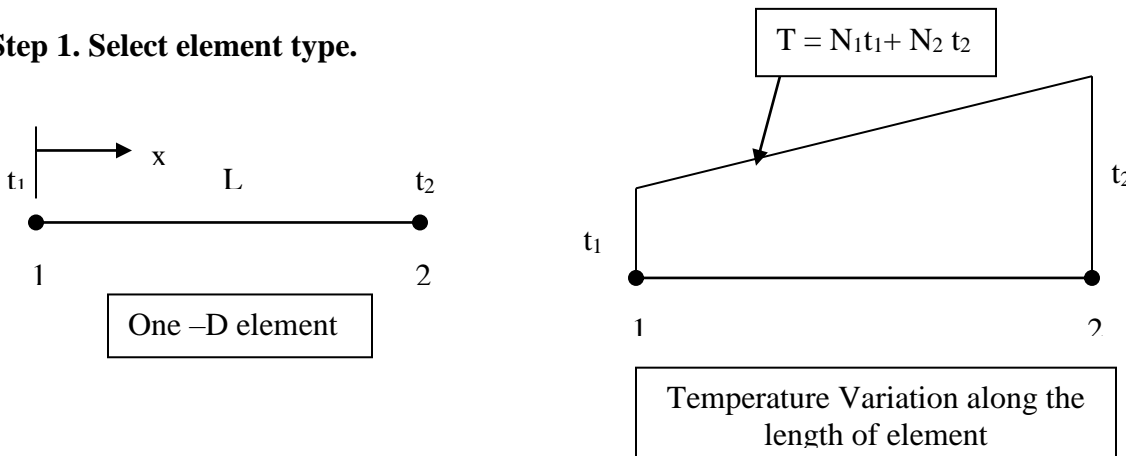

Step 2. Choose a temperature function.

We choose, $T(x) = N_1 t_1 + N_2 t_2$ ----- (1)

Where,

- t_1 is the temperature at node 1
- t_2 is the temperature at node 2

N_1 & N_2 are shape functions given by, $N_1 = 1 - \frac{x}{L}$, $N_2 = \frac{x}{L}$ ----- (2)

In matrix form, we write,

$$[N] = \begin{bmatrix} 1 - \frac{x}{L} & \frac{x}{L} \end{bmatrix} \text{ and } \{t\} = \begin{Bmatrix} t_1 \\ t_2 \end{Bmatrix} \text{ ----- (3)}$$

Therefore one can express T as $\{T\} = [N]\{t\}$ ----- (4)

Step 3. Define the temperature gradient / temperature and heat flux/ temperature gradient relationships.

The temperature gradient matrix $\{g\}$, similar to strain matrix $\{\epsilon\}$ used in structural analysis is given

$$\text{by, } \{g\} = \left\{ \frac{dT}{dx} \right\} = [B]\{t\} \text{ ----- (5)}$$

Where, $[B]$ is obtained by substituting equation (1) for $T(x)$ into equation (5) and differentiating w.r.t x , that is,

$$[B] = \begin{bmatrix} \frac{dN_1}{dx} & \frac{dN_2}{dx} \end{bmatrix} = \begin{bmatrix} -\frac{1}{L} & \frac{1}{L} \end{bmatrix} \text{ ----- (6)}$$

The heat flux /temperature gradient relationship is given by,

$$q_x = -[D]\{g\} \text{ ----- (7)}$$

Where the material property matrix is now given by,

$$[D] = [K_{xx}] \text{ ----- (8)}$$

Step 4. Derive the element conduction matrix and equations.

Consider the following equations.

$$K_{xx} \frac{d^2T}{dx^2} + Q = 0 \text{ ----- (I)}$$

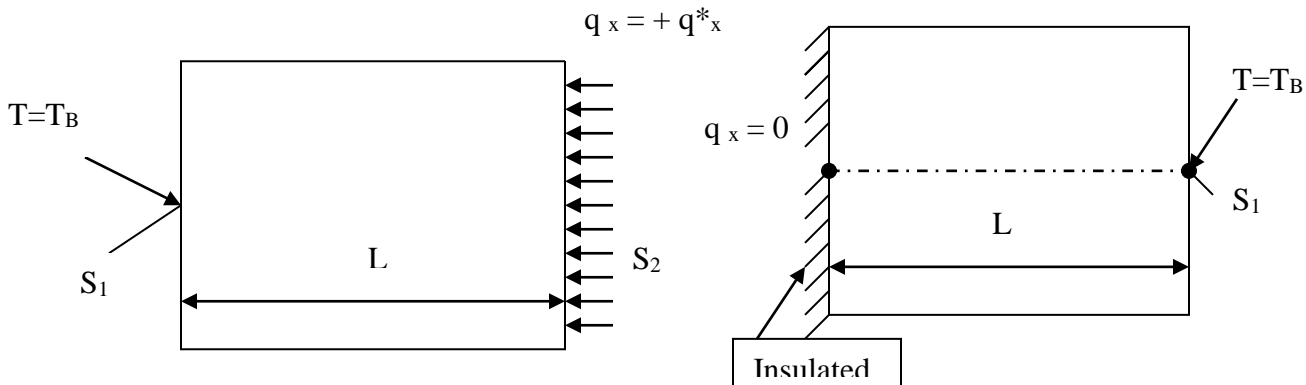

With $T = T_B$ on surface S_1 , $q_x^* = -K_{xx} \frac{dT}{dx} = \text{Constant}$ on S_2

Where, Q is heat generated / unit volume and q_x^* is the heat flow / unit area

q_x^* is positive when heat is flowing into body

is negative when heat is flowing out of the body

is Zero on an insulated boundary.

$$\text{And } \frac{\partial}{\partial x} \left(K_{xx} \frac{\partial T}{\partial x} \right) + Q = \rho C \frac{\partial T}{\partial t} + \frac{hP}{A} (T - T_\infty) \text{-----(II)}$$

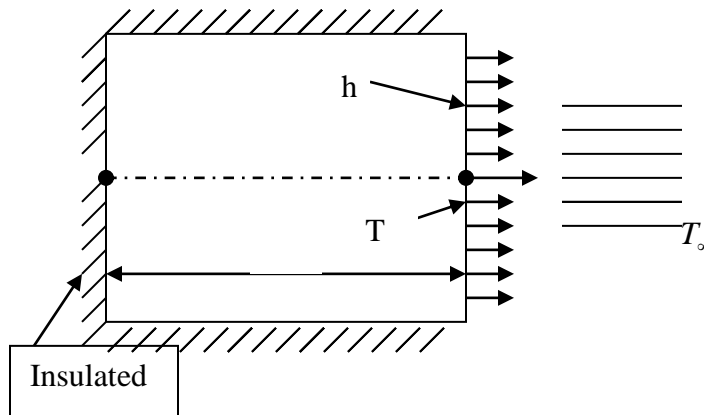

With the first boundary condition of above equation and /or second boundary condition and /or loss of heat by convection from the ends of 1-D body.

We have,

$$-K_{xx} \frac{dT}{dx} = h(T - T_\infty) \text{ on surface } S_3$$

Above equations can be shown to be derivable by the minimization of the following functional (analogous to the potential energy functional π)

$$\Pi_h = U + \Omega_Q + \Omega_q + \Omega_h \text{----- III}$$

Where,

$$U = \frac{1}{2} \int_v \left[K_{xx} \left(\frac{dT}{dx} \right)^2 \right] dV, \quad \Omega_Q = - \int_v QT dV, \quad \Omega_q = - \int_{S_2} q^* T dS \quad \text{and}$$

$$\Omega_h = \frac{1}{2} \int_{S_3} h(T - T_\infty)^2 dS \text{-----(9)}$$

(q^* and h on the same surface cannot be specified simultaneously because they cannot occur on the same surface)

Therefore,

$$\begin{aligned}\Pi_h &= U + \Omega_Q + \Omega_q + \Omega_h \\ &= \frac{1}{2} \int_V \left[\mathbf{K}_{xx} \left(\frac{dT}{dx} \right)^2 \right] dV - \int_V Q T dV - \int_{S_2} \mathbf{q}^* T dS + \frac{1}{2} \int_{S_3} h (T - T_\infty)^2 dS \text{ -----(10)}\end{aligned}$$

Consider the first term of equation (10),

$$\frac{1}{2} \int_V \left[\mathbf{K}_{xx} \left(\frac{dT}{dx} \right)^2 \right] dV = \frac{1}{2} \int_V \{ \mathbf{g} \}^T [D] \{ \mathbf{g} \} dV \text{ -----(11)}$$

Consider the second term of equation (10),

$$\int_V Q T dV = \int_V \{ \mathbf{t} \}^T [N]^T Q dV \text{ -----(12)}$$

Third term of equation (10) gives,

$$\int_{S_2} \mathbf{q}^* T dS = \int_{S_2} \{ \mathbf{t} \}^T [N]^T \mathbf{q}^* dS \text{ -----(13)}$$

Fourth term gives,

$$\frac{1}{2} \int_{S_3} h (T - T_\infty)^2 dS = \frac{1}{2} \int_{S_3} h \{ \mathbf{t} \}^T [N]^T - T_\infty \}^2 dS \text{ -----(14)}$$

Substituting equations (11),(12),(13) and (14) in equation (10) we obtain

$$\begin{aligned}\Pi_h &= \frac{1}{2} \int_V \{ \mathbf{g} \}^T [D] \{ \mathbf{g} \} dV - \int_V \{ \mathbf{t} \}^T [N]^T Q dV \\ &\quad - \int_{S_2} \{ \mathbf{t} \}^T [N]^T \mathbf{q}^* dS + \frac{1}{2} \int_{S_3} h \{ \mathbf{t} \}^T [N]^T - T_\infty \}^2 dS \\ &= \frac{1}{2} \{ \mathbf{t} \}^T \int_V [B]^T [D] [B] dV \{ \mathbf{t} \} - \{ \mathbf{t} \}^T \int_V [N]^T Q dV - \{ \mathbf{t} \}^T \int_{S_2} [N]^T \mathbf{q}^* dS \\ &\quad + \frac{1}{2} \int_{S_3} h \{ \mathbf{t} \}^T [N]^T [N] \{ \mathbf{t} \} - \left(\{ \mathbf{t} \}^T [N]^T + [N] \{ \mathbf{t} \} \right) T_\infty + T_\infty^2 \} dS \text{ -----(15)}\end{aligned}$$

In equation (15), the

minimization is most easily accomplished by explicitly writing the surface integral S_3 with $\{ \mathbf{t} \}$, left inside the integral as shown.

On minimizing equation (15) w.r.t. $\{ \mathbf{t} \}$, we get

$$\begin{aligned}\frac{\partial \Pi_h}{\partial \{ \mathbf{t} \}} &= \int_V [B]^T [D] [B] dV \{ \mathbf{t} \} - \int_V [N]^T Q dV - \int_{S_2} [N]^T \mathbf{q}^* dS \\ &\quad + \int_{S_3} h [N]^T [N] dS \{ \mathbf{t} \} - \int_{S_3} [N]^T h T_\infty dS = 0 \text{ -----(16)}\end{aligned}$$

On simplifying,

$$\left[\int_V [B]^T [D] [B] dV + \int_{S_3} h [N]^T [N] dS \right] \{ \mathbf{t} \} = \{ \mathbf{f}_Q \} + \{ \mathbf{f}_q \} + \{ \mathbf{f}_h \} \text{ -----(17)}$$

Where the force matrices have been defined by,

$$\{ \mathbf{f}_Q \} = \int_V [N]^T Q dV, \{ \mathbf{f}_q \} = \int_{S_2} [N]^T \mathbf{q}^* dS, \{ \mathbf{f}_h \} = \int_{S_3} [N]^T h T_\infty dS$$

Equation (17) can be written in the form

$$\{ \mathbf{f} \} = [K] \{ \mathbf{t} \} \text{ -----(18)}$$

$$\text{Where } [K] = \int_V [B]^T [D][B] dV + \int_{S_3} h [N]^T [N] dS = [K_c] + [K_h] \text{----- (19)}$$

The first term of the equation (19) represent **conduction part of K** and second term of the equation (19) represent **convection part of K**.

$$\text{Now consider the conduction part, } [K_c] = \int_V [B]^T [D][B] dV \text{----- (20)}$$

Substituting for B, D and dV in the equation (20) we get,

$$\int_0^L \left\{ \begin{matrix} -\frac{1}{L} \\ \frac{1}{L} \end{matrix} \right\} [K_{xx}] \left[\begin{matrix} -\frac{1}{L} & \frac{1}{L} \end{matrix} \right] A dx = \frac{AK_{xx}}{L^2} \int_0^L \left[\begin{matrix} 1 & -1 \\ -1 & 1 \end{matrix} \right] dx, \text{ i.e. } [K_c] = \frac{AK_{xx}}{L} \left[\begin{matrix} 1 & -1 \\ -1 & 1 \end{matrix} \right] \text{----- (21)}$$

$$\text{The convection part } [K_h] \text{ is } [K_h] = \int_{S_3} h [N]^T [N] dS = hP \int_0^L \left\{ \begin{matrix} 1 - \frac{x}{L} \\ \frac{x}{L} \end{matrix} \right\} \left[\begin{matrix} 1 - \frac{x}{L} & \frac{x}{L} \end{matrix} \right] dx = \frac{hPL}{6} \left[\begin{matrix} 2 & 1 \\ 1 & 2 \end{matrix} \right] \text{----- (22)}$$

Where dS = P dx

$$\text{Therefore } [K] = \frac{AK_{xx}}{L} \left[\begin{matrix} 1 & -1 \\ -1 & 1 \end{matrix} \right] + \frac{hPL}{6} \left[\begin{matrix} 2 & 1 \\ 1 & 2 \end{matrix} \right] \text{----- (23)}$$

The force matrix terms will be,

$$\{f_Q\} = \int_V [N]^T Q dV = QA \int_0^L \left\{ \begin{matrix} 1 - \frac{x}{L} \\ \frac{x}{L} \end{matrix} \right\} dx = \frac{QAL}{2} \left\{ \begin{matrix} 1 \\ 1 \end{matrix} \right\},$$

$$\{f_q\} = \int_{S_2} [N]^T q * dS = q * P \int_0^L \left\{ \begin{matrix} 1 - \frac{x}{L} \\ \frac{x}{L} \end{matrix} \right\} dx = \frac{q * PL}{2} \left\{ \begin{matrix} 1 \\ 1 \end{matrix} \right\}$$

$$\{f_h\} = \int_{S_3} [N]^T h T_\infty dS = \frac{h T_\infty PL}{2} \left\{ \begin{matrix} 1 \\ 1 \end{matrix} \right\}$$

Therefore adding we get,

$$\begin{aligned} \{f\} &= \{f_Q\} + \{f_q\} + \{f_h\} = \frac{QAL}{2} \left\{ \begin{matrix} 1 \\ 1 \end{matrix} \right\} + \frac{q * PL}{2} \left\{ \begin{matrix} 1 \\ 1 \end{matrix} \right\} + \frac{h T_\infty PL}{2} \left\{ \begin{matrix} 1 \\ 1 \end{matrix} \right\} \\ &= \frac{QAL + q * PL + h T_\infty PL}{2} \left\{ \begin{matrix} 1 \\ 1 \end{matrix} \right\} \text{----- (24)} \end{aligned}$$

Consider the convection force from the end of the element as shown.



The additional convection term contribution to the stiffness matrix is given by,

$$[K_h]_{end} = \int_{S_{end}} h [N]^T [N] dS \text{ ----- (25)}$$

$N_1 = 0$ and $N_2 = 1$ at right end and

$$[K_h]_{end} = \int_{S_{end}} h \begin{Bmatrix} 0 \\ 1 \end{Bmatrix} [0 \ 1] dS = hA \begin{bmatrix} 0 & 0 \\ 0 & 1 \end{bmatrix} \text{ ----- (26)}$$

The convection force from the free end of the element is obtained from the application of equation of $\{f_h\}$ with the shape function now evaluated at the right end and with S_3 (the surface over which convection occurs) now equal to the c/s area A of the rod.

$$\{f_h\}_{end} = hT_\infty A \begin{Bmatrix} N_1(x=L) \\ N_2(x=L) \end{Bmatrix} = hT_\infty A \begin{Bmatrix} 0 \\ 1 \end{Bmatrix} \text{ ----- (26)}$$

Step 5. Assemble the element equations to obtain the global equations and introduce boundary conditions.

The global structure conduction matrix is

$$[K] = \sum_{e=1}^n [K^e]$$

The global force matrix is

$$\{F\} = \sum_{e=1}^n \{f^e\}$$

and global equations are

$$\{F\} = [K]\{t\}$$

Step 6. Solve for the nodal temperatures

Step 7. Solve for the element temperature gradients and heat fluxes.

ONE DIMENSIONAL FINITE ELEMENT FORMULATION USING GALERKIN'S APPROACH

Equation representing one dimensional formulation of conduction with convection is given by,

$$k_x \frac{d^2T}{dx^2} + Q = \frac{hP}{A} (T - T_\infty) \text{ ----- (1)}$$

To derive the finite element equations, a two-noded linear element with the temperature function $T(x) = N_1 t_1 + N_2 t_2$ ----- (2) is considered

The residual equations for the equation (I) are expressed as,

$$\int_{x_1}^{x_2} \left[k_x \frac{d^2 T}{dx^2} + Q - \frac{hP}{A} (T - T_\infty) \right] N_i A dx = 0 \quad \text{----- (3) Where } i = 1, 2$$

Or

$$A \int_{x_1}^{x_2} k_x \frac{d^2 T}{dx^2} N_i dx - hP \int_{x_1}^{x_2} T N_i dx + A \int_{x_1}^{x_2} Q N_i dx + hP T_\infty \int_{x_1}^{x_2} N_i dx = 0 \quad \text{----- (4) Where } i = 1, 2$$

Integrating the first term of equation (4) by parts and rearranging, we get

$$k_x A \int_{x_1}^{x_2} \frac{dN_i}{dx} \frac{dT}{dx} dx + hP \int_{x_1}^{x_2} T N_i dx = A \int_{x_1}^{x_2} Q N_i dx + hP T_\infty \int_{x_1}^{x_2} N_i dx + K_x A N_i \frac{dT}{dx} \Big|_{x_2} \quad \text{--- (5)}$$

Where $i = 1, 2$

Substituting for T from equation (2) we obtain,

$$\begin{aligned} & k_x A \int_{x_1}^{x_2} \frac{dN_i}{dx} \left(\frac{dN_1}{dx} t_1 + \frac{dN_2}{dx} t_2 \right) dx + hP \int_{x_1}^{x_2} N_i [N_1 t_1 + N_2 t_2] dx \\ & = A \int_{x_1}^{x_2} Q N_i dx + hP T_\infty \int_{x_1}^{x_2} N_i dx + K_x A N_i \frac{dT}{dx} \Big|_{x_2} \quad \text{--- (6)} \end{aligned}$$

The two equations represented by the equation (6) are conveniently combined into a matrix form by rewriting equation (1) as,

$$T(x) = [N_1 \quad N_2] \begin{Bmatrix} t_1 \\ t_2 \end{Bmatrix} = [N] \{t\} \quad \text{----- (7)}$$

and substituting to obtain,

$$\begin{aligned} & k_x A \int_{x_1}^{x_2} \left[\frac{dN}{dx} \right]^T \left[\frac{dN}{dx} \right] \{t\} dx + hP \int_{x_1}^{x_2} [N]^T [N] \{t\} dx \\ & = A \int_{x_1}^{x_2} Q [N]^T dx + hP T_\infty \int_{x_1}^{x_2} [N]^T dx + K_x A [N]^T \frac{dT}{dx} \Big|_{x_2} \quad \text{--- (8)} \end{aligned}$$

The above equation now can be written in the desired finite element form as,

$$[k^e] \{t\} = \{f_Q^e\} + \{f_q^e\} + \{f_h^e\} \quad \text{----- (9)}$$

Where $[k^e]$ is the conductance matrix defined as

$$[k^e] = k_x A \int_{x_1}^{x_2} \left[\frac{dN}{dx} \right]^T \left[\frac{dN}{dx} \right] dx + hP \int_{x_1}^{x_2} [N]^T [N] dx \quad \text{---(10)}$$

First term of the above equation represents the conductance part where as the second term convection part of the conduction matrix.

Let $x_1 = 0$ and $x_2 = L$, then,

$$N_1 \ \& \ N_2 \quad \text{are shape functions given by, } N_1 = 1 - \frac{x}{L}, \quad N_2 = \frac{x}{L} \quad \text{---(11)}$$

If one substitute for N_1 & N_2 in equation (10) and solve then $[k^e]$ is given by,

$$[k^e] = \frac{Ak_x}{L} \begin{bmatrix} 1 & -1 \\ -1 & 1 \end{bmatrix} + \frac{hPL}{6} \begin{bmatrix} 2 & 1 \\ 1 & 2 \end{bmatrix} = [k_c^e] + [k_h^e] \quad \text{---(12)}$$

The forcing function vectors on the right hand side of the equation (8) are given by

$$\{f_Q^e\} = A \begin{Bmatrix} \int_0^L QN_1 dx \\ \int_0^L QN_2 dx \end{Bmatrix} = \frac{QAL}{2} \begin{Bmatrix} 1 \\ 1 \end{Bmatrix}$$

$$\{f_q^e\} = k_x A \begin{Bmatrix} -\left. \frac{dT}{dx} \right|_0 \\ \left. \frac{dT}{dx} \right|_L \end{Bmatrix} = A \begin{Bmatrix} q_{x=0} \\ -q_{x=L} \end{Bmatrix} = A \begin{Bmatrix} q_1 \\ -q_2 \end{Bmatrix} \quad \text{Where } q_1 \text{ and } q_2 \text{ are the boundary fluxes at}$$

nodes 1 and 2 respectively.

$$\{f_h^e\} = hT_\infty P \begin{Bmatrix} \int_0^L N_1 dx \\ \int_0^L N_2 dx \end{Bmatrix} = \frac{hT_\infty PL}{2} \begin{Bmatrix} 1 \\ 1 \end{Bmatrix} \quad \text{---(13)}$$

LINK33: 3-D Conduction33 Bar

LINK33 is a uniaxial element with the ability to conduct heat between its nodes. The element has a single degree of freedom, temperature, at each node point. The conducting bar is applicable to a steady-state or transient thermal analysis. If the model containing the conducting bar element is also to be analyzed structurally, the bar element should be replaced by an equivalent structural element. The conducting bar is applicable to a 3-D (plane or axisymmetric), steady-state or transient thermal analysis.

LINK33 Input Data

The element is defined by two nodes, a cross-sectional area, and the material properties. Specific heat and density are ignored for steady-state solutions. The thermal conductivity is in the element longitudinal direction.

Element loads are described in [Nodal Loading](#). Heat generation rates may be input as element body loads at the nodes. The node J heat generation rate HG(J) defaults to the node I heat generation rate HG(I).

Element loads are described in [Node and Element Loads](#). Heat generation rates may be input as element body loads at the nodes. The node J heat generation rate HG(J) defaults to the node I heat generation rate HG(I).

LINK33 Input Summary

Nodes I, J
Degrees of Freedom TEMP
Real Constants AREA - Cross-sectional area
Material Properties KXX, DENS, C, ENTH
Surface Loads None
Body Loads Heat Generation -- HG(I), HG(J)

LINK33 Output Data

The solution output associated with the element is in two forms:

- Nodal temperatures included in the overall nodal solution
- Additional element output as shown in [Table: "LINK33 Element Output Definitions"](#)

The Element Output Definitions table uses the following notation:

A colon (:) in the Name column indicates the item can be accessed by the Component Name method [[ETABLE](#), [ESOL](#)]. The O column indicates the availability of the items in the file Jobname.OUT. The R column indicates the availability of the items in the results file.

In either the O or R columns, Y indicates that the item is *always* available, a number refers to a table footnote that describes when the item is *conditionally* available, and a - indicates that the item is *not* available.

Table LINK33 Element Output Definitions

Name	Definition	O	R
EL	Element Number	Y	Y
NODES	Nodes - I, J	Y	Y
MAT	Material	Y	Y
VOLU:	Volume	Y	Y
XC, YC	Location where results are reported	Y	<u>1</u>
LENGTH	Length	Y	Y
AREA	Input area	Y	Y
TEMP(I, J)	Temperatures - I, J	Y	Y
HEAT RATE	Heat flow rate from node I to node J	Y	Y
THERMAL FLUX	Thermal flux (heat flow rate/cross-sectional area)	Y	Y

Name output quantity as defined in the [Table: "LINK33 Element Output Definitions"](#)

Item

predetermined Item label for [ETABLE](#) command

E sequence number for single-valued or constant element data

Table LINK33 Item and Sequence Numbers

Output Quantity Name	ETABLE and ESOL Command Input	
	Item	E
HEAT RATE	SMISC	1
TEMPI	SMISC	2
TEMPJ	SMISC	3
THERMAL FLUX	SMISC	4
LENGTH	NMISC	1
AREA	NMISC	2

LINK34: Convection34**LINK34 Element Description**

LINK34 is a uniaxial element with the ability to convect heat between its nodes. The element has a single degree of freedom, temperature, at each node point. The convection element is applicable to a 2-D (plane or axisymmetric) or 3-D, steady-state or transient thermal analysis.

If the model containing the convection element is also to be analyzed structurally, the convection element should be replaced by an equivalent (or null) structural element.

LINK34 Input Data

The geometry and node locations for this convection element are shown in [Figure "LINK34 Geometry"](#). The element is defined by two nodes, a convection surface area, two empirical terms, and a film coefficient. In an axisymmetric analysis the convection area must be expressed on a full 360° basis. The empirical terms n (input as EN) and CC determine the form of the convection equation in conjunction with KEYOPT(3). The convection function is defined as follows:

$q = h_f * A * E * (T(I) - T(J))$ where:

q = heat flow rate (Heat/Time)

h_f = film coefficient (Heat/Length²*Time*Deg)

A = area (Length²)

T = temperature (this substep) (Deg)

E = empirical convection term = $F * T_p(I) - T_p(J)^n + CC/h_f$

T_p = temperature (previous substep) (Deg)

n = empirical coefficient (EN)

CC = input constant

LINK34 Input Summary

Nodes I, J

Degrees of Freedom TEMP

Real Constants

AREA - Convection surface area

EN - Empirical coefficient

CC - Input constant

Material Properties HF

Surface Loads Convections --

Body Loads Heat Generation -- HG(I), HG(J)

LINK34 Output Data

The solution output associated with the element is in two forms:

- Nodal temperatures included in the overall nodal solution
- Additional element output as shown in [Table 34.1: "LINK34 Element Output Definitions"](#)

The heat flow rate is in units of Heat/Time and is positive from node I to node J. In an axisymmetric analysis, the heat flow is on a full 360° basis. A general description of solution output is given in [Solution Output](#). See the [Basic Analysis Guide](#) for ways to view results.

The Element Output Definitions table uses the following notation:

A colon (:) in the Name column indicates the item can be accessed by the Component Name method [[ETABLE](#), [ESOL](#)]. The O column indicates the availability of the items in the file Jobname.OUT. The R column indicates the availability of the items in the results file.

In either the O or R columns, Y indicates that the item is *always* available, a number refers to a table footnote that describes when the item is *conditionally* available, and a - indicates that the item is *not* available.

Table 34.1 LINK34 Element Output Definitions

Name	Definition	O	R
EL	Element Number	Y	Y
NODES	Nodes - I, J	Y	Y
XC, YC	Location where results are reported	Y	1
H	Film coefficient (includes empirical term)	Y	Y
AREA	Input area	Y	Y
TEMP	Temperature at node I and node J	Y	Y
HEAT RATE	Heat flow rate from node I to node J	Y	Y

Table LINK34 Item and Sequence Numbers

Output Quantity Name	ETABLE and ESOL Command Input			
	Item	E	I	J
HEAT RATE	SMISC	1	-	-
TEMP	SMISC	-	2	3
H	NMISC	1	-	-
AREA	NMISC	2	-	-

LINK34 Assumptions and Restrictions

- If $T_p(I) = T_p(J)$ and n are nonzero, the first term of E is defined to be zero.
- Since all unspecified nodal temperatures are initially set to the uniform temperature, a nonzero value of n may result in no heat flowing through the element in the first substep of a thermal solution.
- Nodes may or may not be coincident.
- The element is nonlinear if n is nonzero or $KEYOPT(3) = 3$. However, the solver always assumes the element is nonlinear and, therefore, always performs an iterative solution. (Only 2 iterations are performed if the element is linear.)

Problem 66: For the composite wall idealized by the 1-D model shown in figure below, determine the interface temperatures. For element 1, let $K_1 = 5 \text{ W / m}^\circ\text{C}$, for element 2, $K_2 = 10 \text{ W / m}^\circ\text{C}$ and for element 3, $K_3 = 15 \text{ W / m}^\circ\text{C}$. The left end has a constant temperature of 200°C and the right end has a constant temperature of 600°C .

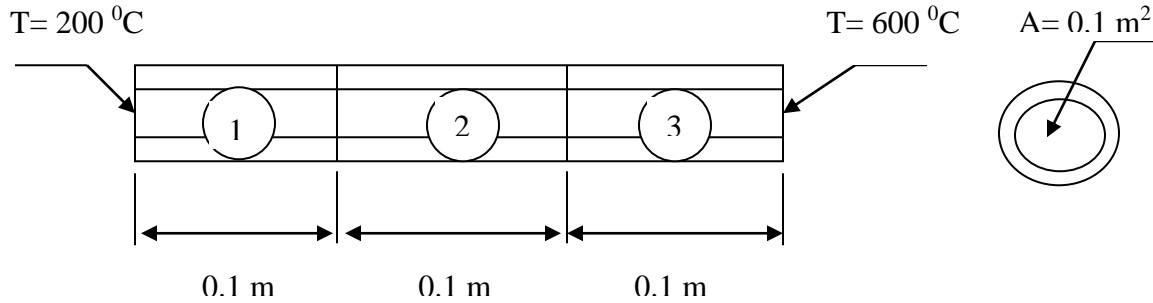

Solution:

$t_1 = 200^\circ\text{C}$	$t_4 = 200^\circ\text{C}$	$A = 0.1 \text{ m}^2$
$K_1 = 5 \text{ W / m}^\circ\text{C}$	$K_2 = 10 \text{ W / m}^\circ\text{C}$	$K_3 = 15 \text{ W / m}^\circ\text{C}$

Given:

Finite Element model:

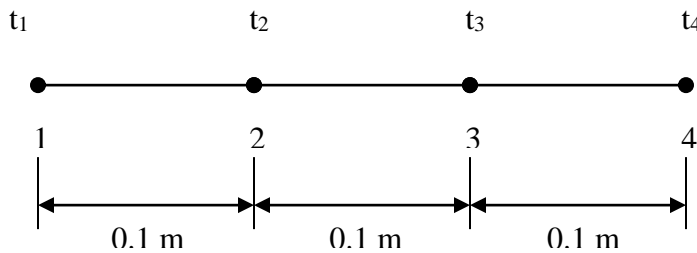

Step 1- Ansys Utility Menu

File -Clear and start new -Do not read file -ok

File -Change job name -Enter new job name -probl -ok

File -Change title -Enter new title -yyy -ok

Step 2 -Ansys Main Menu -Preferences

Select -THERMAL -ok

Step 3 -Preprocessor

Element Type -Add/Edit/Delete -Add- LINK>3D CONDUCTION -33- ok -close

Real constants - Add/Edit/Delete-Add-type 1-link 33- real constant set no 1 – cross sectional area – enter -0.1-ok-close

Material properties – Material models – material model number 1-thermal – conductivity – isotropic - conductivity for material - thermal conductivity (K_{xx}) –5 -ok- material –new model – define material ID -2-ok- thermal – conductivity –isotropic - conductivity for material - thermal conductivity (K_{xx}) –10 –ok- material –new model – define material ID -3-ok- thermal – conductivity –isotropic - conductivity for material - thermal conductivity (K_{xx}) –15 –ok-close

Preprocessor-Modeling -Create -Nodes -in active CS -x,y,z location in CS-0,0,0 (x,y value w.r.t first node)- apply (first node is created) - 0.1,0,0 -apply (second node is created) -0.2,0,0 –apply (third node is created)- 0.3,0,0 -apply (fourth node is created) -ok

Create –elements-element attributes-select material number-1-real constant set number -1-Auto numbered – thru nodes – pick 1, 2 (element 1 is created)-ok - element attributes-select material

number-2-real constant set number -1-Auto numbered – thru nodes – pick 2, 3 (element 2 is created)-ok- element attributes-select material number-3-real constant set number -1-Auto numbered – thru nodes – pick 3, 4 (element 3 is created)-ok

Loads - Define Loads - Apply –thermal –select temperature –on nodes-pick node 1-apply-select –TEMP- value -200-apply- pick node 2-apply-select –TEMP- value -600-ok

Step 6 -Ansys Main Menu –Solution: Solve -solve current LS -ok (;If everything is ok, -solution is done is displayed) –close

Step 7 -Ansys Main Menu -General. Post Processor. Plot results- Contour Plots - Nodal solution –DOF solution.-temp -ok (Temp distribution plot) List results -nodal solution -Dof solution -temp -ok (Temperature at all the nodes will be displayed) Plotctrls- Animate – Deformed results – Dof solution – Temperature – ok (for animation)

Results:

```

PRNSOL Command
File
PRINT TEMP NODAL SOLUTION PER NODE
***** POST1 NODAL DEGREE OF FREEDOM LISTING *****
LOAD STEP=      1  SUBSTEP=      1
TIME=      1.0000  LOAD CASE=      0
      NODE      TEMP
      1      200.00
      2      418.18
      3      527.27
      4      600.00
MAXIMUM ABSOLUTE VALUES
NODE      4
VALUE      600.00
    
```

Manual solution for same Problem

For the composite wall idealized by the 1-D model shown in figure below, determine the interface temperatures. For element 1, let $K_1 = 5 \text{ W / m } ^\circ\text{C}$, for element 2, $K_2 = 10 \text{ W / m } ^\circ\text{C}$ and for element 3, $K_3 = 15 \text{ W / m } ^\circ\text{C}$. The left end has a constant temperature of $200 \text{ } ^\circ\text{C}$ and the right end has a constant temperature of $600 \text{ } ^\circ\text{C}$.

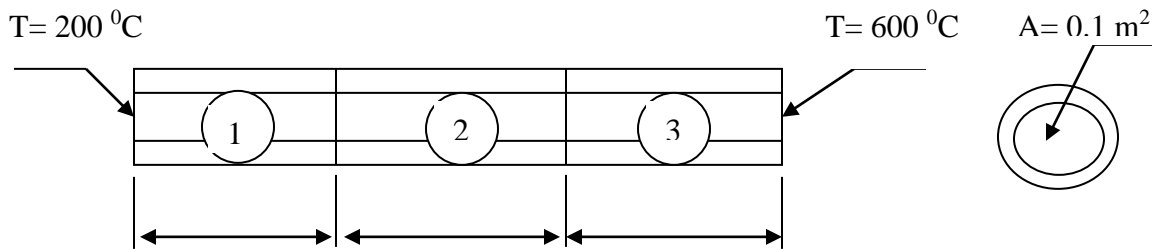

Solution:	0.1 m	0.1 m	0.1 m	$A = 0.1 \text{ m}^2$
Given:	$T_1 = 200 \text{ } ^\circ\text{C}$	$T_4 = 600 \text{ } ^\circ\text{C}$		$K_3 = 15 \text{ W / m } ^\circ\text{C}$
	$K_1 = 5 \text{ W / m } ^\circ\text{C}$	$K_2 = 10 \text{ W / m } ^\circ\text{C}$		

Finite Element model:

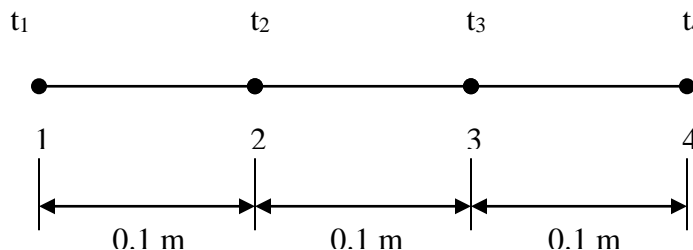

Element conduction matrices are,

$$[k^1] = \frac{A_1 K_1}{L_1} \begin{bmatrix} 1 & -1 \\ -1 & 1 \end{bmatrix} = \frac{0.1 \times 5}{0.1} \begin{bmatrix} 1 & -1 \\ -1 & 1 \end{bmatrix} = \begin{bmatrix} 5 & -5 \\ -5 & 5 \end{bmatrix} \begin{matrix} 1R \\ 2R \end{matrix}$$

$$[k^2] = \frac{A_2 K_2}{L_2} \begin{bmatrix} 1 & -1 \\ -1 & 1 \end{bmatrix} = \frac{0.1 \times 10}{0.1} \begin{bmatrix} 1 & -1 \\ -1 & 1 \end{bmatrix} = \begin{bmatrix} 10 & -10 \\ -10 & 10 \end{bmatrix} \begin{matrix} 2R \\ 3R \end{matrix}$$

$$[k^3] = \frac{A_3 K_3}{L_3} \begin{bmatrix} 1 & -1 \\ -1 & 1 \end{bmatrix} = \frac{0.1 \times 15}{0.1} \begin{bmatrix} 1 & -1 \\ -1 & 1 \end{bmatrix} = \begin{bmatrix} 15 & -15 \\ -15 & 15 \end{bmatrix} \begin{matrix} 3R \\ 4R \end{matrix}$$

And the global structure conduction matrix is,

$$[K] = \begin{bmatrix} 1C & 2C & 3C & 4C \\ 5 & -5 & 0 & 0 \\ -5 & 5+10 & -10 & 0 \\ 0 & -10 & 10+15 & -15 \\ 0 & 0 & -15 & 15 \end{bmatrix} \begin{matrix} 1R \\ 2R \\ 3R \\ 4R \end{matrix} = \begin{bmatrix} 1C & 2C & 3C & 4C \\ 5 & -5 & 0 & 0 \\ -5 & 15 & -10 & 0 \\ 0 & -10 & 25 & -15 \\ 0 & 0 & -15 & 15 \end{bmatrix} \begin{matrix} 1R \\ 2R \\ 3R \\ 4R \end{matrix}$$

Now the global equations are given by, $[K]\{t\} = \{F\}$ That is,

$$\begin{bmatrix} 5 & -5 & 0 & 0 \\ -5 & 15 & -10 & 0 \\ 0 & -10 & 25 & -15 \\ 0 & 0 & -15 & 15 \end{bmatrix} \begin{bmatrix} t_1 \\ t_2 \\ t_3 \\ t_4 \end{bmatrix} = \begin{bmatrix} F_1 \\ 0 \\ 0 \\ F_2 \end{bmatrix}$$

Since the values of t_1 and t_4 are specified, the equations are modified as follows.

$$\begin{bmatrix} 1 & 0 & 0 & 0 \\ 0 & 15 & -10 & 0 \\ 0 & -10 & 25 & 0 \\ 0 & 0 & 0 & 1 \end{bmatrix} \begin{bmatrix} t_1 \\ t_2 \\ t_3 \\ t_4 \end{bmatrix} = \begin{bmatrix} 200 \\ 1000 \\ 9000 \\ 600 \end{bmatrix}$$

We have now two equations and two unknowns since t_1 and t_4 are specified.

$$15t_2 - 10t_3 = 1000$$

$$-10t_2 + 25t_3 = 9000$$

On solving for t_2 and t_3 we get $t_3 = 527.3 \text{ } ^\circ\text{C}$ and $t_2 = 418.2 \text{ } ^\circ\text{C}$

Therefore, $\{t\}^T = [200 \text{ } ^\circ\text{C} \quad 418.2 \text{ } ^\circ\text{C} \quad 527.3 \text{ } ^\circ\text{C} \quad 600 \text{ } ^\circ\text{C}]$

From ANSYS it was

$$\{t\}^T = [200 \text{ } ^\circ\text{C} \quad 418.18 \text{ } ^\circ\text{C} \quad 527.27 \text{ } ^\circ\text{C} \quad 600 \text{ } ^\circ\text{C}]$$

Problem 67: A furnace wall is made of inside silica brick ($K=1.5 \text{ W /mK}$) and outside magnesia brick ($k=4.9\text{W/mK}$), each 10cm thick. The inner and outer surfaces are exposed to fluids at temperatures of 820°C and 110°C respectively. The contact resistance is $0.001\text{m}^2 \text{ K/W}$ the heat transfer co-efficient for inner and outer surfaces is equal to $35\text{W/m}^2 \text{ K}$. Find the heat flow through the wall per unit area per unit time and temperature distribution across the wall

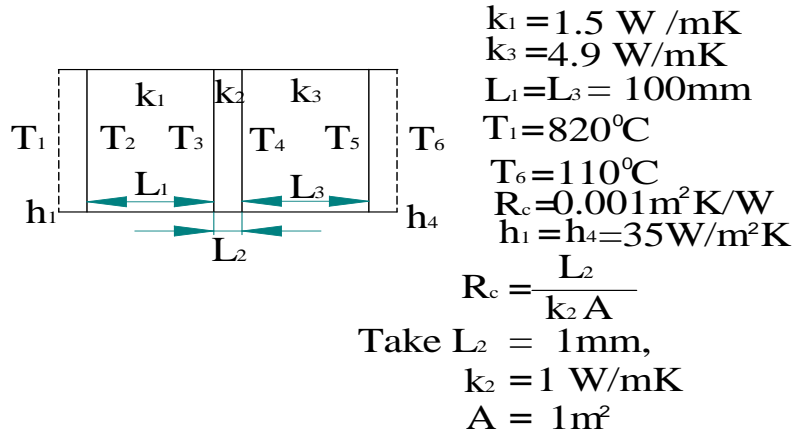

For FE model,

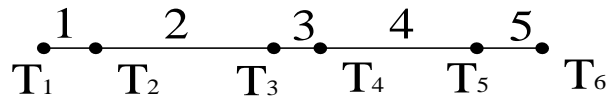

Element No.	Element Type
2, 3, 4	LINK 33
1, 5	LINK 34

Step 1- Ansys Utility Menu

File -Clear and start new -Do not read file -ok

File -Change job name -Enter new job name -problem60 -ok

File -Change title -Enter new title -yyy -ok

Step 2 -Ansys Main Menu -Preferences

Select -THERMAL -ok

Step 3 -Preprocessor

Element Type -Add/Edit/Delete -Add- LINK -3 D CONDUCTION -33- apply -CONVECTION 34 - ok - close

Real constants - Add/Edit/Delete-Add-select-type 1-link 33- real constant set no 1 - cross sectional area -enter -1-ok-close - Add-Select- Type 2 Link 34 - Real Constant Set No. 2 - Cross Sectional area - enter - 1 - ok - close.

Material properties - Material models - material model number 1-thermal - conductivity - isotropic - conductivity for material - thermal conductivity (K_{xx}) -1.5 -ok- material -new model - define material ID -2-ok- thermal - conductivity -isotropic - conductivity for material - thermal conductivity (K_{xx}) -1 -ok- material -new model - define material ID -3-ok- thermal - conductivity - isotropic - conductivity for material - thermal conductivity (K_{xx}) -4.9 -ok- material -new model - define material ID -4-ok- thermal - convection or film coef. -enter HF =35 -ok - close.

Step 4: Modelling

Preprocessor-Modeling -Create -Nodes -in active CS -x,y,z location in CS-0,0,0 (x,y value w.r.t first node)- apply (first node is created)- 0.001,0,0 -apply (second node is created)-0.101,0,0 - apply (third node is created)- 0.102,0,0 -apply (fourth node is created)-0.202,0,0 -apply (fifth node is created)-0.203,0,0 -apply (last or sixth node is created) ok

Create –elements-element attributes-select element type number – LINK34- material number-4- real constant set number -2-Auto numbered – thru nodes – pick 1, 2 (element 1 is created)-ok - element attributes-select element type number – LINK33 - material number-2-real constant set number -1-Auto numbered – thru nodes – pick 2, 3 (element 2 is created)-ok- element attributes-select element type number – LINK33 - material number-3-real constant set number -1-Auto numbered – thru nodes – pick 3, 4 (element 3 is created)-ok - element attributes-select element type number – LINK33 - material number-4-real constant set number -1-Auto numbered – thru nodes – pick 4, 5 (element 4 is created)-ok - element attributes-select element type number – LINK34 - material number-4-real constant set number -2-Auto numbered – thru nodes – pick 5, 6 (element 5 is created)-ok.

Step 5 : Solution:- Analysis Type – New Analysis – pick Steady State – ok.

Loads - Define Loads - Apply –thermal –select temperature –on nodes-pick node 1-apply-select – TEMP- value -820-apply- pick node 6-ok-select –TEMP- value -110-ok

Step 6 -Ansys Main Menu –Solution: Solve -solve current LS -ok (If everything is correct, - solution is done is displayed) –close

Step 7 -Ansys Main Menu -General. Post Processor, Plot results- Contour Plots - Nodal solution – DOF solution.-temp -ok (Temp distribution plot) Plotctrls- Animate – Deformed results – Dof solution – Temperature – ok (for animation) List results -nodal solution -Dof solution -temp -ok (Temperature at all the nodes will be displayed)

PRINT TEMP NODAL SOLUTION PER NODE ***** POST1 NODAL DEGREE OF FREEDOM LISTING *****

```
LOAD STEP= 1 SUBSTEP= 1
TIME= 1.0000 LOAD CASE= 0
NODE TEMP
1 820.00
2 680.31
3 354.36
4 349.47
5 249.69
6 110.00
```

```
MAXIMUM ABSOLUTE VALUES
NODE 1
VALUE 820.00
```

Element Table – Define Table – Add – enter Lab = Heat Flow – Select By Sequence Num - SMISC – SMISC, 1 – ok.

Element Table – List Elem Table – Select Heat Flow – ok. (Heat flow is displayed).

PRINT ELEMENT TABLE ITEMS PER ELEMENT ***** POST1 ELEMENT TABLE LISTING *****

```
STAT CURRENT
ELEM HEATFLOW
1 4889.2
2 4889.2
3 4889.2
4 4889.2
5 4889.2
```

```
MINIMUM VALUES
ELEM 2
VALUE 4889.2
```

```
MAXIMUM VALUES
ELEM 4
VALUE 4889.2
```

Note: Refer appendix on the page No 234

Problem 68: A composite wall consists of three materials as shown. The outer temperature is $T_0 = 20^\circ\text{C}$. Convection heat transfer takes place on the inner surface of the wall with $T_\infty = 800^\circ\text{C}$ and $h = 25 \text{ W/m}^2\text{C}$. Determine the temperature distribution in the wall. $K_1 = 20 \text{ W/m}^\circ\text{C}$, $K_2 = 30 \text{ W/m}^\circ\text{C}$, $K_3 = 50 \text{ W/m}^\circ\text{C}$, $h = 25 \text{ W/m}^2\text{C}$, $T_\infty = 800^\circ\text{C}$

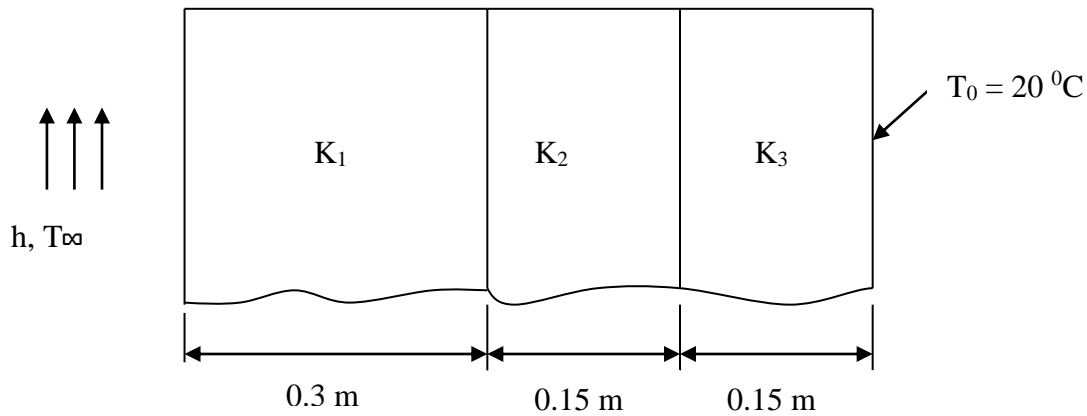

MANUAL APPROACH

Finite Element model:

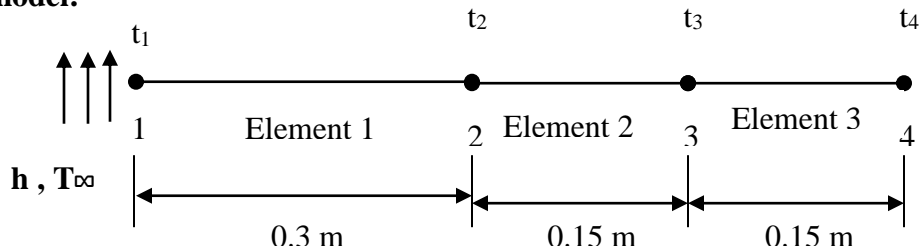

Taking $A = 1 \text{ m}^2$, the element conduction matrices are,
For element 1, we must consider the convection from the free end (left end)

$$[k^1] = \frac{A_1 K_1}{L_1} \begin{bmatrix} 1 & -1 \\ -1 & 1 \end{bmatrix} + hA \begin{bmatrix} 1 & 0 \\ 0 & 0 \end{bmatrix} = \frac{1 \times 20}{0.3} \begin{bmatrix} 1 & -1 \\ -1 & 1 \end{bmatrix} + 25 \times 1 \begin{bmatrix} 1 & 0 \\ 0 & 0 \end{bmatrix}$$

$$= \begin{bmatrix} 1C & 2C \\ 91.67 & -66.67 \\ -66.67 & 66.67 \end{bmatrix} \begin{matrix} 1R \\ 2R \end{matrix}$$

$$[k^2] = \frac{A_2 K_2}{L_2} \begin{bmatrix} 1 & -1 \\ -1 & 1 \end{bmatrix} = \frac{1 \times 30}{0.15} \begin{bmatrix} 1 & -1 \\ -1 & 1 \end{bmatrix} = \begin{bmatrix} 2C & 3C \\ 200 & -200 \\ -200 & 200 \end{bmatrix} \begin{matrix} 2R \\ 3R \end{matrix}$$

$$[k^3] = \frac{A_3 K_3}{L_3} \begin{bmatrix} 1 & -1 \\ -1 & 1 \end{bmatrix} = \frac{1 \times 50}{0.15} \begin{bmatrix} 1 & -1 \\ -1 & 1 \end{bmatrix} = \begin{bmatrix} 333.33 & -333.33 \\ -333.33 & 333.33 \end{bmatrix} \begin{matrix} 3R \\ 4R \end{matrix}$$

And the global structure conduction matrix is,

$$[K] = \begin{bmatrix} 1C & 2C & 3C & 4C \\ 91.67 & -66.67 & 0 & 0 \\ -66.67 & 66.67 + 200 & -200 & 0 \\ 0 & -200 & 200 + 333.33 & -333.33 \\ 0 & 0 & -333.33 & 333.33 \end{bmatrix} \begin{matrix} 1R \\ 2R \\ 3R \\ 4R \end{matrix}$$

$$= \begin{bmatrix} 1C & 2C & 3C & 4C \\ 91.67 & -66.67 & 0 & 0 \\ -66.67 & 266.67 & -200 & 0 \\ 0 & -200 & 533.33 & -333.33 \\ 0 & 0 & -333.33 & 333.33 \end{bmatrix} \begin{matrix} 1R \\ 2R \\ 3R \\ 4R \end{matrix}$$

Now the global equations will be in the form,

$$[K]\{t\} = \{F\}$$

And $\{f_h\}_{\text{end}}$ (left end) is $\{f_h\} = hT_\infty A \begin{Bmatrix} 1 \\ 0 \end{Bmatrix} = \{hT_\infty A\} = \begin{Bmatrix} hT_\infty A \\ 0 \end{Bmatrix} \begin{matrix} 1R \\ 2R \end{matrix}$

Therefore,

$$\begin{bmatrix} 91.67 & -66.67 & 0 & 0 \\ -66.67 & 266.67 & -200 & 0 \\ 0 & -200 & 533.33 & -333.33 \\ 0 & 0 & -333.33 & 333.33 \end{bmatrix} \begin{Bmatrix} t_1 \\ t_2 \\ t_3 \\ t_4 \end{Bmatrix} = \begin{Bmatrix} hT_\infty A \\ 0 \\ 0 \\ F_4 \end{Bmatrix}$$

Since h , T_∞ and t_4 are specified, the above equations are modified as,

$$\begin{bmatrix} 91.67 & -66.67 & 0 & 0 \\ -66.67 & 266.67 & -200 & 0 \\ 0 & -200 & 533.33 & 0 \\ 0 & 0 & 0 & 1 \end{bmatrix} \begin{Bmatrix} t_1 \\ t_2 \\ t_3 \\ t_4 \end{Bmatrix} = \begin{Bmatrix} 20000 \\ 0 \\ 6666.6 \\ 20 \end{Bmatrix}$$

We now obtain three sets of simultaneous equations in which we have three unknown temperatures.

$$91.67t_1 - 66.67t_2 = 20000$$

$$-66.67t_1 + 266.67t_2 - 200t_3 = 0$$

$$-200t_2 + 533.33t_3 = 6666.6$$

On solving, we get $t_1 = 304.76 \text{ }^\circ\text{C}$, $t_2 = 119.05 \text{ }^\circ\text{C}$, $t_3 = 57.14 \text{ }^\circ\text{C}$

The temperatures are,

$$\{t\}^T = [304.76 \text{ }^\circ\text{C} \ 119.05 \text{ }^\circ\text{C} \ 57.14 \text{ }^\circ\text{C} \ 20 \text{ }^\circ\text{C}]$$

COMPARE WITH ANSYS RESULTS

Problem 69: The fin shown in figure is insulated on the perimeter. The left end has a constant temperature of $100 \text{ }^\circ\text{C}$. A positive heat flux $q^* = 5000 \text{ W / m}^2$ acts on the right end. Let $K_{xx} = 6 \text{ W / m}^0\text{C}$ and cross sectional area $A = 0.1 \text{ m}^2$. Determine the temperatures at $\frac{L}{4}, \frac{L}{2}, \frac{3L}{4}$ and L . Where $L = 0.4 \text{ m}$.

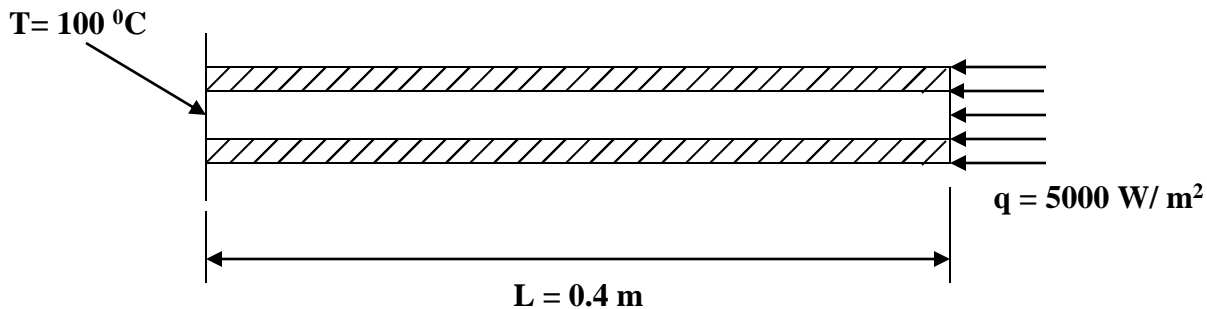

Solution:

<p>Given: $t_1 = 100 \text{ }^\circ\text{C}$, $K_{xx} = 6 \text{ W / m}^0\text{C}$, $A = 0.1 \text{ m}^2$</p> <p>$L_1 = L_2 = L_3 = L_4 = 0.1 \text{ m}$</p>

Finite Element model:

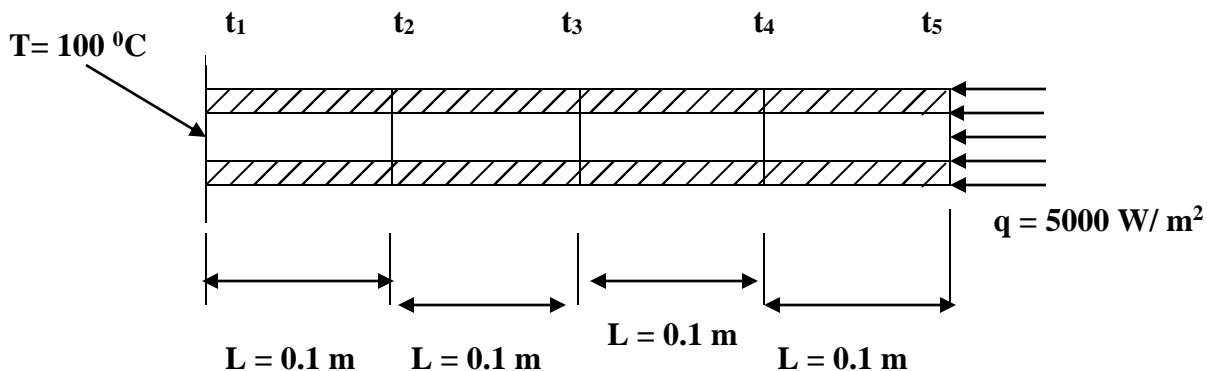

Element conduction matrices are,

$$[k^1] = \frac{A_1 K_1}{L_1} \begin{bmatrix} 1 & -1 \\ -1 & 1 \end{bmatrix} = \frac{0.1 \times 6}{0.1} \begin{bmatrix} 1 & -1 \\ -1 & 1 \end{bmatrix} = \begin{Bmatrix} 1C & 2C \\ \begin{bmatrix} 6 & -6 \\ -6 & 6 \end{bmatrix} 1R \\ 2R \end{Bmatrix} \text{ W/}^\circ\text{C}$$

Similarly we have

$$[k^2] = \begin{Bmatrix} 2C & 3C \\ \begin{bmatrix} 6 & -6 \\ -6 & 6 \end{bmatrix} 2R \\ 3R \end{Bmatrix} \text{ W/}^\circ\text{C}, \quad [k^3] = \begin{Bmatrix} 3C & 4C \\ \begin{bmatrix} 6 & -6 \\ -6 & 6 \end{bmatrix} 3R \\ 4R \end{Bmatrix} \text{ W/}^\circ\text{C} \quad \text{and}$$

$$[k^4] = \begin{Bmatrix} 4C & 5C \\ \begin{bmatrix} 6 & -6 \\ -6 & 6 \end{bmatrix} 4R \\ 5R \end{Bmatrix} \text{ W/}^\circ\text{C}$$

and the global structure conduction matrix is,

$$[K] = \begin{Bmatrix} 1C & 2C & 3C & 4C & 5C \\ \begin{bmatrix} 6 & -6 & 0 & 0 & 0 \\ -6 & 6+6 & -6 & 0 & 0 \\ 0 & -6 & 6+6 & -6 & 0 \\ 0 & 0 & -6 & 6+6 & -6 \\ 0 & 0 & 0 & -6 & 6 \end{bmatrix} 1R \\ 2R \\ 3R \\ 4R \\ 5R \end{Bmatrix} \\ = \begin{Bmatrix} 1C & 2C & 3C & 4C & 5C \\ \begin{bmatrix} 6 & -6 & 0 & 0 & 0 \\ -6 & 12 & -6 & 0 & 0 \\ 0 & -6 & 12 & -6 & 0 \\ 0 & 0 & -6 & 12 & -6 \\ 0 & 0 & 0 & -6 & 6 \end{bmatrix} 1R \\ 2R \\ 3R \\ 4R \\ 5R \end{Bmatrix} \text{ W/}^\circ\text{C}$$

Since a positive heat flux $q^* = 5000 \text{ W/m}^2$ acts on the right end we will have to calculate force term $\{f_q\}$ at end of the element 4.

$$\{f_q\}_{\text{end}} = \int_{\text{Send}} [N]^T q^* dS = \int_{\text{Send}} q^* \begin{Bmatrix} 0 \\ 1 \end{Bmatrix} dS = q^* A \begin{Bmatrix} 1C \\ \begin{Bmatrix} 0 \\ 1 \end{Bmatrix} 4R \\ 5R \end{Bmatrix}$$

Since $N_1 = 0$ and $N_2 = 1$ at right end

Assemble the element equations to obtain the global equations and introduce the boundary conditions.

$$\begin{array}{c} \left\| \begin{array}{ccccc} 1C & 2C & 3C & 4C & 5C \\ \left[\begin{array}{ccccc} 6 & -6 & 0 & 0 & 0 \\ -6 & 12 & -6 & 0 & 0 \\ 0 & -6 & 12 & -6 & 0 \\ 0 & 0 & -6 & 12 & -6 \\ 0 & 0 & 0 & -6 & 6 \end{array} \right] \begin{array}{l} 1R \\ 2R \\ 3R \\ 4R \\ 5R \end{array} \end{array} \right\| \left\| \begin{array}{l} t_1 \\ t_2 \\ t_3 \\ t_4 \\ t_5 \end{array} \right\| = \left\| \begin{array}{c} 1C \\ \left\{ \begin{array}{l} F_1 \\ 0 \\ 0 \\ 0 \\ q^* A \end{array} \right\} \begin{array}{l} 1R \\ 2R \\ 3R \\ 4R \\ 5R \end{array} \right\| \end{array} \right\|$$

Modified equations after imposing boundary conditions,

$$\begin{array}{c} \left\| \begin{array}{ccccc} 1C & 2C & 3C & 4C & 5C \\ \left[\begin{array}{ccccc} 1 & 0 & 0 & 0 & 0 \\ 0 & 12 & -6 & 0 & 0 \\ 0 & -6 & 12 & -6 & 0 \\ 0 & 0 & -6 & 12 & -6 \\ 0 & 0 & 0 & -6 & 6 \end{array} \right] \begin{array}{l} 1R \\ 2R \\ 3R \\ 4R \\ 5R \end{array} \end{array} \right\| \left\| \begin{array}{l} t_1 \\ t_2 \\ t_3 \\ t_4 \\ t_5 \end{array} \right\| = \left\| \begin{array}{c} 1C \\ \left\{ \begin{array}{l} 100 \\ 600 \\ 0 \\ 0 \\ 500 \end{array} \right\} \begin{array}{l} 1R \\ 2R \\ 3R \\ 4R \\ 5R \end{array} \right\| \end{array} \right\|$$

In expanded form we have,

$$12t_2 - 6t_3 = 600 \text{ ----- (1)}$$

$$-6t_2 + 12t_3 - 6t_4 = 0 \text{ ----- (2)}$$

$$-6t_3 + 12t_4 - 6t_5 = 0 \text{ ----- (3)}$$

$$-6t_4 + 6t_5 = 500 \text{ ----- (4)}$$

Solving the above simultaneous equations, we obtain

$$t_1 = 100 \text{ }^\circ\text{C (Given)}, t_2 = 183.3 \text{ }^\circ\text{C}, t_3 = 266.63 \text{ }^\circ\text{C}, t_4 = 349.96 \text{ }^\circ\text{C}, t_5 = 433.297 \text{ }^\circ\text{C}$$

The temperatures are,

$$\{t\}^T = [100 \text{ }^\circ\text{C} \quad 183.3 \text{ }^\circ\text{C} \quad 266.63 \text{ }^\circ\text{C} \quad 349.96 \text{ }^\circ\text{C} \quad 433.297 \text{ }^\circ\text{C}]$$

COMPARE WITH ANSYS RESULTS

Hint: Model the problem using LINK element, Apply Heat flow instead of Heat flux at the right end

Problem 70: ONE DIMENSIONAL FINITE ELEMENT FORMULATION OF FIN

A metallic fin, with thermal conductivity $K_{xx} = 360 \text{ W / m } ^\circ\text{C}$, 0.1 cm thick, and 10 cm long, extends from a plane wall whose temperature is $235 \text{ }^\circ\text{C}$. Determine the temperature distribution and amount of heat transferred from the fin to the air at $20 \text{ }^\circ\text{C}$ with $h = 9 \text{ W / m}^2 \text{ }^\circ\text{C}$. Take the width of fin to be 1 m.

Hint: You may model 2D model (rectangle $L \times t$)

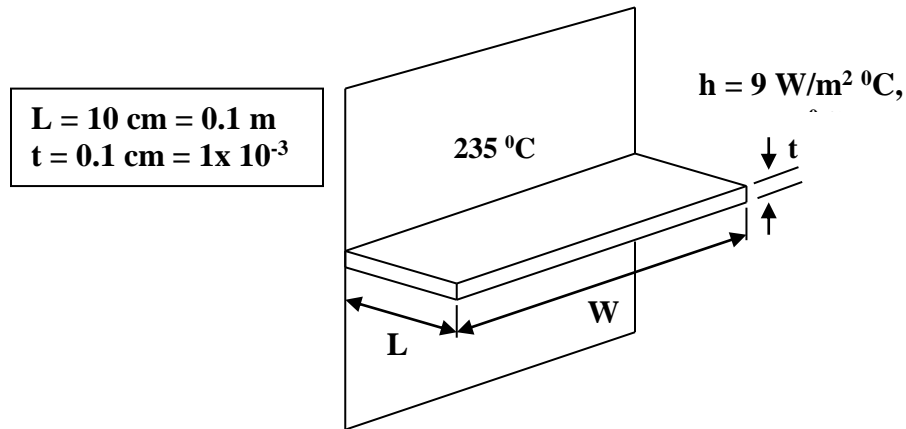

Finite element model:

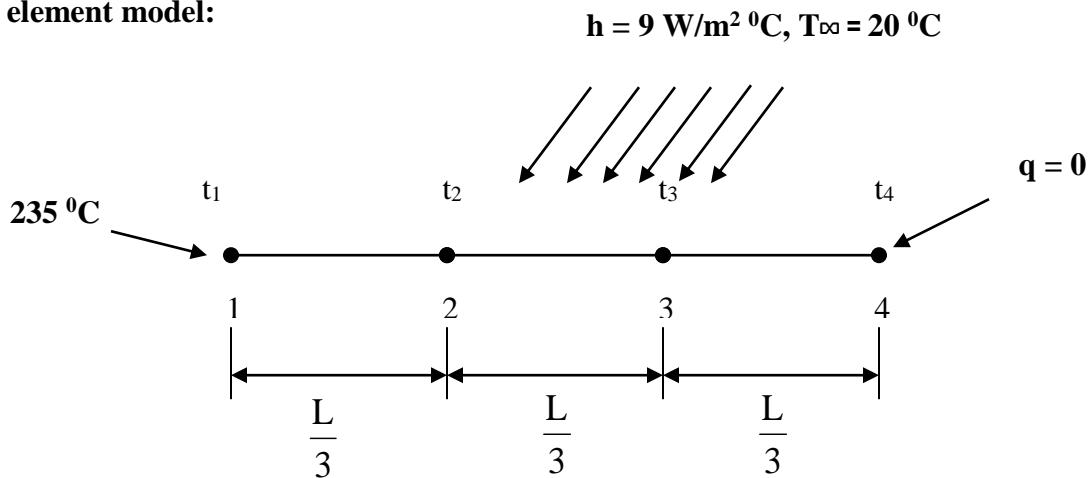

We have the element stiffness (conduction) matrices written as,

$$\begin{aligned}
 [k^1] &= \frac{A_1 K_1}{L_1} \begin{bmatrix} 1 & -1 \\ -1 & 1 \end{bmatrix} + \frac{h P L_1}{6} \begin{bmatrix} 2 & 1 \\ 1 & 2 \end{bmatrix} = \frac{(t \times W) K_1}{L_1} \begin{bmatrix} 1 & -1 \\ -1 & 1 \end{bmatrix} + \frac{h [2t + 2W] L_1}{6} \begin{bmatrix} 2 & 1 \\ 1 & 2 \end{bmatrix} \\
 &= \frac{(1 \times 10^{-3} \times 1) 360}{\frac{1}{30}} \begin{bmatrix} 1 & -1 \\ -1 & 1 \end{bmatrix} + \frac{9 [2 \times 1 \times 10^{-3} + 2 \times 1] \frac{1}{30}}{6} \begin{bmatrix} 2 & 1 \\ 1 & 2 \end{bmatrix} \\
 &= \begin{bmatrix} 1C & 2C \\ \begin{bmatrix} 11.0 & -10.7 \\ -10.7 & 11.0 \end{bmatrix} 1R \\ & 2R \end{bmatrix}
 \end{aligned}$$

Similarly we get,

$$[k^2] = \begin{Bmatrix} 2C & 3C \\ \begin{bmatrix} 11.0 & -10.7 \\ -10.7 & 11.0 \end{bmatrix} \end{Bmatrix} \begin{matrix} 2R \\ 3R \end{matrix}, [k^3] = \begin{Bmatrix} 3C & 4C \\ \begin{bmatrix} 11.0 & -10.7 \\ -10.7 & 11.0 \end{bmatrix} \end{Bmatrix} \begin{matrix} 2R \\ 3R \end{matrix}$$

And the global structure conduction matrix is,

$$[K] = \begin{Bmatrix} 1C & 2C & 3C & 4C \\ \begin{bmatrix} 11.0 & -10.7 & 0 & 0 \\ -10.7 & 11+11 & -10.7 & 0 \\ 0 & -10.7 & 11+11 & -10.7 \\ 0 & 0 & -10.7 & 11 \end{bmatrix} \end{Bmatrix} \begin{matrix} 1R \\ 2R \\ 3R \\ 4R \end{matrix}$$

$$i.e. [K] = \begin{Bmatrix} 1C & 2C & 3C & 4C \\ \begin{bmatrix} 11.0 & -10.7 & 0 & 0 \\ -10.7 & 22 & -10.7 & 0 \\ 0 & -10.7 & 22 & -10.7 \\ 0 & 0 & -10.7 & 11 \end{bmatrix} \end{Bmatrix} \begin{matrix} 1R \\ 2R \\ 3R \\ 4R \end{matrix}$$

The force matrix $\{f_h\}$ is given by,

$$\{f_h^1\} = \frac{hT_\infty PL_1}{2} \begin{Bmatrix} 1 \\ 1 \end{Bmatrix} = \frac{9 \times 20 \times (2 \times 1 \times 10^{-3} + 2 \times 1)}{2} \frac{1}{30} \begin{Bmatrix} 1 \\ 1 \end{Bmatrix} = \begin{Bmatrix} 1C \\ \begin{Bmatrix} 6.006 \\ 6.006 \end{Bmatrix} \end{Bmatrix} \begin{matrix} 1R \\ 2R \end{matrix}$$

$$\{f_h^2\} = \begin{Bmatrix} 1C \\ \begin{Bmatrix} 6.006 \\ 6.006 \end{Bmatrix} \end{Bmatrix} \begin{matrix} 2R \\ 3R \end{matrix} \quad \text{and} \quad \{f_h^3\} = \begin{Bmatrix} 1C \\ \begin{Bmatrix} 6.006 \\ 6.006 \end{Bmatrix} \end{Bmatrix} \begin{matrix} 3R \\ 4R \end{matrix}$$

$$\text{The global equations are, } \begin{bmatrix} 11.0 & -10.7 & 0 & 0 \\ -10.7 & 22 & -10.7 & 0 \\ 0 & -10.7 & 22 & -10.7 \\ 0 & 0 & -10.7 & 11 \end{bmatrix} \begin{Bmatrix} t_1 \\ t_2 \\ t_3 \\ t_4 \end{Bmatrix} = \begin{Bmatrix} 1C \\ \begin{Bmatrix} F_1 + 6.006 \\ 6.006 + 6.006 \\ 6.006 + 6.006 \\ 6.006 \end{Bmatrix} \end{Bmatrix} \begin{matrix} 1R \\ 2R \\ 3R \\ 4R \end{matrix}$$

$$i.e. \begin{bmatrix} 11.0 & -10.7 & 0 & 0 \\ -10.7 & 22 & -10.7 & 0 \\ 0 & -10.7 & 22 & -10.7 \\ 0 & 0 & -10.7 & 11 \end{bmatrix} \begin{Bmatrix} t_1 \\ t_2 \\ t_3 \\ t_4 \end{Bmatrix} = \begin{Bmatrix} 1C \\ \begin{Bmatrix} F_1 + 6.006 \\ 12.012 \\ 12.012 \\ 6.006 \end{Bmatrix} \end{Bmatrix} \begin{matrix} 1R \\ 2R \\ 3R \\ 4R \end{matrix}$$

Applying the boundary conditions, $t_1 = 235^\circ\text{C}$

$$\begin{bmatrix} 1 & 0 & 0 & 0 \\ 0 & 22 & -10.7 & 0 \\ 0 & -10.7 & 22 & -10.7 \\ 0 & 0 & -10.7 & 11 \end{bmatrix} \begin{Bmatrix} t_1 \\ t_2 \\ t_3 \\ t_4 \end{Bmatrix} = \begin{Bmatrix} 1C \\ 235 \\ 12.012 + 2514.5 \\ 12.012 \\ 6.006 \end{Bmatrix} \begin{matrix} 1R \\ 2R \\ 3R \\ 4R \end{matrix}$$

we get three sets of simultaneous equations with three unknowns.

$$\begin{aligned} 22t_2 - 10.7t_3 &= 2526.512 \\ -10.7t_2 + 22t_3 - 10.7t_4 &= 12.012 \\ -10.7t_3 + 11t_4 &= 6.006 \end{aligned}$$

On solving the above equations we get,

$$t_1 = 235 \text{ } ^\circ\text{C (given)}, \quad t_2 = 209.77 \text{ } ^\circ\text{C}, \quad t_3 = 195.17 \text{ } ^\circ\text{C}, \quad t_4 = 190.39 \text{ } ^\circ\text{C}$$

The total heat loss in the fin can be calculated as, $Q_{\text{total}} = \sum_{e=1}^3 Q_{\text{element}}$ And $Q_{\text{element}} = h A_s [t_{\text{avg}} - t_{\infty}]$

Therefore,

$$\begin{aligned} Q_{\text{element } 1} &= h A_s [t_{\text{avg}} - t_{\infty}] = h [2xL_1 x W] \left[\frac{t_1 + t_2}{2} - t_{\infty} \right] \\ &= 9x \left[2x \frac{1}{30} x 1 \right] \left[\frac{235 + 209.77}{2} - 20 \right] = 121.431 \text{ W} \end{aligned}$$

$$Q_{\text{element } 2} = 9x \left[2x \frac{1}{30} x 1 \right] \left[\frac{209.77 + 195.17}{2} - 20 \right] = 109.482 \text{ W}$$

$$Q_{\text{element } 3} = 9x \left[2x \frac{1}{30} x 1 \right] \left[\frac{195.17 + 190.39}{2} - 20 \right] = 103.668 \text{ W}$$

$$Q_{\text{total}} = \sum_{e=1}^3 Q_{\text{element}} = 121.431 + 109.482 + 103.668 = 334.581 \text{ W}$$

COMPARE WITH ANSYS RESULTS

2-D Thermal Analysis

Problem 71. Determine the temperature distribution and the rate of heat flow "q" per metre of the height for a tall chimney whose cross section is shown below. Assume that the inside gas temp is $T_g = 311$ K, the inside convection coefficient is h_i , the surrounding air temp is $T_a = 255$ K and the outside convection coefficient is h_o .

Element type -Thermal solid element -PLANE 55

$K = 1.7307$ W / m K , $h_i = 68.14$ w / m² K, $h_o = 17.04$ w / m² K

Geometric properties-For solving the problem only 1/8th of the model is considered.

(see 3-D view) $a = 4$ m and $b = 2$ m

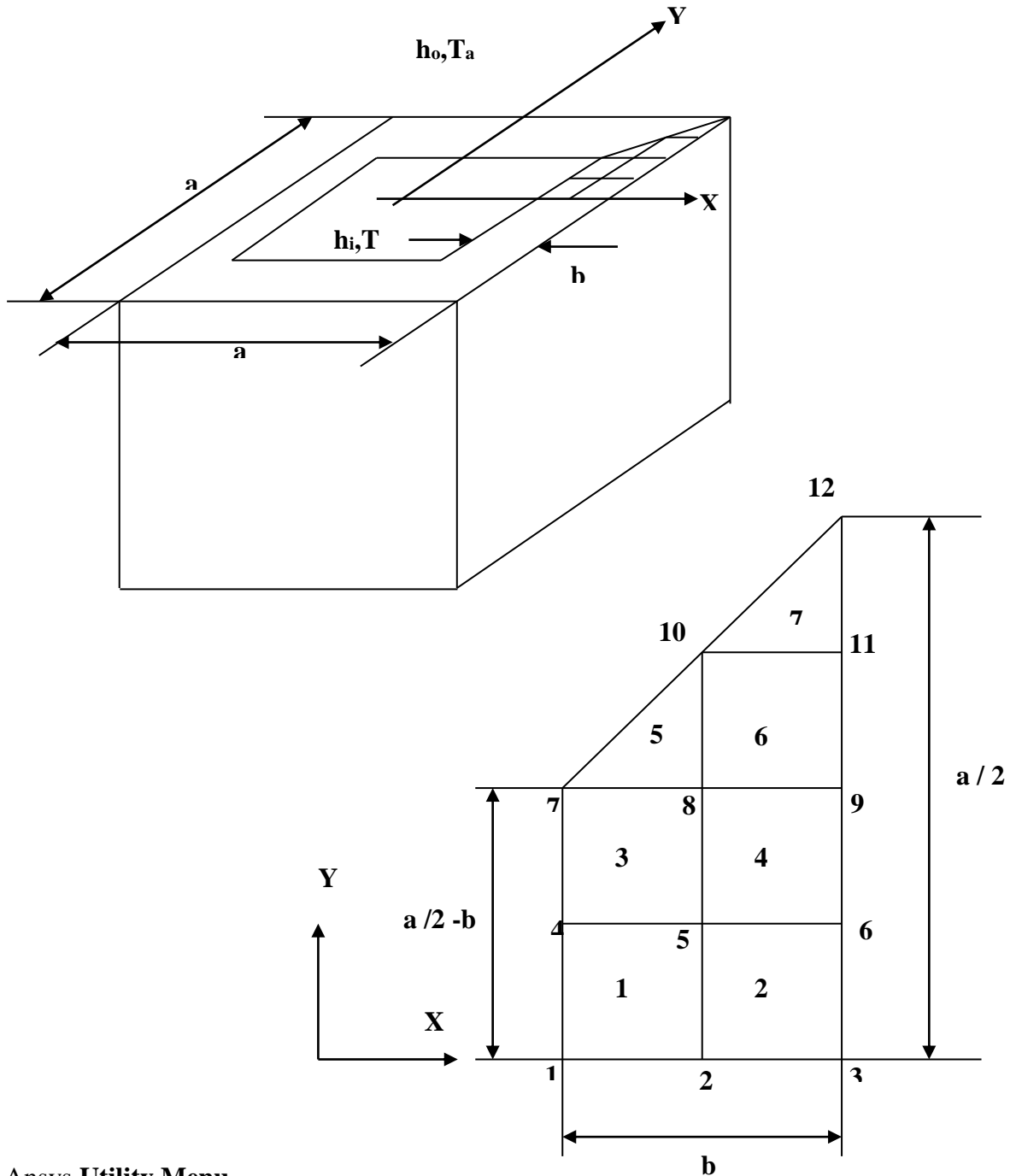

Step 1- Ansys Utility Menu

File -Clear and start new -Do not read file -ok

File -Change job name -Enter new job name -probl -ok

File -Change title -Enter new title -yyy -ok

Step 2 -Ansys Main Menu -Preferences

Select -THERMAL -ok

Step 3 -Preprocessor

Element Type -Add/Edit/Delete -Add- SOLID -QUAD 4 NODE -55- ok -close

Real constants -No real constants

Material properties – Material models – thermal – conductivity –isotropic - conductivity for material - thermal conductivity (K_{xx}) –1.7307 -ok- close

Modeling -Create -Nodes -in active CS -x,y,z location in CS-1,0 (x,y value w.r.t first node)- apply (first node is created)- 1.5,0 -apply (second node is created) -2,0 -apply (third node is created) - 1,0.5 -apply (fourth node is created) -1.5,0.5- apply (fifth node is created)- 2, 0.5 -apply(sixth node is created)- 1,1 -apply (seventh node is created) -1.5,1 - apply (eighth node is created) -2 , 1 - apply (ninth node is created) -1.5 ,1.5- apply (tenth node is created)- 2 , 1.5- apply (eleventh node is created)-2 , 2 -apply (twelfth node is created) –ok

Create –elements-Auto numbered – thru nodes – pick 1, 2,5 & 4 (anticlockwise , element 1)-apply- pick 2, 3, 6 & 5 (element 2) -apply- pick 4 , 5 , 8 & 7 (element 3)- apply-pick 5 , 6 , 9 & 8 (element 4) -apply -pick 7, 8, 10 & 10 (element 5)- apply-pick 8, 9, 11 &10 (element 6:..)- apply - pick 10, 11, 12 & 12 (element 7)-ok (total seven elements ate created through nodes).

Step 5 –Preprocessor

Loads - Define Loads - Apply –thermal -Convection -: on nodes -pick inner surface by box option - apply- Film coefficient (inner) -68.14 - temperature (at inner surface)- 311 (value)-ok

Convection -on nodes -pick outer surface by box option -apply- Film coefficient (outer) -17.04- Temperature (at inner surface) –(255) (value) ~Ok

Step 6 -Ansys Main Menu –Solution

Solve -solve current LS -ok (;If everything is ok, -solution is done is displayed) –close

Step 7 -Ansys Main Menu -General. Post Processor.

Plot results- Contour Plots - Nodal solution –DOF solution.-temp -ok (Temp distribution plot)

List results -nodal solution -Dof solution -temp -ok (Temperature at all the nodes will be displayed)

Plotctrls- Animate – Deformed results – Dof solution – Temperature – ok (for animation)

Results:

```
PRINT TEMP NODAL SOLUTION PER NODE
***** POST1 NODAL DEGREE OF FREEDOM LISTING *****
LOAD STEP=      1  SUBSTEP=      1
TIME=      1.0000  LOAD CASE=      0

   NODE      TEMP
     1      309.69
     2      284.46
     3      259.88
     4      309.62
     5      283.77
     6      259.66
     7      308.27
     8      279.93
     9      258.68
    10      266.74
    11      257.57
    12      255.43

MAXIMUM ABSOLUTE VALUES
NODE      1
VALUE      309.69
```

Problem 72: For the body shown in figure, determine the temperature distribution. The body is insulated along the top and bottom edges, $K_{xx} = K_{yy} = 1.7307 \text{ W/m } ^\circ\text{C}$. No internal heat generation is present.

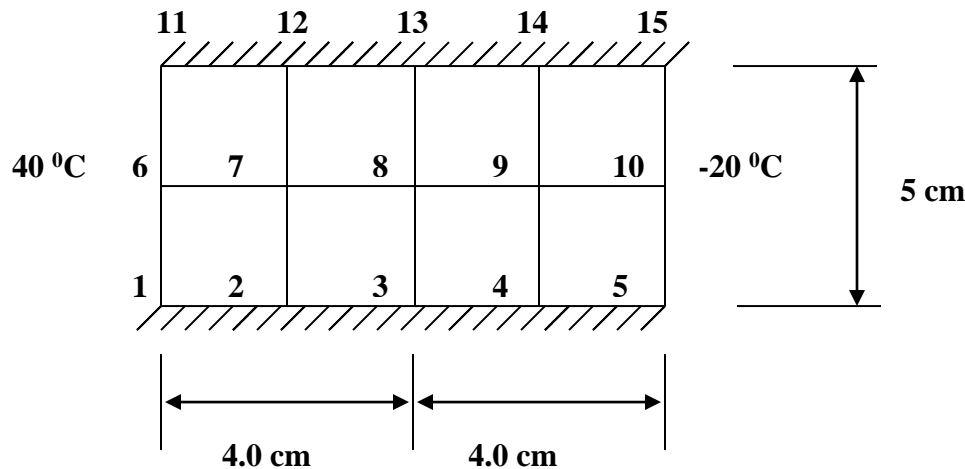

Step 1 -Ansys Main Menu –Preferences : Select -THERMAL -ok

Step 2 Preprocessor: Element Type -Add/Edit/Delete -Add- SOLID-QUAD4 NODE 55- ok -close

Step 3 Real constants -No real constants

Step 4 Material properties – Material models – thermal – conductivity –isotropic - conductivity for material - thermal conductivity (K_{xx}) -1.7307 -ok- close, Modeling -Create -Nodes -in active CS - x,y,z location in CS-0,0 (x,y value w.r.t first node)- apply (first node is created)- 2,0 -apply (second node is created) -4,0 -apply (third node is created) -6,0 -apply (fourth node is created)- 8,0- apply (fifth node is created) - 0, 2.5 -apply(sixth node is created) - 2, 2.5 -apply (seventh node is created) -4, 2.5 - apply (eighth node is created) -6, 2.5 -apply (ninth node is created) - 8, 2.5 - apply (tenth node is created)- 0 , 5- apply (eleventh node is created)- 2, 5-apply (twelfth node is created) 4, 5-apply (thirteenth node is created) 6, 5-apply (fourteenth node is created) 8, 5-apply (fifteenth node is created) –ok, Create –elements-Auto numbered – thru nodes – pick 1, 2,7 & 6 (anticlockwise , element 1)-apply- pick 2, 3, 8 & 7 (element 2) -apply- pick 3 ,4 , 9 & 8 (element 3)- apply-pick 4 ,5 , 10 & 9 (element 4) -apply -pick 6,7, 12 & 11 (element 5)- apply-pick 7, 8, 13 & 12 (element 6:.)- apply -pick 8, 9, 14 & 13 (element 7) pick 9, 10, 15 & 14 (element 8)-ok (total eight elements are created through nodes).

Step 5 –Preprocessor: Loads - Define Loads - Apply –thermal -temperature -: on nodes -pick inner surface by box option - apply- - temperature (at inner surface)-40(value)-apply temperature -on nodes -pick outer surface by box option -apply- Temperature (at inner surface) (-20) (value) ~Ok, Loads - Define Loads - Apply –thermal-heat flux- on nodes- pick top surface by box option - apply- - heat flux – 0 (value)-apply- heat flux- on nodes- pick bottom surface by box option - apply- - heat flux – 0 (value)-apply

Step 6 -Ansys Main Menu –Solution: Solve -solve current LS -ok (;If everything is ok, -solution is done is displayed) –close

Step 7 -Ansys Main Menu -General. Post Processor. Plot results- Contour Plots - Nodal solution – DOF solution.-temp -ok (Temp distribution plot) List results -nodal solution -Dof solution -temp - ok (Temperature at all the nodes will be displayed) Plotctrls- Animate – Deformed results – Dof solution – Temperature – ok (for animation)

Problem 73: Obtain the temperature distribution for the composite cylinder inside which a hot fluid is flowing and the outer surface is exposed to surrounding atmospheric conditions as shown. Assume perfect continuity between the layers. Capture the temperature values at the interface of materials (Use an element size of 0.002m or less).

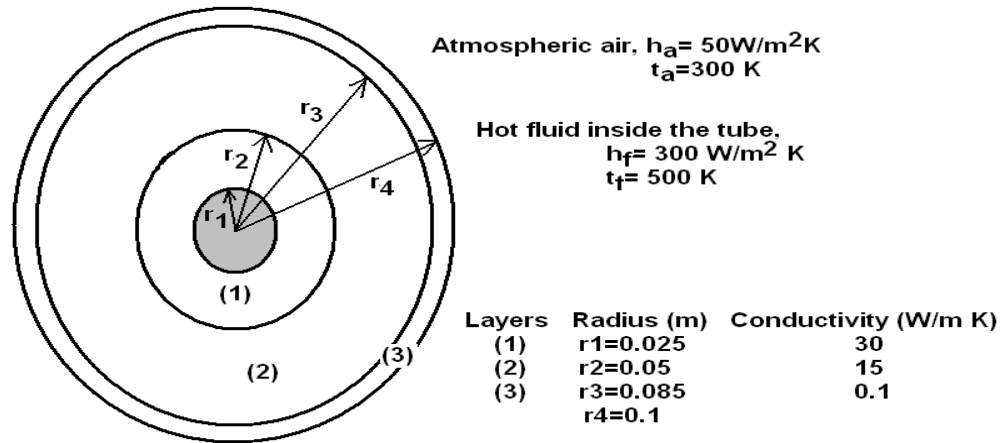

Procedure (One fourth Symmetric model):

- 1.1.1 Preferences > Thermal > OK
- 1.1.2 Element Type > Add/Edit/Delete > Add > Thermal Solid Quad 4node 55 > OK > Close
- 1.1.3 Material Properties > Material Models > Thermal > Conductivity > Isotropic > KXX=30 > OK > Material > New Model > Define Material ID = 2 > OK > Thermal > Conductivity > Isotropic > KXX=15 > OK > Material > New Model > Define Material ID = 3 > OK > Thermal > Conductivity > Isotropic > KXX=0.1 > OK > Close
- 1.1.4 Modeling > create > areas > circle > Partial Annulus > Enter Rad-1= 0.025, Theta-1=0, Rad-2= 0.05, Theta-1=90 > Apply > Enter Rad-1= 0.05, Theta-1=0, Rad-2= 0.085, Theta-1=90 > Apply > Enter Rad-1= 0.085, Theta-1=0, Rad-2= 0.1, Theta-1=90 > OK
- 1.1.5 Modeling > Operate > Booleans > Glue > Areas > Pick all
- 1.1.6 Meshing > Mesh tool > Size Controls Global set > Element edge length = 0.005 > Quad – Mapped – Mesh > Pick all
- 1.1.7 Solution > Define loads > Apply > Thermal > Convection > On lines > Pick the Innermost circle > OK > Film coefficient = 300, Bulk temperature = 500 > OK > Convection > On lines > Pick the Outermost circle > OK > Film coefficient = 50, Bulk temperature = 300 > OK
- 1.1.8 Solve > Current LS > OK
- 1.1.9 General Post Processor > Plot results > Contour Plots > Nodal solution > DOF solution > Temp -ok (Temp distribution plot)
- 1.1.10 Plot > Areas
- 1.1.11 Query results > Subgrid Solu > DOF solution > Temp > OK > Pick the nodes at the material interfaces > Tick Generate 3D annotation “ON” > OK > Note down the interface temperatures.
- 1.1.12 Plot Controls > Annotation > Delete Annotation > Replot

Temperature distribution

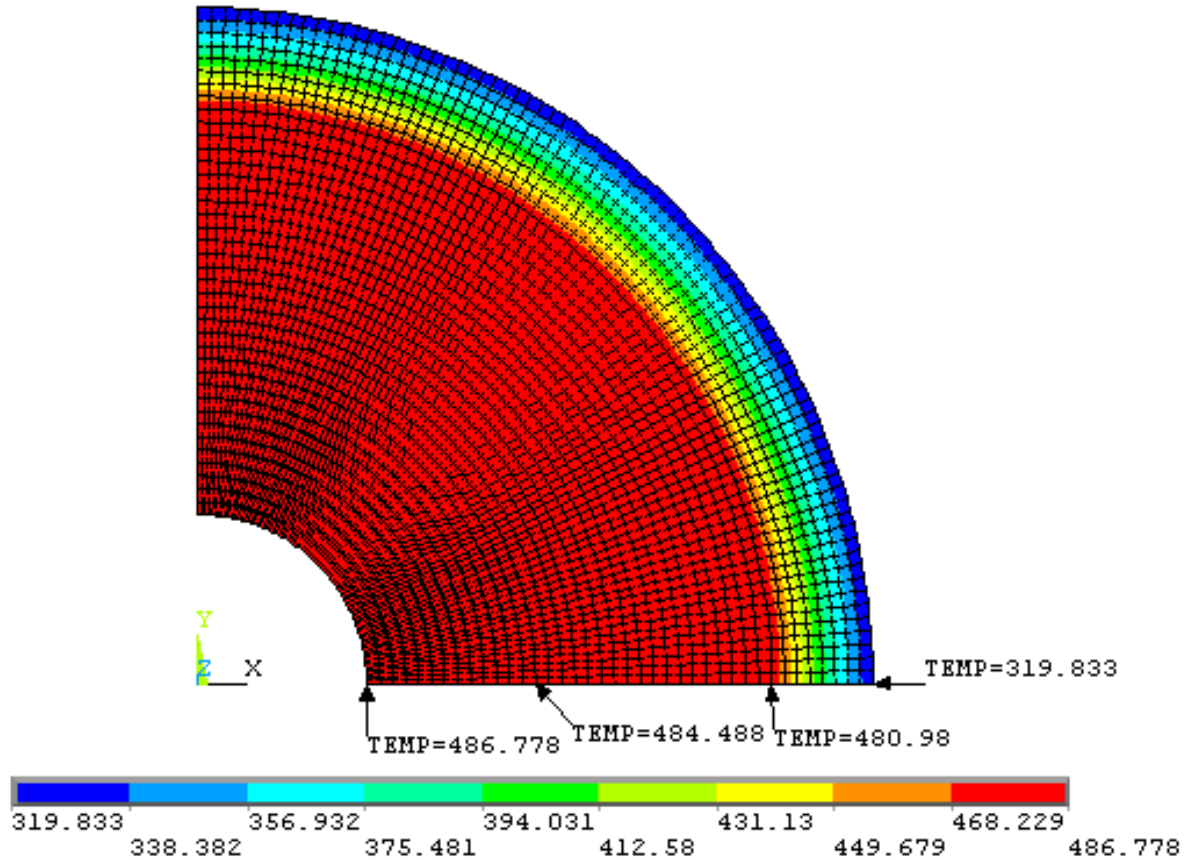

Temperature at the interface of mat 1 & 2 = 484.488K

Temperature at the interface of mat 2 & 3 = 480.98K

Problem 74:

Consider two dimensional heat flow over a L shaped body as shown in figure. The thermal conductivity in both directions is the same $k_x = k_y = 45 \text{ W/m}^\circ \text{C}$. The bottom is maintained at a temperature of $T_o = 110^\circ \text{C}$. Convection heat has taken place on the top where the ambient air temperature is 20°C and the convection heat transfer coefficient is $h = 55 \text{ W/m}^\circ \text{C}$. The right end is insulated. The left end is subjected to heat flux at a uniform rate of $q_o = 8000 \text{ W/m}^2$. Heat is generated in the body at a rate of $Q = 5 \times 10^6 \text{ W/m}^3$. Obtain the temperature distribution.

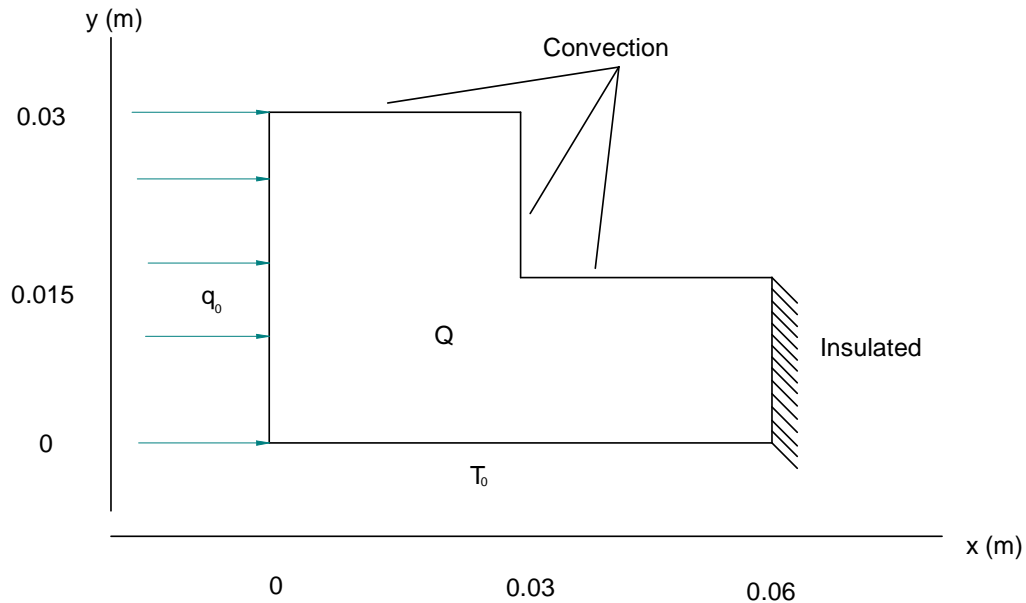

ANSYS solution Procedure:

1. Preferences > Thermal > OK
2. Element Type > Add/Edit/Delete > Add > Thermal Solid Quad 4node 55 > OK > Close
3. Material Properties > Material Models > Thermal > Conductivity > Isotropic > KXX=45 > OK > Close
4. Modeling > create > areas > rectangle > By 2 corners > Width=0.03, Height =0.015, Apply > WP X= 0.03, WP Y=0, Width=0.03, Height =0.015, Apply > WP X= 0, WP Y=0.015, Width=0.03, Height =0.015, OK.
5. Modeling > Operate > Booleans > Glue > Areas > Pick all
6. Meshing > Mesh tool > Size Controls Global set > Element edge length = 0.0075 > Quad – Mapped – Mesh > Pick all
7. Solution > Define loads > Apply > Thermal > Temperature > On lines > select the bottom most lines, OK > VALUE Load TEMP value = 110 > OK
8. Solution > Define loads > Apply > Thermal > Convection > On lines > Pick the lines of Top surface (3 lines) > OK > Film coefficient = 55, Bulk temperature = 20 > OK
9. Solution > Define loads > Apply > Thermal > Heat flux > On lines > pick the lines of left most surface (2 lines)> OK > Heat flux=8000 > OK
10. Solution > Define loads > Apply > Thermal > Heat generation > On areas > pick all > OK > Load HGEN value=5E6 > OK

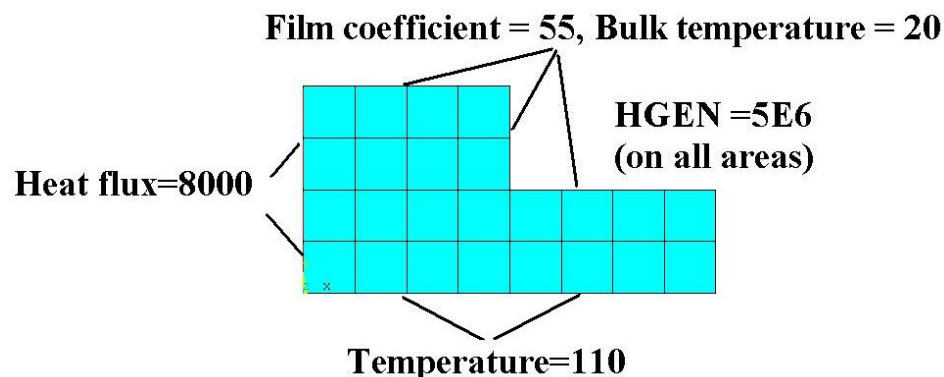

11. Solve > Current LS > OK

12. General Post Processor > Plot results > Contour Plots > Nodal solution > DOF solution > Temp - ok (Temp distribution plot)

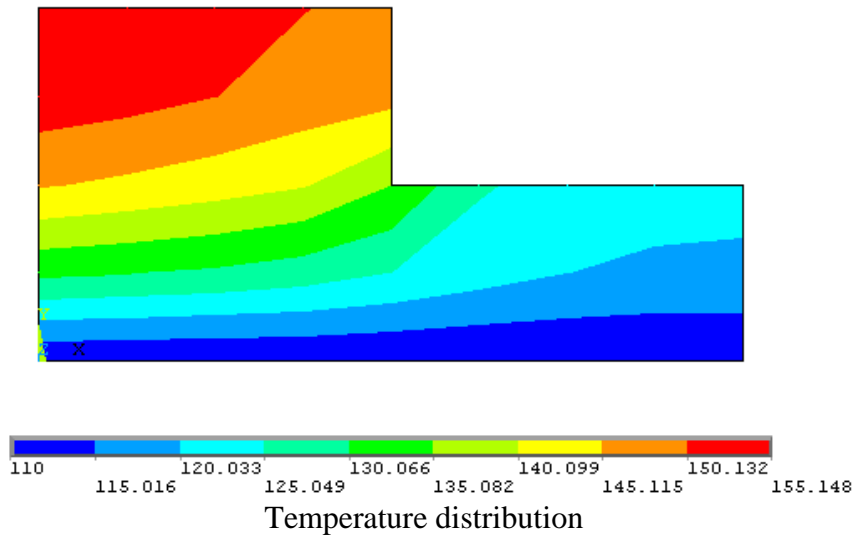

Problem 75:

The cross section of a 20 cm x 20 cm duct made of concrete walls 20 cm thick is shown in figure. The inside surface of the duct is maintained at a temperature of 300°C due to hot gases flowing from a furnace. On the outside the duct is exposed to air with an ambient temperature of 20°C. The heat conduction coefficient of concrete is 1.4 W/m.°C. The average convection heat transfer coefficient on the outside of the duct is 27 W/m²°C.

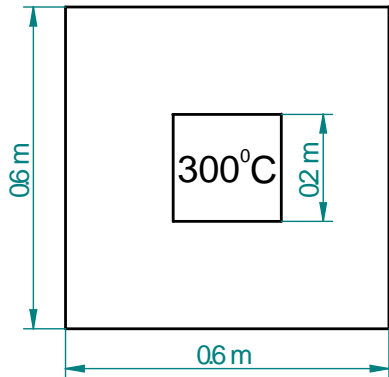

Cross section of a square duct

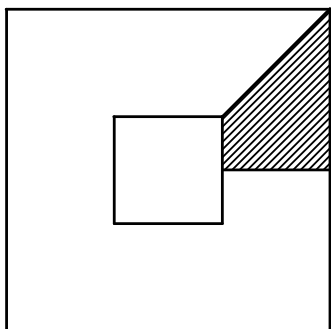

Model of eighth of a square duct

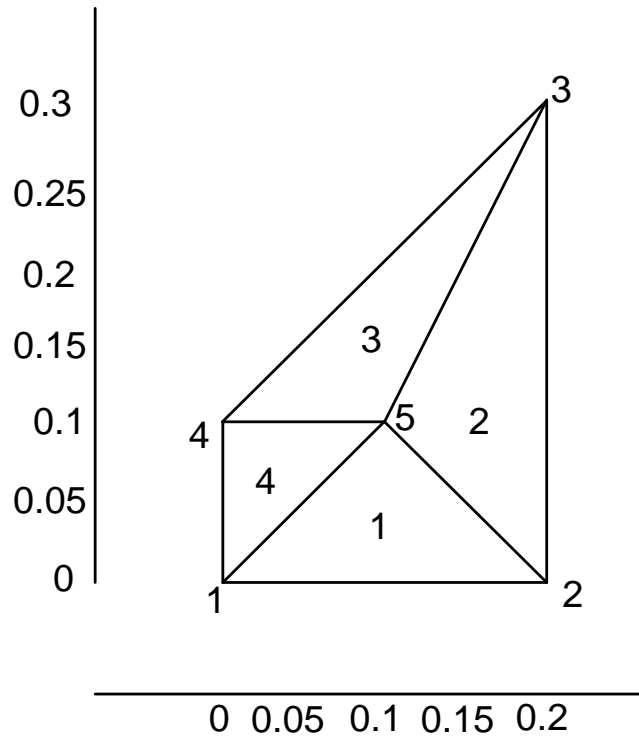

Solution:

FLUID FLOW ANALYSIS:

Computational fluid dynamics (CFD): A fluid is substance that continuously deforms under an applied shear stress regardless of the magnitude of the applied stress. Gas and liquid both are fluid. Fluid mechanics deals with study of fluid, its properties and behavior.

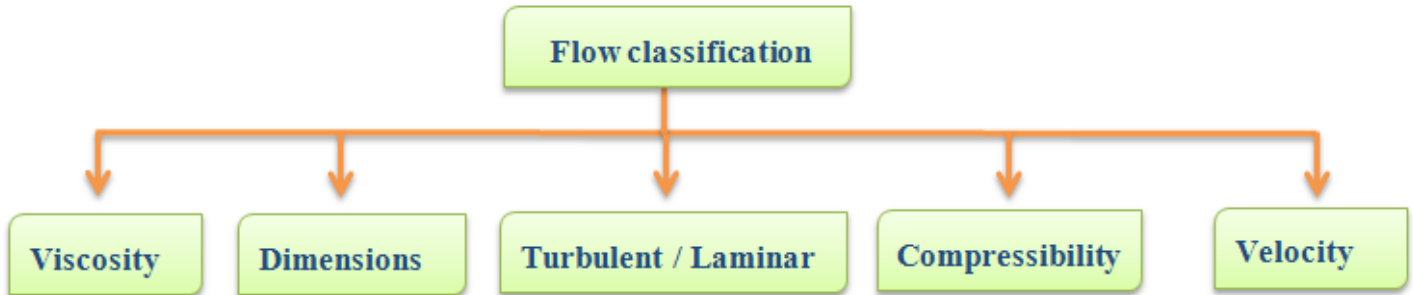
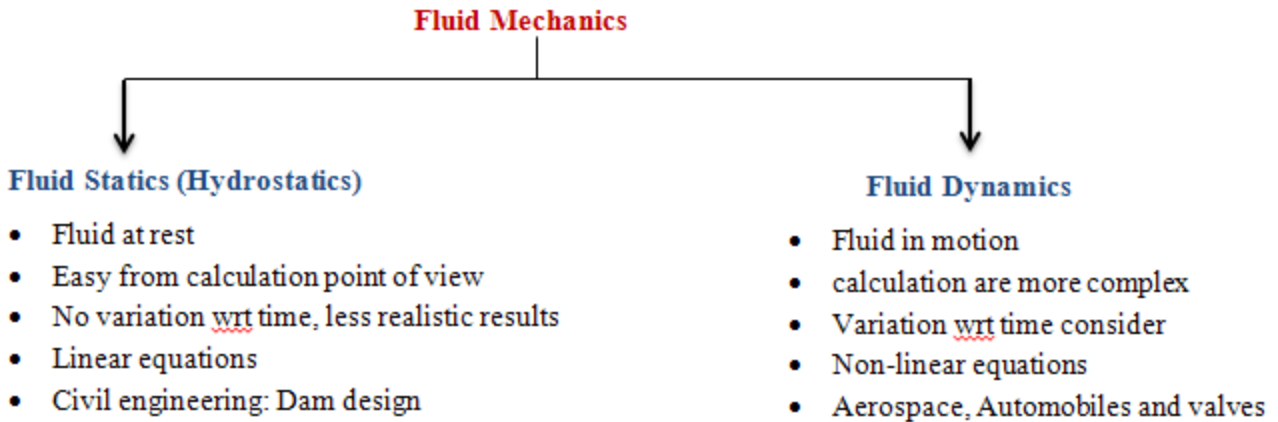

LIST OF COMMONLY USE THERMAL / FLUID ANALYSIS SOFTWARE'S:

Ansys, Sinda, Flowtherm / Radtherm, MSC Nastran, Abaqus, I-deas Nx(TMG, ESC), Icepack

Airpack, Fluent (CFD solver), CFX (CFD solver), STAR-CD (CFD Solver)

Problem 76: Atmospheric air at 20°C flows with a velocity of 5mm/s over a long horizontal cylinder of diameter 25cm. Compute and plot the velocity distribution of air over the cylinder.

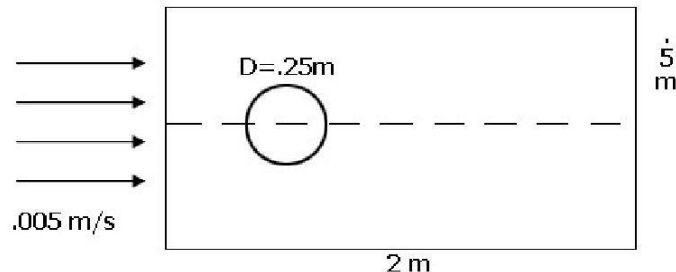

The cylinder is 0.25m in diameter. Considering the symmetry about the horizontal, only the upper half of the cylinder is computed. The results are assumed to be the same below the x axis (axis of symmetry). The arbitrary flow area considered is **2m by 0.5m**.

The velocity of the air at infinite distance from the plate is **5mm/sec (Laminar Flow)**

Step 2 -Ansys Main Menu –Preferences: Select –FLOTTRAN CFD -ok

Step3 –Preprocessor: Element Type-Add/Edit/Delete-Add- FLOTTRANCFD – 2D FLOTTRAN 141 – ok - close

Real constants - No need to Define

Material properties – No Need to Define here as we use standard atmospheric air.

Step 4: Modeling: Preprocessor-Modeling -Create –Area – Rectangle – By 2 corners - enter WP X =0, WP Y=0, Width= 2, Height=0.5 – ok. Create – area – circle - solid circle- enter WP X=0.5, WP Y = 0, Radius=0.125 – ok Modeling – operate – Boolean – Subtract – area - Pick rectangular area – ok – pick circular area – ok., Meshing – Size controls – Manual Size – lines – all lines – enter element edge length=0.02 – ok., Meshing – mesh – areas – free – pick the rectangular area - ok

Step 5 : Solution: Loads - Define Loads - Apply –Fluid/CFD – Velocity – on lines – pick top and left lines – enter $V_x=0.005$, $V_y=0$, $V_z=0$. – ok

Define Loads - Apply –Fluid/CFD – Velocity – on lines – pick bottom and curved circular lines – enter $V_x=0$, $V_y=0$, $V_z=0$. – ok

Define Loads - Apply –Fluid/CFD – pressure dof – on lines – pick right lines – enter $P = 0$. – ok

Solution – Flotran Set Up - Fluid Properties – Enter DENS = AIR SI & VISC = AIR SI – ok and click ok in the following window.

Solution – Flotran Set Up - Execution Ctrl – Global Iterations – enter 1000 – ok.

Solution – **Run Flotran** (problem is being solved, **click ok** when you get ‘Solution is done’ message)

Post Processor: General Postproc - read results - Last Set

To Plot the velocity distribution, General Postproc - plot results – Contour plot - Nodal Solution – DOF Solution- Fluid Velocity – ok

To plot the velocity distribution in vector form,

General Postproc - plot results – Vector plot - Predefined – DOF Solution- Velocity V– ok

To animate the flow of particles

General Postproc – plot results – Defi Trace pt – Pick some nodes (at some location where you want to animate the particle flow) – ok.

Utility Menu - Plot Ctrls – Animate – Particle Flow – DOF Solution – Velocity VX – Ok.

Problem 77: Atmospheric air flows over a flat plate with a velocity of 0.5m/sec. Compute and plot the velocity boundary layer for flow of air over the plate and find the velocity distribution at a distance of 0.5m from the leading edge.

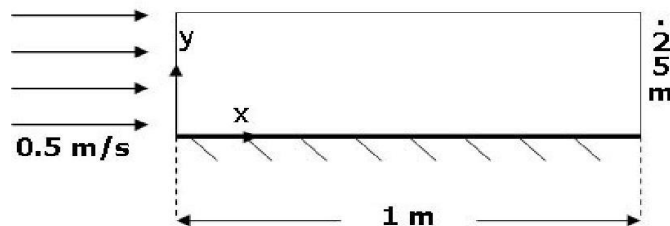

Assume the plate is **1m long**

The arbitrary flow area considered is **1m by 0.25m**

The free stream velocity of the air is **0.5m/s**.

Atmospheric pressure is assumed on all faces except the face where velocity is input into the system

Step 1- Ansys **Utility Menu**

File -Clear and start new -Do not read file -ok

File -Change job name -Enter new job name -problem62 -ok

File -Change title -Enter new title -fluid -ok

Step 2 -Ansys **Main Menu -Preferences**

Select -FLOTRAN CFD -ok

Step 3 -Preprocessor

Element Type -Add/Edit/Delete -Add- FLOTRAN CFD - 2D FLOTRAN 141 - ok - close

Real constants - No need to Define

Material properties - No Need to Define here as we use standard atmospheric air.

Step 4: Modeling

Preprocessor-Modeling -Create -Area - Rectangle - By 2 corners - enter WP X =0, WP Y=0, Width= 1, Height=0.25 - ok.

Meshing - Size controls - Manual Size - lines - picked lines - select top and bottom edges - ok - enter No. of Element Divisions = 50 - apply - Select left and right edges - ok - Enter No. of Element Divisions = 100 and Space Ratio = 10 - ok.

Meshing - Size controls - Manual Size - lines - Flip Bias - Select the left edge only - ok.

Meshing - mesh - areas - free - pick the rectangular area. - ok

Step 5 : Solution

Loads - Define Loads - Apply -Fluid/CFD - Velocity - on lines - pick top and left lines - enter $V_x=0.5, V_y=0, V_z=0$. - ok .

Define Loads - Apply -Fluid/CFD - Velocity - on lines - pick bottom line - enter $V_x=0, V_y=0, V_z=0$. - ok

Define Loads - Apply -Fluid/CFD - pressure dof - on lines - pick right lines - enter $P = 0$ - ok

Solution - Flotran Set Up - Fluid Properties - Enter DENS = AIR SI & VISC = AIR SI - ok and click ok in the following window.

Solution - Flotran Set Up - Execution Ctrl - Global Iterations - enter 400 - ok.

Solution - Run Flotran (problem is being solved, **click ok** when you get 'Solution is done' message)

Post Processor

General Postproc - read results - Last Set

To Plot the velocity distribution,

General Postproc - plot results - Contour plot - Nodal Solution - DOF Solution- Fluid Velocity - ok

To plot the velocity distribution in vector form,

General Postproc - plot results - Vector plot - Predefined - DOF Solution- Velocity V- ok

Click Zoom button on the right side toolbar to show the enlarged view of the vector plot.

To animate the flow of particles

General Postproc – plot results – Defi Trace pt – Pick some nodes (at some location where you want to animate the particle flow) – ok.

Utility Menu - Plot Ctrl – Animate – Particle Flow – DOF Solution – Velocity VX – Ok.

To Show the velocity distribution at a location of 0.5m from the leading edge.

Utility Menu – Select – Entities – Nodes – By Location – X Coordinates – Enter 0.5 – Ok.

Utility Menu – Plot – Nodes

General Postproc - plot results – Vector plot - Predefined – DOF Solution- Velocity V– ok

General Postproc – Path Operations – Define Path – By Nodes – Pick any Two nodes – Ok – Enter Path Name – Ok

General Postproc – Path Operations – Map onto Path – Enter Lab – DOF Solution – VelocityVX – Ok.

General Postproc – Path Operations - plot path item – on graph – velocity – ok.

General Postproc – List Results – Path Item – Velocity - ok

VIVA -VOCE

1. What is Finite element analysis?
2. What are principal stresses and Von Misses stress? Which one would you refer for ductile material and why?
3. What is the sign of von misses stress and absolute principal stress?
4. What is Poisson's ratio? What are the typical values for metal and rubber?
5. What are the basic equations solved during:
 - a) Linear static analysis, b) non-linear analysis c) dynamic analysis, d) crash analysis
 - e) CFD, f) NVH
6. List few commercial FEA softwares.
7. Explain preprocessor, processor/solver and postprocessor as applied to a FE package.
8. Explain any one commercial FEA software.
9. Explain a typical commercial finite element package with respect to the following points
 - i. Its structure
 - ii. Typical elements available
 - iii. Field of application
10. Write briefly about library of elements available in FEM packages.
11. Illustrate the basic idea underlying FEM with an example of determining area of a circle using triangular elements
12. Compare the continuum method with the finite element method, clearly bringing out the differences, advantages and disadvantages
13. Compare features of finite element method with finite difference method.
14. Classify method of structural analysis.
15. List important types of structural analysis.
16. Explain static and dynamic analysis.
17. Explain types of dynamic analysis.
18. What are interpolation functions? Explain why polynomial types are widely used.
19. Write linear interpolation functions for 1D, 2D and 3D cases.
20. Write quadratic interpolation functions for 1D, 2D and 3D cases.
21. Write cubic interpolation functions for 1D, 2D and 3D cases.
22. Explain Simplex, Complex and multiplex elements.
23. Discuss the considerations to be taken into account while choosing/Selecting the order of interpolation function.
24. Explain Convergence criteria.
25. Explain Pascal Triangle and Spatial Isotropy.
26. Explain the steps involved in F.E.A?
27. Explain with examples of bar and beam, Essential and Non essential boundary conditions.
28. Write expression for potential energy in a body under 3D state of stress and justify.
29. State principle of Minimum Potential Energy.
30. Explain Rayleigh-Ritz method applied to continuum. What are its disadvantages?
31. Explain Galarkin method applied to continuum.
32. Explain steps involved in Galarkin method.
33. Explain i) linear algebraic equations ii) homogenous and non homogeneous equations.
34. Classify the methods of solution to linear algebraic equations.
35. Write sketches of important types of Elements indicating its degree of freedom.
36. What is Degree of freedom (DOF), draw following elements with their DOF:
 - a) Quad 4
 - b) Tetra 10
 - c) Beam element

37. What is isoparametric element?
38. Write the Stiffness Matrix $[k]$ for 2 noded 1-D elements.
39. Explain with example importance of node numbering and its effect on band width of Stiffness matrix.
40. Discuss Properties of stiffness matrix.
41. Explain the use of local coordinates and global coordinates in finite element method.
42. Explain C_0 , C_1 , C_2 and C_r continuity.
43. Explain H convergence, P Convergence and R convergence.
44. Explain higher order elements.
45. What is a higher order element? Justify the need for higher order element.
46. Write the shape functions for Quadratic and Cubic one dimensional element in Global coordinates.
47. Sketch Quadratic and cubic two dimensional triangular elements.
48. Sketch Quadratic and cubic two dimensional quadrilateral elements.
49. Describe two dimensional element – triangular, quadrilateral in shape and linear, quadratic and cubic in order using neat sketches, clearly identify the nodes, degrees of freedom and polynomial basis for each element.
50. What is Jacobian?
51. Distinguish between Lagrange and Serendipity family element.
52. Explain Iso-, Sub- and Super-parametric elements.
53. Explain Simplex, complex and multiplex elements.
54. Explain LST element.
55. Explain CST element.
56. Explain Serendipity elements.
57. Write the following for 2 noded bar element. Shape functions, strain displacement matrix and Element stiffness matrix. Stress recovery matrix.
58. Explain consistent load vector due to body force and surface traction for a 2 noded bar element.
59. Write element stiffness matrix for a truss element in 2D global coordinate system.
60. What are Hermitian functions?
61. Write the stiffness matrix for a 2 noded beam element.
62. What do you mean by plane stress and plane strain problem? Give examples and write stiffness matrices for the same.
63. Explain why a three noded triangular element is called CST element.
64. Sketch four noded quadrilateral element indicating its DOF.
65. Write element matrices for one dimensional steady state heat conduction.
66. Write typical element equation for 1D element used in steady state conduction application. Explain different terms used.
67. Explain Elimination and penalty approaches of handling boundary conditions.
68. Explain Harmonic analysis.
69. What is natural frequency? How many natural frequencies can any object have?
70. Is it possible to solve a structural analysis problem (say plate with hole subjected to tensile load) via FEM, BEM, FVM and FDM all?
71. Explain modal analysis.
72. What are Eigen value and Eigen vector? Explain its importance in structural analysis.
73. What is mass moment of inertia & area moment of inertia?

Appendix

Solution format-Plate with a hole

Step1: Name and sketch the element to be used showing its degree of freedom

Step2 : Sketch of the Plate with dimensions and load.

Step3: Sketch the quarter model

Show the origin , XY axes and key points.

List the co-ordinates of critical key point	x	y
1		
2		

Step4: On the quarter model , show the

- a) Displacement boundary conditions b) Force /pressure boundary conditions. And also Lkey.
c) Critical point

Step5 : Specify the mesh type (Free meshing or Mapped Meshing):Important details

Step 6. Convergence studies

Sl.No	Edge Length	No of Nodes	No of Elements	Critical Node number	V.M.S at critical point
1					
2					
3					

Step 7:Plot Graph of VM stress versus number of elements.

Step 8: Conclusions.

Solution format-Beam modal analysis

Step1: Name and sketch the element to be used showing its degree of freedom

Step2 : Sketch of the given beam. Show the origin and XYZ axes.

Step3: List the co-ordinates of key point / nodes in a table (specify units)

Keypoint/node number	coordinates		
	x	y	Z
1			
2			
3			

Step4: Tabulate real constants (based on Beam std. sections) and material properties

Sl.no	Element number	Area and relevant moment of inertia	Material no. and value of E with units
1			
2			

Step 5: Sketch the figure showing node numbers and element numbers

Step 6: List Displacement boundary conditions

Displacement boundary conditions to incorporated						
Node	U_x	U_y	U_z	ROTx	ROTy	ROTz

Step7: Specify the type of algorithm, number of modes to extract.

Solution

Step8: List model solution and Compare with theoretical value

Mode	Natural Frequencies in Hz		Percent Error
	Theory	ANSYS	
1			
2			

Step9: Plot the Mode shapes

Step10: Conclusion

Solution format-thermal analysis

Step1: Name and sketch the element to be used showing its degree of freedom

Step2 : Sketch of the given model. Show the origin and XY axes.

Step3: List the co-ordinates of key point / nodes in a table (specify units)

Keypoint/node number	coordinates		
	x	y	Z
1			
2			

Step4: Tabulate real constants and material properties

Sl.no	Element number	Real constant set no. and value with units	Material no. and value of K with units
1			
2			

Step 5: Sketch the figure showing node numbers and element numbers

Step 6: List boundary condition

Node	T ⁰ C

Solution

Step7: Nodal Temperature

Node	Temperature

Step8: Heat flux/ flow

ETABLE Item and sequence number for Heat flow

Sl.no	Element number	Heat flow with units
1		
2		

**Also plot graph TEMP v/s POSITION

Step9: Conclusion

Acknowledgment

The department of Mechanical Engineering is deeply indebted and wish to express sincere thanks to all the faculties who have contributed in the preparation of this manual.